



USER MANUAL – EN

**IN SP1112 Springless Trampoline with Handlebar Spartan
Hexagon 136 cm**



CONTENTS

- SAFETY INSTRUCTIONS..... 3
- PROPER USE 4
- PARTS LIST 5
- ASSEMBLY 6
 - How to attach loops 9
- ENVIRONMENT PROTECTION 11
- TERMS AND CONDITIONS OF WARRANTY, WARRANTY CLAIMS..... 11

SAFETY INSTRUCTIONS

- The maximum weight limit is 100 kg. This limit cannot be exceeded.
- Read the manual before first use and keep it for future reference.
- Only use the trampoline in accordance with this manual. Any other use may result in injury, or even death.
- Do not modify the product in any way. Only maintain the product according to the instructions in this manual.
- Assembly must be done by an adult.
- The trampoline is not suitable for children. Keep children and pets away from the trampoline. You must be over 14 years to use the trampoline. We recommend to use it under professional supervision for higher safety and better fitness results.
- Only one person can use the trampoline at a time.
- Do not place other objects on or under the trampoline. Do not place any objects in its vicinity either. Do not enter the space under the trampoline.
- People with impaired senses or motor movements cannot use the trampoline. If in doubt, consult the suitability of the exercises with your physician.
- Do warm-up exercises before each use.
- Make sure the space you exercise in is well-ventilated.
- Wear suitable and comfortable clothes. Make sure the clothes are not too loose, they might get caught in the trampoline. Always wear shoes. **WARNING:** Do not use shoes with hard soles or sharp edges. You may damage the trampoline or contribute to its wear.
- Consult a physician before starting an exercise program, especially if you have heart problems, blood circulation problems, orthopedic problems or haven't been exercising for a while. Pregnant women should also consult exercising on the trampoline with a doctor.
- Exercise slowly and maintain an adequate pace. Too much effort may cause serious health complications. Make regular pauses.
- Do not use the trampoline directly after a meal. Do not exercise while under the influence of alcohol or drugs. Use the trampoline only if you feel well. If you start to feel unwell during the exercise or have any other problems (including uneven breathing or irregular heart beat), stop exercising immediately. Consult further exercising with a physician
- Place the trampoline on a firm, flat and clean surface. If you have a wooden floor or other less durable surface, place the trampoline on a protective mat.
- The trampoline can be assembled and used only indoors. Protect the trampoline from outside forces.
- Be careful not to pinch your fingers while installing the elastic side loops. The loops are there to attach the jumping mat to the frame. It is important to fasten them correctly and regularly check their flexibility. Be careful while tightening them and use the tools provided. The trampoline should be assembled by two people.
- Do not use the trampoline in spaces with low ceilings, where there is a chance of a head impact. Keep at least 2 meters of free space around the trampoline. It is important to keep a free space around the trampoline in case you need to get off the trampoline safely during an emergency. Do not place the trampoline on concrete, tarmac or other hard surfaces.
- Do not place the product near heat sources (fires, fireplaces, ovens, etc.).
- Should there appear sharp edges on the trampoline, do not use it.
- Do not use the trampoline if it's wet.

- The trampoline should not be exposed to direct sunlight, freezing temperatures, high moisture or rapid changes in temperature. It could become irreparably damaged.

PROPER USE

- Before every use, make sure all parts and screws are in place and sufficiently tightened. Regularly check all components for wear or damage. Do not use the trampoline in such cases. Worn or damaged components must be replaced immediately.
- Do not modify the trampoline by yourselves. Contact a qualified customer service. Unauthorized modifications are not covered by the warranty.
- Make sure the frame is stable and that all 32 flexible loops are fastened correctly. They must be stretched tight. Before every use, make sure the handlebars are inserted correctly and adjusted to the correct height.
- The handlebars help you keep balance. Do not lean on them with your full weight, you could overturn the trampoline. Make sure your clothes or hair do not get caught on the handlebars.
- The handlebar height can be adjusted according to the height of the user. Do not forget to secure the new position with the safety knob.
- Do not place any objects onto the trampoline. Do not attach unauthorized accessories to the trampoline.
- The trampoline is suitable only for light fitness exercises (walking, light jumps, slants, etc.). Do not, under any circumstances, try to do back flips or jump off the trampoline. You could fall on your head or neck and sustain a fatal injury.
- Do not jump onto the trampoline from higher ground and don't try to jump off it. Be careful while using it. Keep your hands and pockets empty while jumping.
- Do not jump while eating or drinking. Make sure you stay hydrated while exercising.
- Familiarize yourself with the product first. Only then attempt more difficult exercises. Always keep the jumps under control and do not overexert yourselves.
- Only jump in the middle of the mat. Do not step on the edges, including the elastic loops.
- Transport it carefully and don't hurt your back. Ask some other adult person for help, if necessary.

PARTS LIST

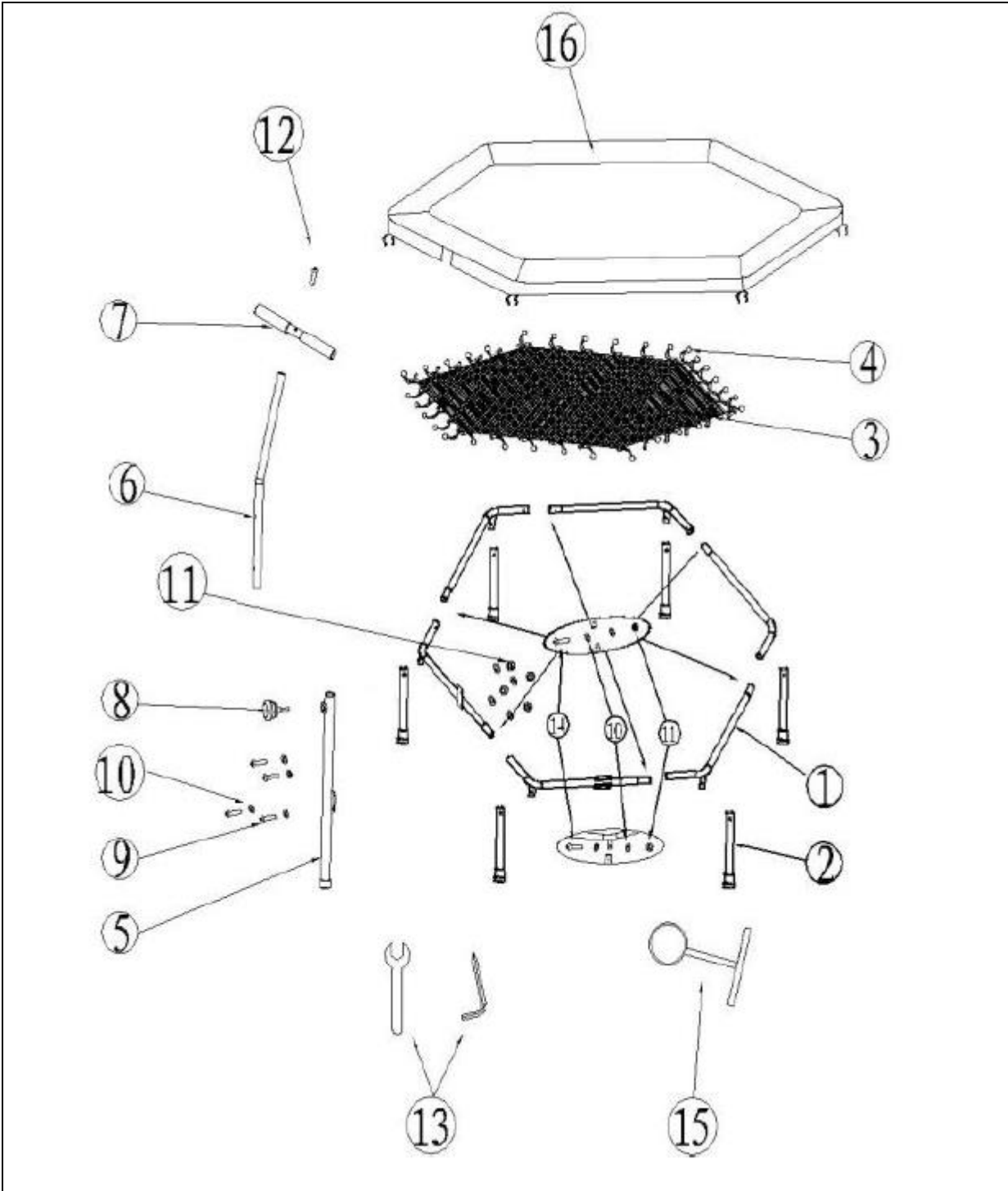

No.	Name	Qty.
1	Frame	6
2	Feet	6
3	Jumping mat	1
4	Loop	42
5	Bottom frame holder	1
6	Top frame holder	1

7	Handles	1
8	Hand knob	1
9	Bolt M6x15	4
10	Small washer	32
11	Nut	16
12	Bolt	1
13	Wrench	2
14	Bolt M6x35	12
15	Tool to attach loops	1
16	Loop cover	1

ASSEMBLY

Step 1

Connect the frame (1) with bolts (14), washers (10) and nuts (11), see. picture.

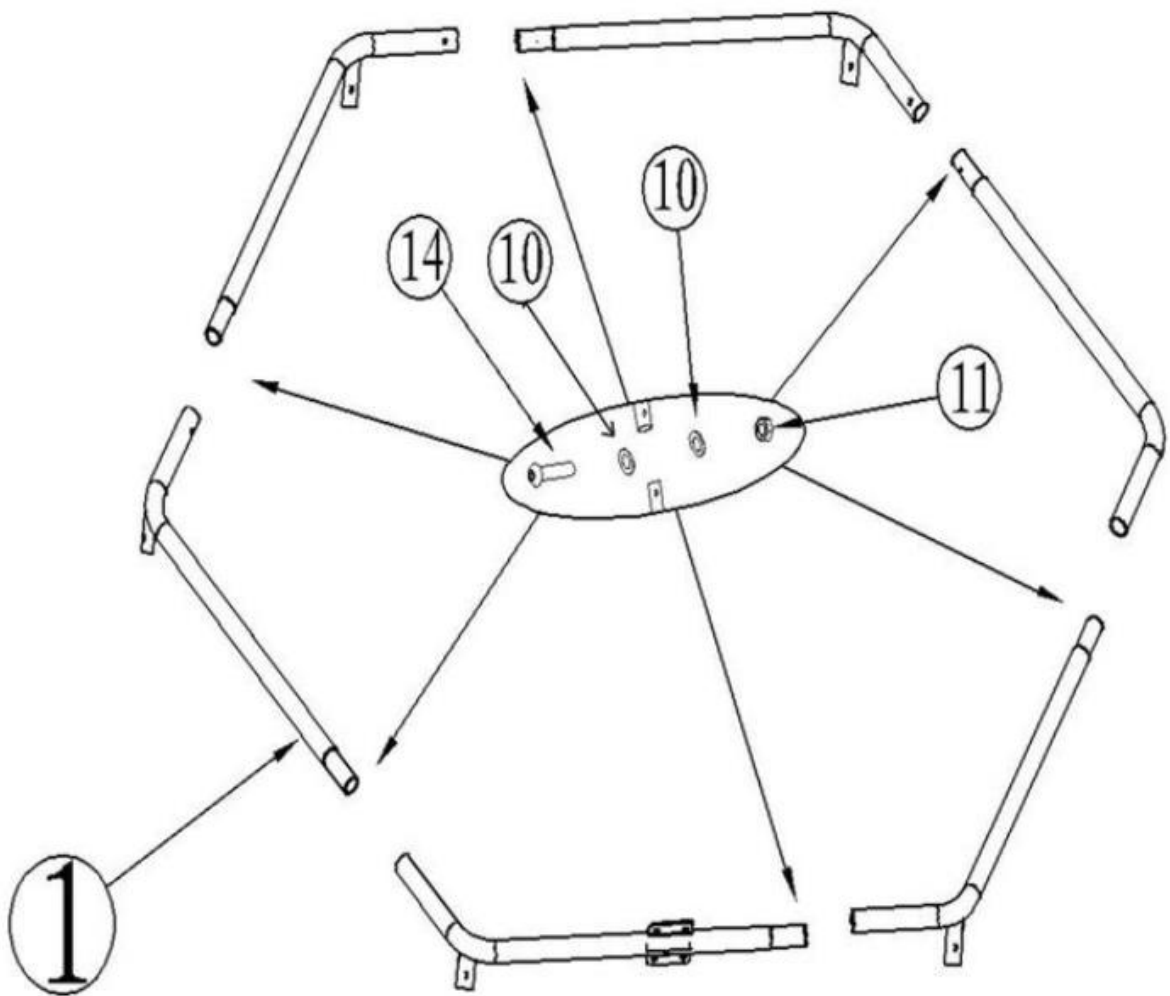

Step 2

Remove the covers from the legs (2) and attach the legs (2) to the frame (1) with bolts (14), washers (10) and nuts (11).

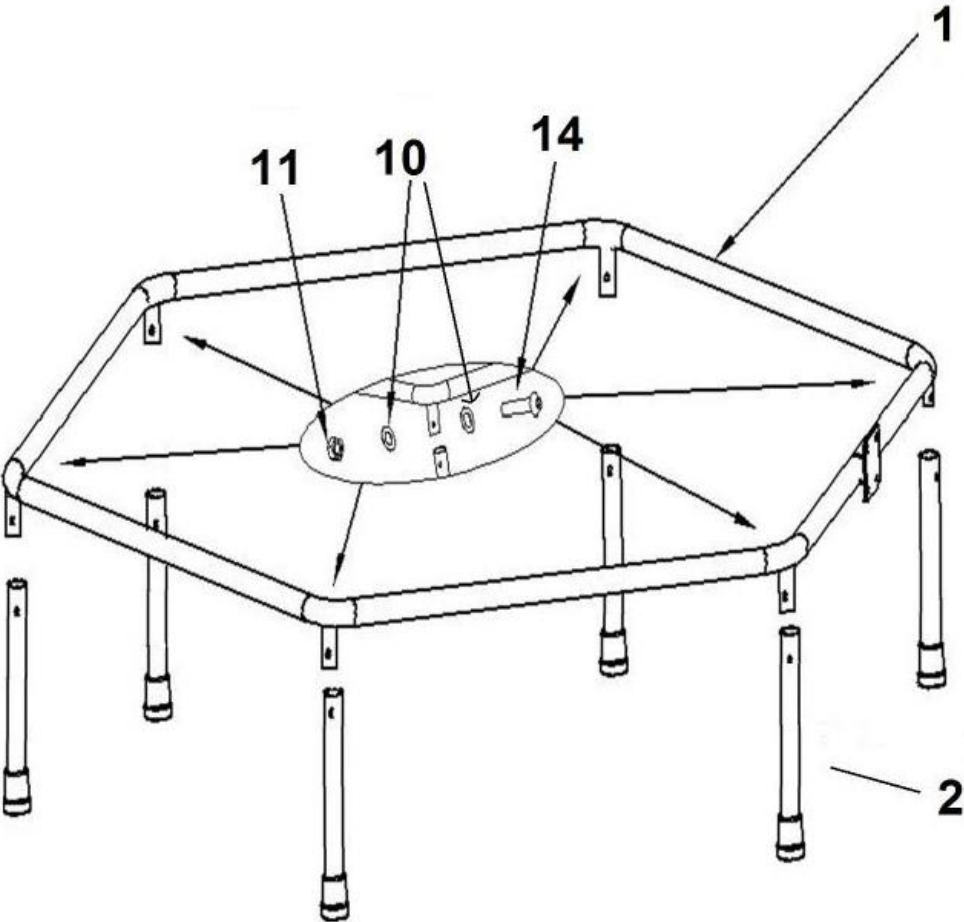

Step 3

Attach the loops (4) to the jumping mat (3).

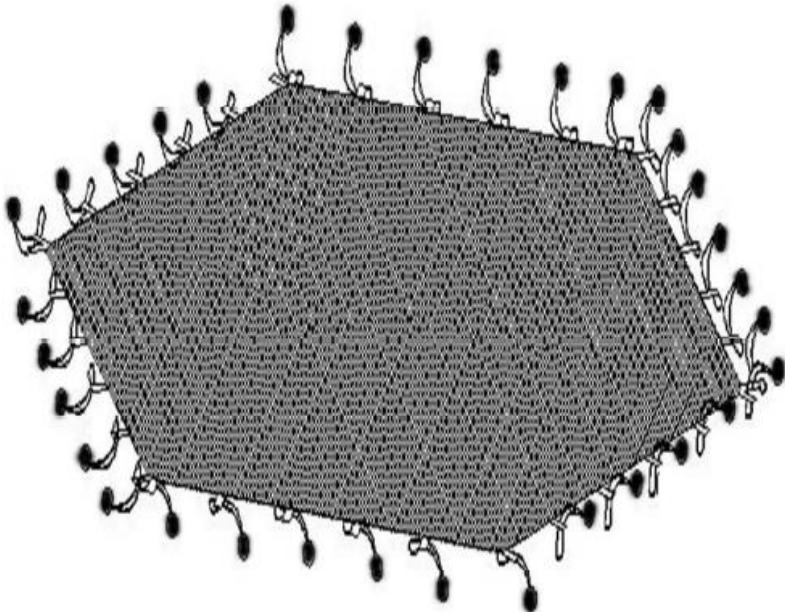

Step 4

Attach the jumping mat (3) to the frame (1). First attach the two loops (4) to the opposite corners and then always attach the loops to each other.

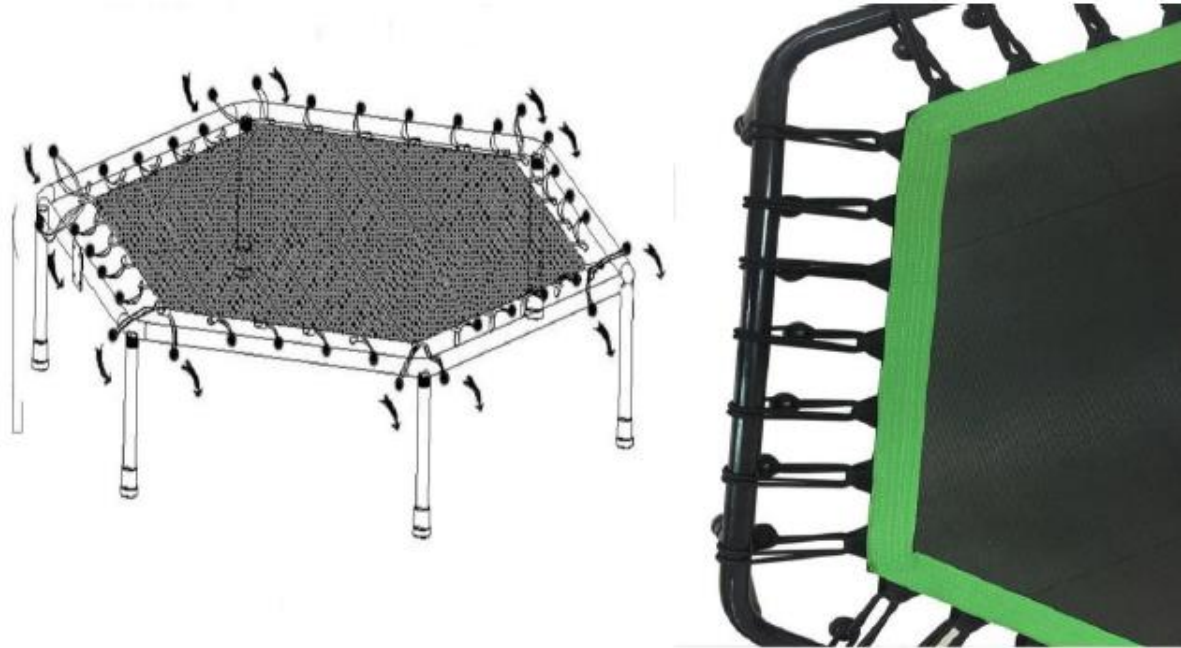

How to attach loops



Step 1

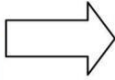

Step 2



Step 3

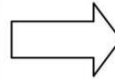

Step 4



Step 5

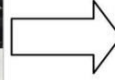

Step 6



Step 7



Step 8

Step 5

Attach the lower part of the handle (5) to the frame (1) with bolts (9), washers (10) and nuts (11).

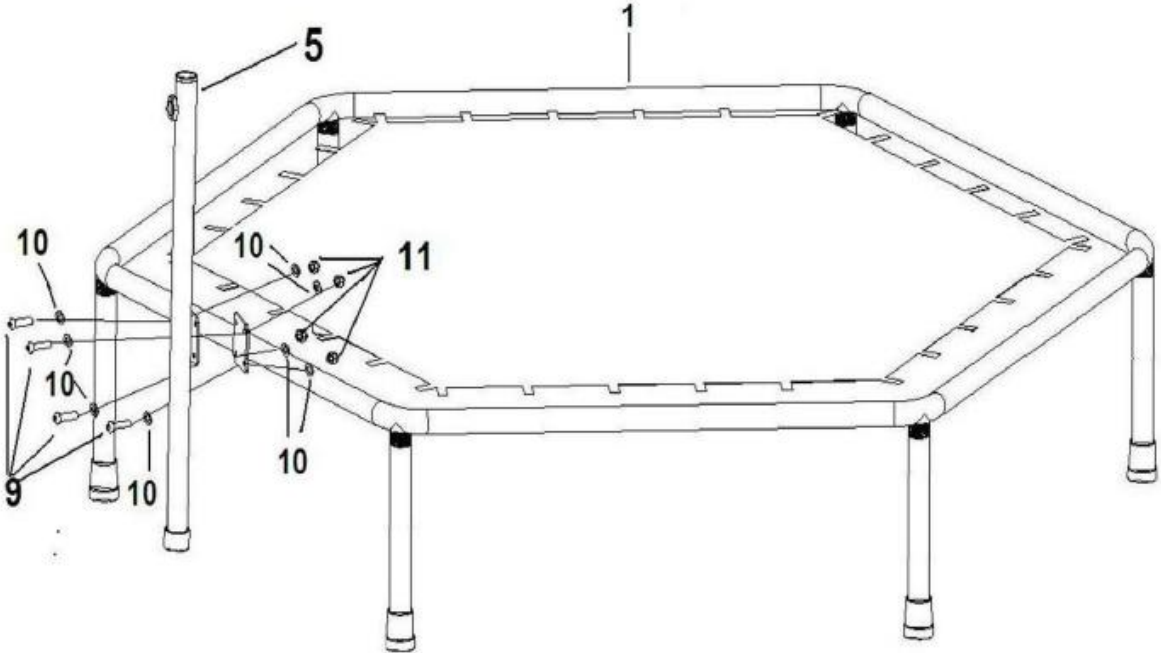

Step 6

Attach the upper part of the handle (6) to the lower part of the handle (5) with hand knob (8).

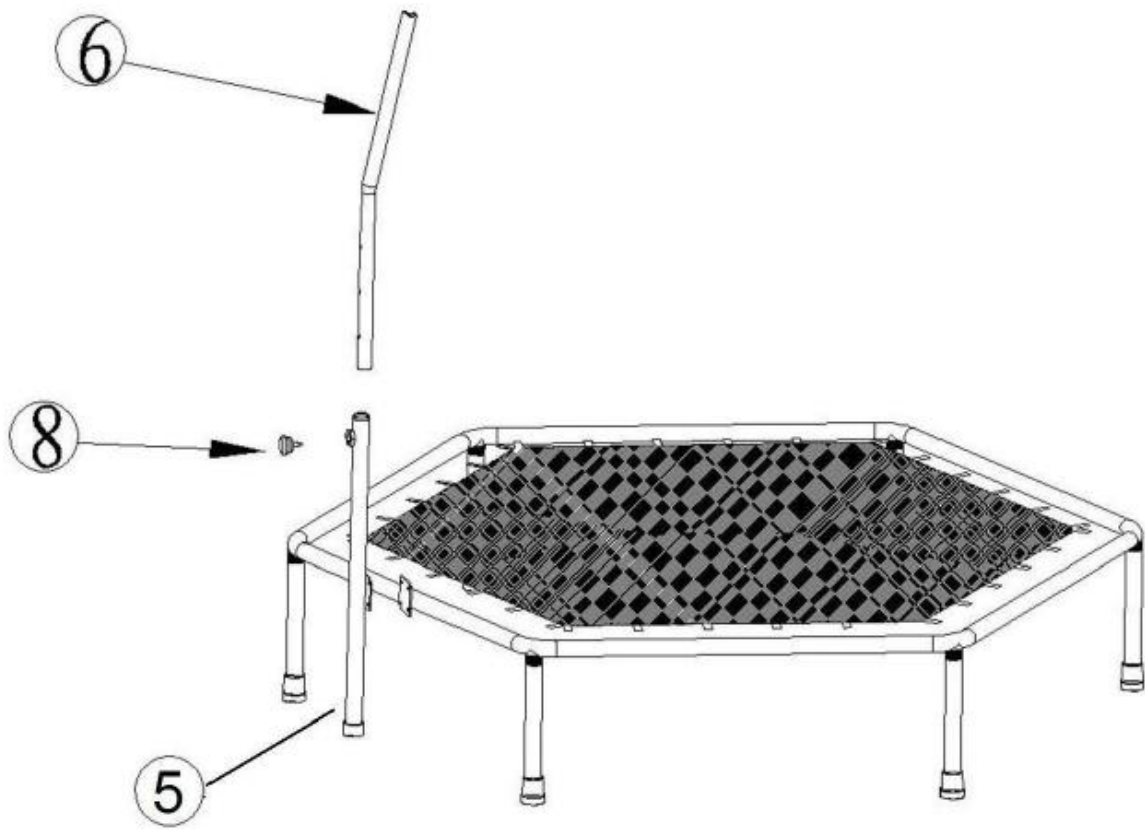

Step 7

Attach the handle (7) to the upper part of the handle (6) with bolt (12).

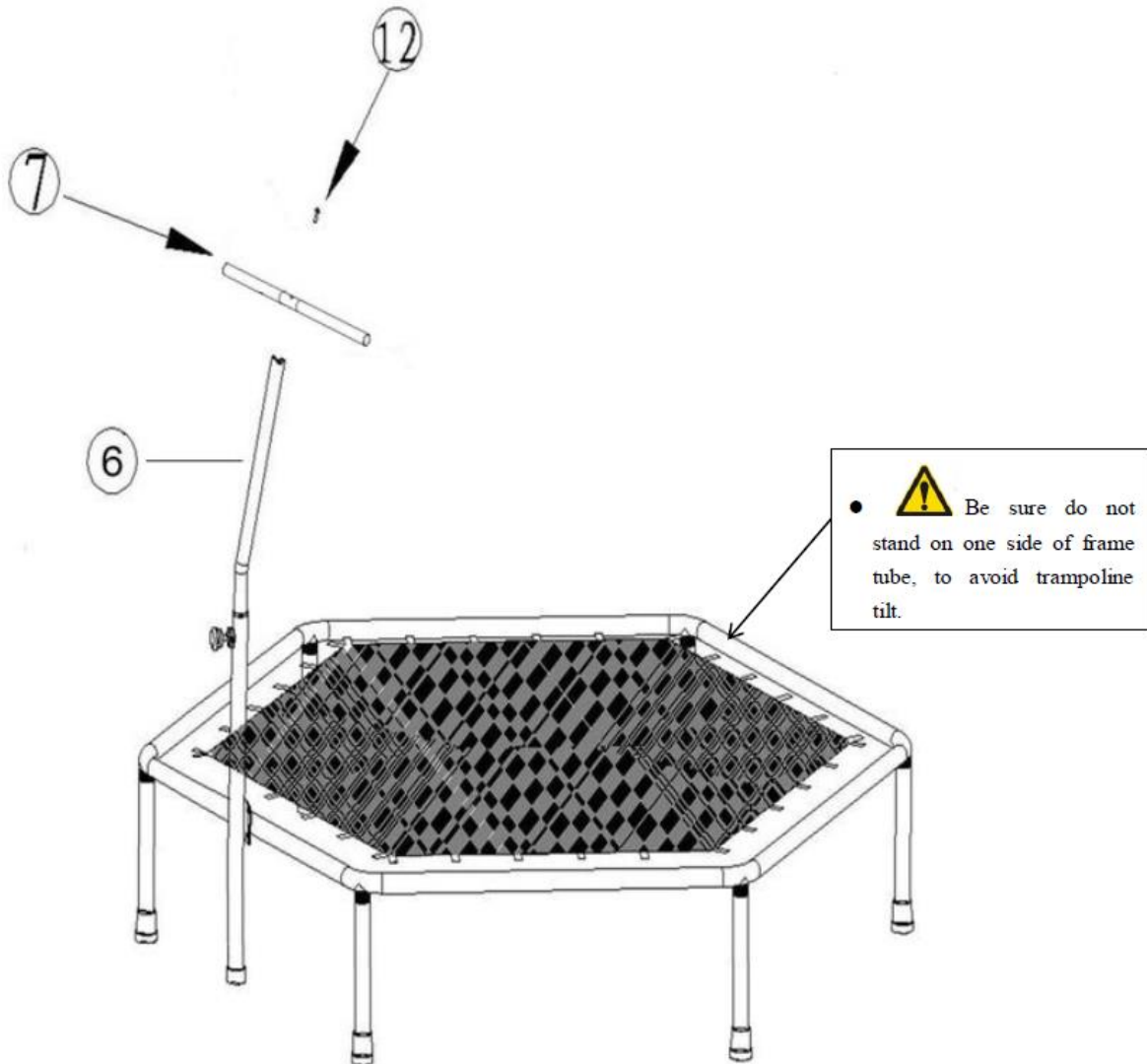

ENVIRONMENT PROTECTION

After the product lifespan expired or if the possible repairing is uneconomic, dispose it according to the local laws and environmentally friendly in the nearest scrapyards.

By proper disposal you will protect the environment and natural sources. Moreover, you can help protect human health. If you are not sure in correct disposing, ask local authorities to avoid law violation or sanctions.

TERMS AND CONDITIONS OF WARRANTY, WARRANTY CLAIMS

General Conditions of Warranty and Definition of Terms

All Warranty Conditions stated here under determine Warranty Coverage and Warranty Claim Procedure. Conditions of Warranty and Warranty Claims are governed by Act No. 89/2012 Coll. Civil Code, and Act No. 634/1992 Coll., Consumer Protection, as amended, also in cases that are not specified by these Warranty rules.

The seller is SEVEN SPORT s.r.o. with its registered office in Strakonická street 1151/2c, Prague 150 00, Company Registration Number: 26847264, registered in the Trade Register at Regional Court in Prague, Section C, Insert No. 116888.

According to valid legal regulations it depends whether the Buyer is the End Customer or not.

“The Buyer who is the End Customer” or simply the “End Customer” is the legal entity that does not conclude and execute the Contract in order to run or promote his own trade or business activities.

“The Buyer who is not the End Customer” is a Businessman that buys Goods or uses services for the purpose of using the Goods or services for his own business activities. The Buyer conforms to the General Purchase Agreement and business conditions.

These Conditions of Warranty and Warranty Claims are an integral part of every Purchase Agreement made between the Seller and the Buyer. All Warranty Conditions are valid and binding, unless otherwise specified in the Purchase Agreement, in the Amendment to this Contract or in another written agreement.

Warranty Conditions

Warranty Period

The Seller provides the Buyer a 24 months Warranty for Goods Quality, unless otherwise specified in the Certificate of Warranty, Invoice, Bill of Delivery or other documents related to the Goods. The legal warranty period provided to the Consumer is not affected.

By the Warranty for Goods Quality, the Seller guarantees that the delivered Goods shall be, for a certain period of time, suitable for regular or contracted use, and that the Goods shall maintain its regular or contracted features.

The Warranty does not cover defects resulting from (if applicable):

- User's fault, i.e. product damage caused by unqualified repair work, improper assembly, insufficient insertion of seat post into frame, insufficient tightening of pedals and cranks
- Improper maintenance
- Mechanical damages
- Regular use (e.g. wearing out of rubber and plastic parts, moving mechanisms, joints, wear of brake pads/blocks, chain, tires, cassette/multi wheel etc.)
- Unavoidable event, natural disaster
- Adjustments made by unqualified person
- Improper maintenance, improper placement, damages caused by low or high temperature, water, inappropriate pressure, shocks, intentional changes in design or construction etc.

Warranty Claim Procedure

The Buyer is obliged to check the Goods delivered by the Seller immediately after taking the responsibility for the Goods and its damages, i.e. immediately after its delivery. The Buyer must check the Goods so that he discovers all the defects that can be discovered by such check.

When making a Warranty Claim the Buyer is obliged, on request of the Seller, to prove the purchase and validity of the claim by the Invoice or Bill of Delivery that includes the product's serial number, or eventually by the documents without the serial number. If the Buyer does not prove the validity of the Warranty Claim by these documents, the Seller has the right to reject the Warranty Claim.

If the Buyer gives notice of a defect that is not covered by the Warranty (e.g. in the case that the Warranty Conditions were not fulfilled or in the case of reporting the defect by mistake etc.), the Seller is eligible to require a compensation for all the costs arising from the repair. The cost shall be calculated according to the valid price list of services and transport costs.

If the Seller finds out (by testing) that the product is not damaged, the Warranty Claim is not accepted. The Seller reserves the right to claim a compensation for costs arising from the false Warranty Claim.

In case the Buyer makes a claim about the Goods that is legally covered by the Warranty provided by the Seller, the Seller shall fix the reported defects by means of repair or by the exchange of the

damaged part or product for a new one. Based on the agreement of the Buyer, the Seller has the right to exchange the defected Goods for a fully compatible Goods of the same or better technical characteristics. The Seller is entitled to choose the form of the Warranty Claim Procedures described in this paragraph.

The Seller shall settle the Warranty Claim within 30 days after the delivery of the defective Goods, unless a longer period has been agreed upon. The day when the repaired or exchanged Goods is handed over to the Buyer is considered to be the day of the Warranty Claim settlement. When the Seller is not able to settle the Warranty Claim within the agreed period due to the specific nature of the Goods defect, he and the Buyer shall make an agreement about an alternative solution. In case such agreement is not made, the Seller is obliged to provide the Buyer with a financial compensation in the form of a refund.

CZ
SEVEN SPORT s.r.o.

Registered Office: Strakonická 1151/2c, Praha 5, 150 00, ČR
Headquarters: Dělnická 957, Vítkov, 749 01
Warranty & Service: Čermenská 486, Vítkov 749 01

CRN: 26847264
VAT ID: CZ26847264

Phone: +420 556 300 970
E-mail: eshop@insportline.cz
reklamace@insportline.cz
servis@insportline.cz

Web: www.inSPORTline.cz

SK
inSPORTline s.r.o.

Headquarters, warranty & service center: Električná 6471, Trenčín 911 01, SK

CRN: 36311723
VAT ID: SK2020177082

Phone: +421(0)326 526 701
E-mail: objednavky@insportline.sk
reklamacie@insportline.sk
servis@insportline.sk

Web: www.inSPORTline.sk