

SELECTION PRO

CONNECTED STRENGTH

LEG EXTENSION

User manual



The Wellness Company

Contents

Important safety instructions	3
Personal safety	5
Identification of the manufacturer and equipment	8
Description of the equipment.....	9
Technical data.....	10
Place of installation	11
Fitting the number holder	12
Lifting and moving the equipment	13
Adjusting the equipment.....	15
Routine maintenance	16
Replacing the padded parts.....	17
Replacing the cable.....	18
Adjusting the cable tension	20
Removing the rear protective weight stack panel	21
Technical Service	23
Storage	24
Disposal	25
Using the equipment	26

Important safety instructions

You should always consult with a qualified and licensed medical professional or healthcare practitioner before starting any nutritional, diet, stretching or exercise program. You are advised to investigate and inform yourself about any health related actions and choices you make.

Read all instructions before using the equipment. These instructions were written to ensure your safety and to protect the equipment. Equipment is intended for commercial use.



WARNING

To reduce the risk of injury, take the following precautions.

The products in the Selection range are units of fixed weight training equipment units that can be used for body-building or sculpting, physical activity aimed at keeping in shape, physical education and training for specific competitions and sports.

The equipment must be used by only one user at a time.

Use any equipment only for its intended use as described in the user manual. Only perform the exercises for which the equipment has been designed, following the instructions given in the manual. Any other use is to be considered improper and therefore dangerous.

Do not use attachments not recommended by the manufacturer.

The equipment must be installed and used in a place in which access and supervision are specifically controlled by the owner.

Do not allow unsupervised children close to the equipment.

Close supervision is necessary when any equipment is used by, on or near children or disabled persons.

Never operate any equipment if it has damaged power supply cord, if it is not working properly or if it has been dropped or damaged. In these circumstances, contact the Technogym Technical Support service.

Important safety instructions

Keep hands away from moving parts.

Never drop or insert any object into any opening.

Do not use outdoors. Do not leave the equipment outdoors, exposed to the elements. Do not expose the equipment to water jets.

The maximum user weight is 397 lb (180 kg).

Personal safety

Completely assemble the equipment before using it.

Maintain the equipment in good working condition.

Before each use check the equipment, check that the cable is correctly routed inside the races of all the pulleys and the state of wear of the cable. If there are signs of wear, contact the Technogym Technical Support service.

Do not continue to operate the equipment when it is not working properly.

Do not attempt to service the equipment yourself other than the maintenance instructions found in the user manual.

Assemble and operate the equipment on a solid, level surface.

Do not put anything on the frame.

Use of the equipment is subject to a medical examination in relation to the intended type of exercise, and compliance with the conditions of use indicated by the manufacturer.

Persons suffering from certain physical conditions may only use the equipment under the strict supervision of a specialist doctor.

Before starting an exercise, make sure your position on the equipment is correct, and be careful with any components that might constitute an obstruction.

Wear proper exercise clothing and shoes during a workout: no garments that impede perspiration and no loose clothing. Tie long hair back. Keep garments or towels away from moving parts.

Choose suitable exercises for your physical characteristics and state of health, starting with light loads.

Do not overexert yourself or work to exhaustion. If you feel any pain or abnormal symptoms, stop your workout immediately and consult your physician.

Make sure that the load selection pin is fully inserted. Use only the pin provided by the manufacturer. Contact the staff for any questions.

Only remove the pin when the weight stack is in the rest position. The weight stack is in the rest position when both the weights and the crosspiece are not in the air. If the weight stack is not in the rest position, contact floor staff and do NOT use the equipment.

Personal safety

The weight stack is covered externally with protective panels. Do NOT use the equipment if even only one of them is missing.

The instruction label must be applied on each piece of equipment. Technogym declines all responsibility in the event of the equipment being used before the instruction label has been affixed.

When the equipment is being used, DO NOT use the adjustment lever (A), DO NOT make the adjustment.

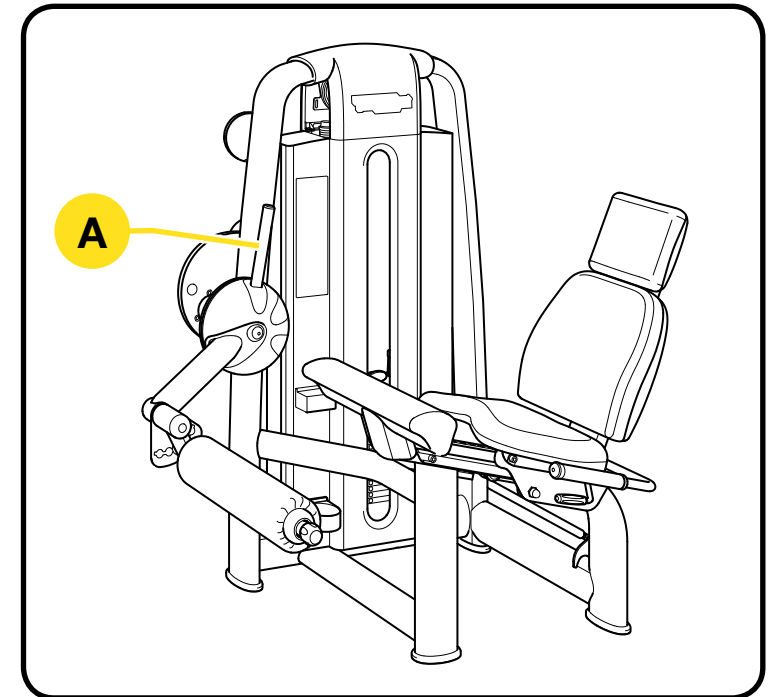

Pay particular attention to the parts of the equipment with labels indicating “BEWARE OF CRUSHING”.

 This symbol accompanies safety warnings. It is used to draw attention to potential risks of personal injury. Pay attention to all safety warnings accompanied by this symbol to avoid possible injury.

WARNINGS

During all operations involving transport, maintenance and cleaning, pay attention to any part of the equipment where body parts may become trapped.

Attention must be paid to the labels attached to the equipment, as they provide information about possible risks and hazards.

We recommend immediately replacing the labels when they become damaged or difficult to read.

Technogym is not responsible for any damage due to any failures or damage caused by unauthorized service, misuse, accident, negligence, improper assembly or installation, debris resulting from construction activities in the product’s environment, rust or corrosion as a result of the product’s location, alterations or modifications without Technogym’s written authorisation or for failure on your part to use, operate and maintain the products as set out in this User Manual.



⚠ WARNING

SERIOUS INJURIES CAN OCCUR ON THIS EQUIPMENT.

Before using the equipment, read all the warnings and all the instructions. Refer to the user manual for additional warnings and safety information.

Do NOT modify the equipment.

If you feel any pain or abnormal symptoms, stop your workout immediately and consult your physician.

Keep body, hair and clothing away from all moving parts.

Check the equipment before use.

Do not use the equipment if you see signs of wear or damages. In this case notify the staff immediately.

For selectorized strength equipment that employ weight stack: before using the equipment check that the cables are correctly routed inside the races of all the pulleys, and check the state of wear of the cables and their connections.

If you see signs of wear, notify the staff immediately.

Be certain that the weight pin is completely inserted. Use only the pin provided by the manufacturer. If unsure, seek assistance.

Never pin the weights in an elevated position. DO NOT use the equipment if found in this condition. Seek assistance from floor staff.

For selectorized strength equipment that employ discs: before use check that the discs are correctly and symmetrically secured. If unsure, seek assistance.

Do not use attachments not recommended by the manufacturer.

Do not allow children unsupervised access to the equipment. Close supervise teenagers.

DO NOT REMOVE THIS LABEL. REPLACE IF DAMAGED.

Identification of the manufacturer and equipment

The equipment and manufacturer identification plate, affixed on the right side of the seat, gives the following details:

- A** Manufacturer's name and address
- B** CE Mark
- C** Serial number
- D** Maximum user weight
- E** Equipment classification
- F** Consultation of user manual required

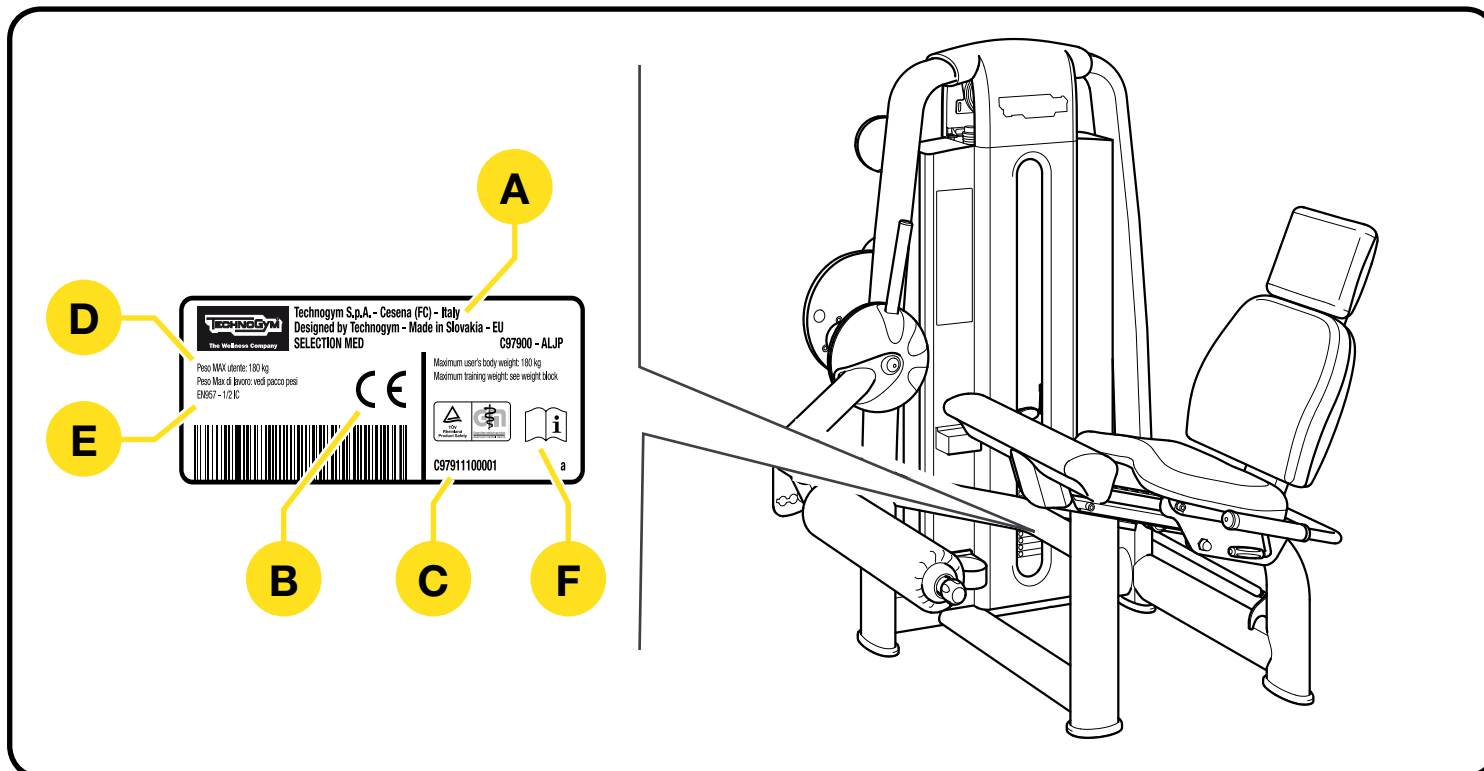

Description of the equipment

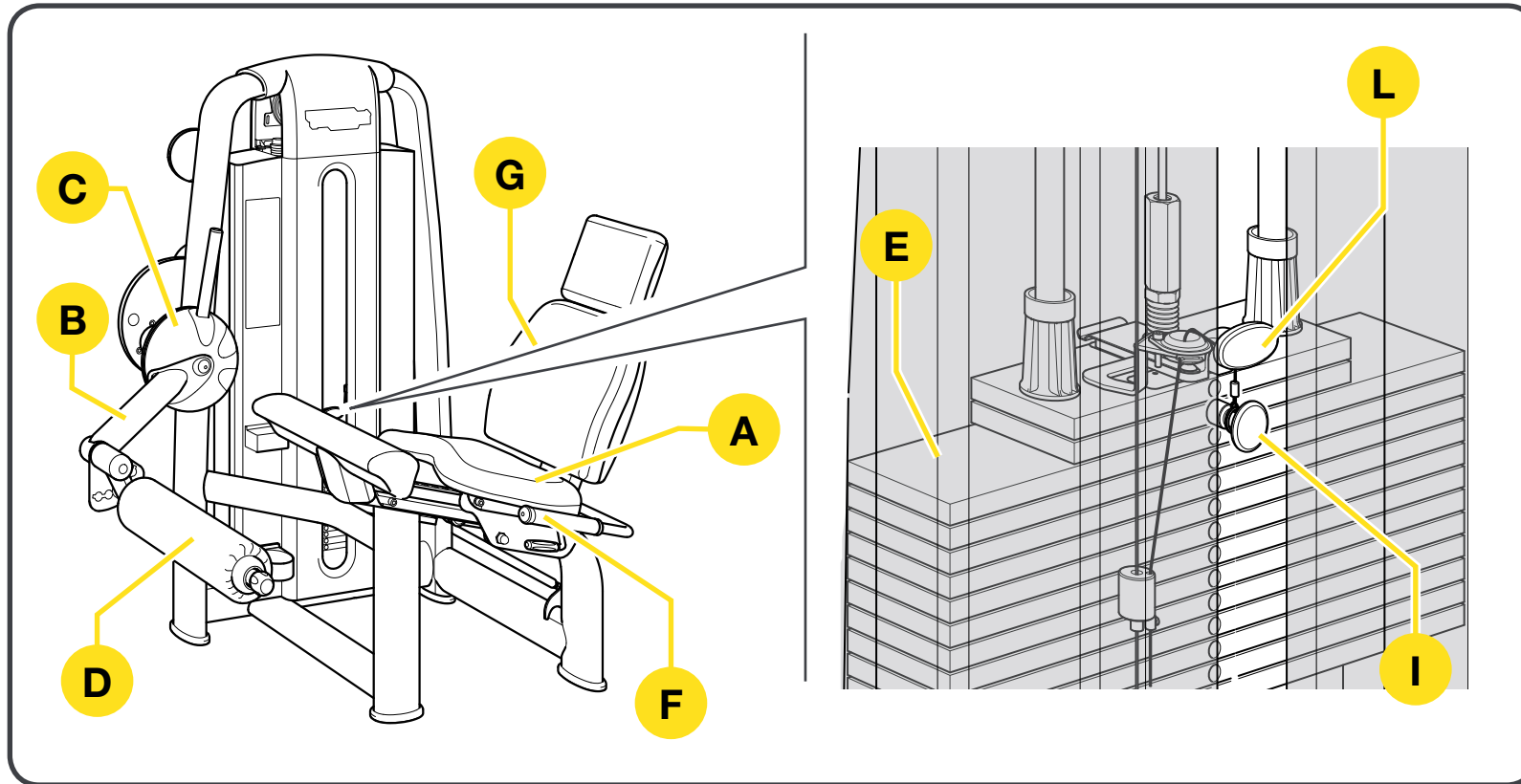

- A Seat:** where the user sits to perform the exercise. It has a backrest (G).
- B Exercise lever:** operated by the user by means of the roller (D).
- C ROM device:** allows the starting position to be adjusted, therefore the Range of Motion.
- E Weight stack:** lever (B), operated by the user, moves the weights along two guide rails by means of a cable. A pin (I) is used to select the workload, to adjust the exercise effort level. The cursor (L) is used to vary the selected workload by 2.5 kg.
- F Side handgrips:** the user can enhance the comfort by holding them during the exercise.

Technical data

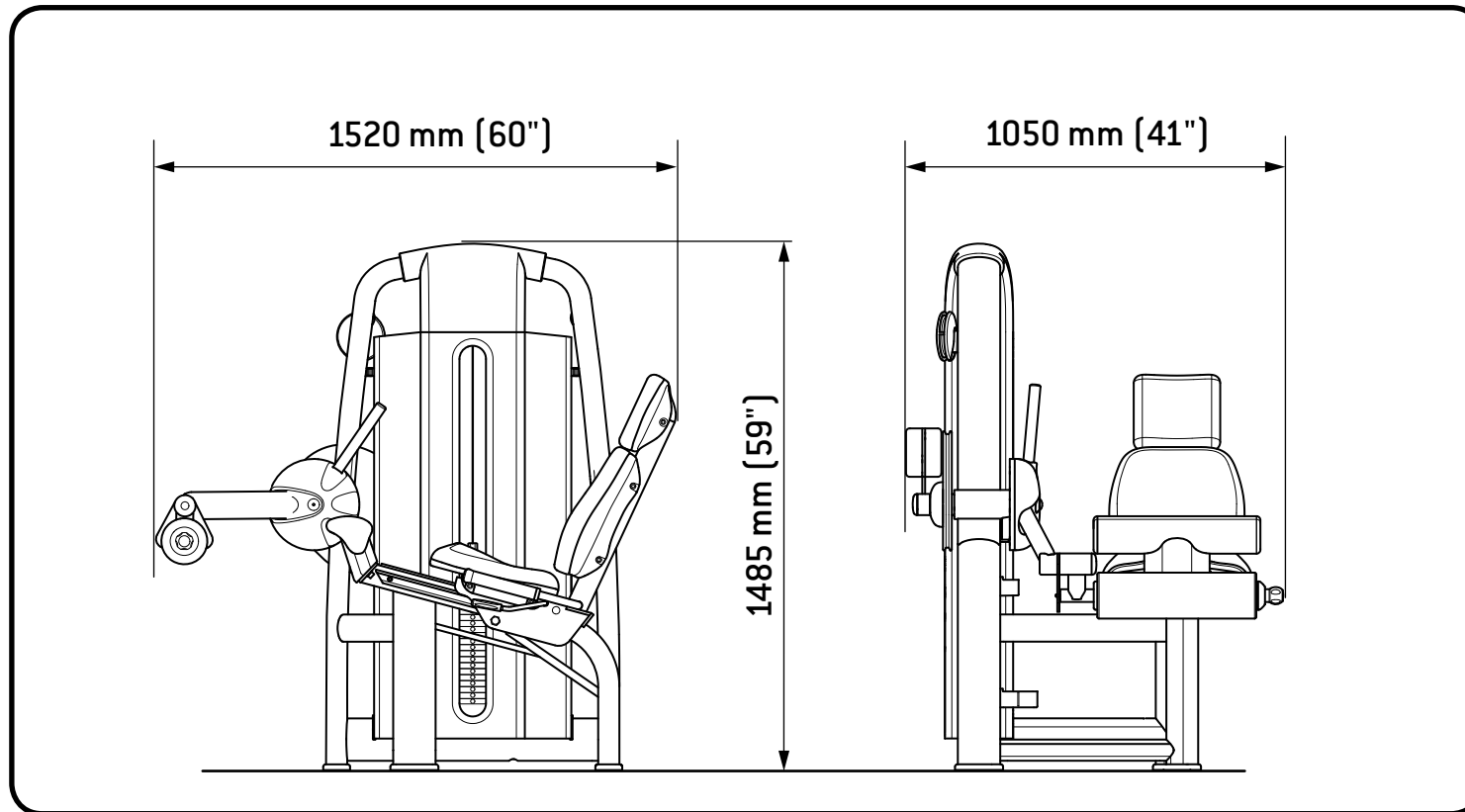

263 kg (580 lb)



+ 293 kg (646 lb)

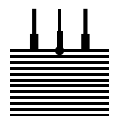

95 kg (190 lb)

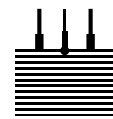

+ 125 kg (250 lb)

Place of installation

To ensure safe, comfortable and effective use of the equipment, the place of installation must comply with certain specific requirements; in particular, before choosing where to install the equipment we recommended that you check that the following conditions are available:

- a **temperature** between +10°C and +25°C;
- sufficient ventilation to maintain a humidity level between 20% and 90%, when the equipment is in use;
- sufficient **lighting** to make the area a safe and relaxing place to exercise;
- sufficient **clearance** on all sides of the equipment, taking into account its maximum dimensions when in use, to ensure safety;
- a flat, stable and vibration-free floor surface, with sufficient load bearing capacity for the equipment's weight.

If the equipment is to be installed in a **public recreation area**, the place of installation must comply with all the requirements of the regulations currently in force.



WARNINGS

The equipment must be installed and used in a place where access and supervision are specifically controlled by the owner.

When installing the equipment, use suitable personal protective equipment.

Fitting the number holder

Standing facing the equipment, attach the number holder on the left, on the cover of the weight pack guide rail.

Proceed as follows to apply the number holder:

- Remove the cover (A).
- Find the place (B) where the two screws are to be inserted.
- Use a drill to complete the holes.
- Refit the cover (A).
- Attach the number holder using the two screws (C).

The number holder is optional.

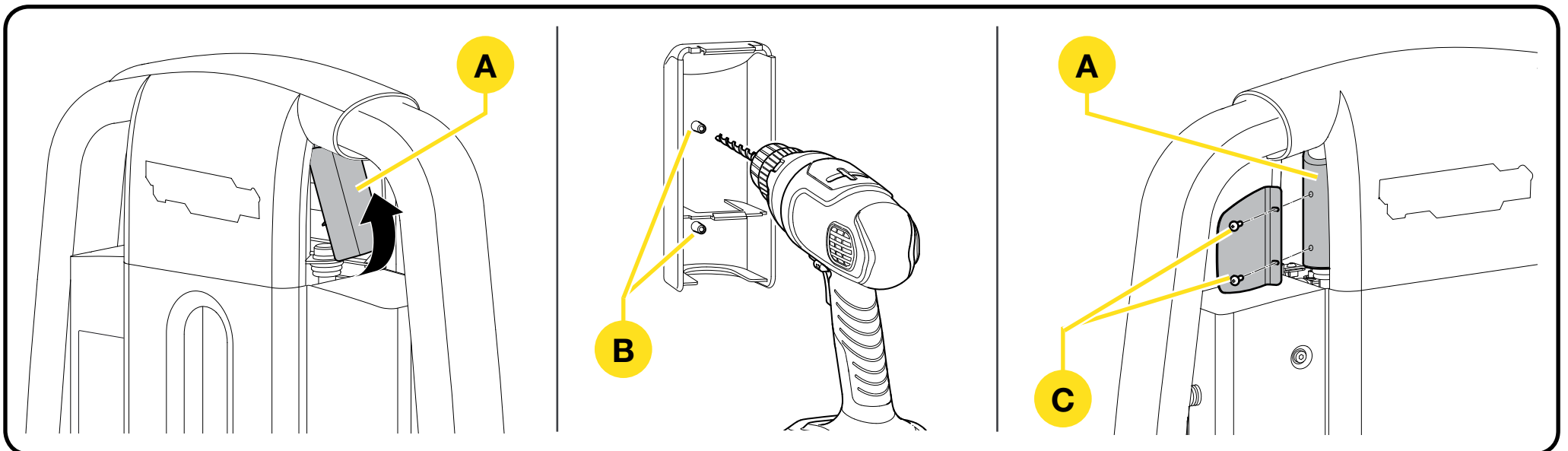

Lifting and moving the equipment

Snap-on castors (optional) must be used to move the equipment.



WARNINGS

Move the equipment very carefully, because it may become unstable and tip over.

Do not use the equipment with the castors fitted. The castors are to be used only for moving the equipment and must be removed before exercising on it.

The castors for moving the equipment snap on under the feet of the equipment, after it has been raised, and are held in place by the special straps.

Raise the equipment **on the weight stack side**, using a pallet truck or fork-lift truck; and for greater safety place a wedge under the frame to keep the equipment raised.

Insert the two fixed castors first on one side and then on the other side of the weight stack: fit castor stems (A) into the holes provided under the equipment feet, then push hard until they snap in.



WARNINGS

We recommend placing padded material between the frame and the wedge and between the frame and the machinery used to lift it.

The fixed castors must always be placed underneath the weight stack.

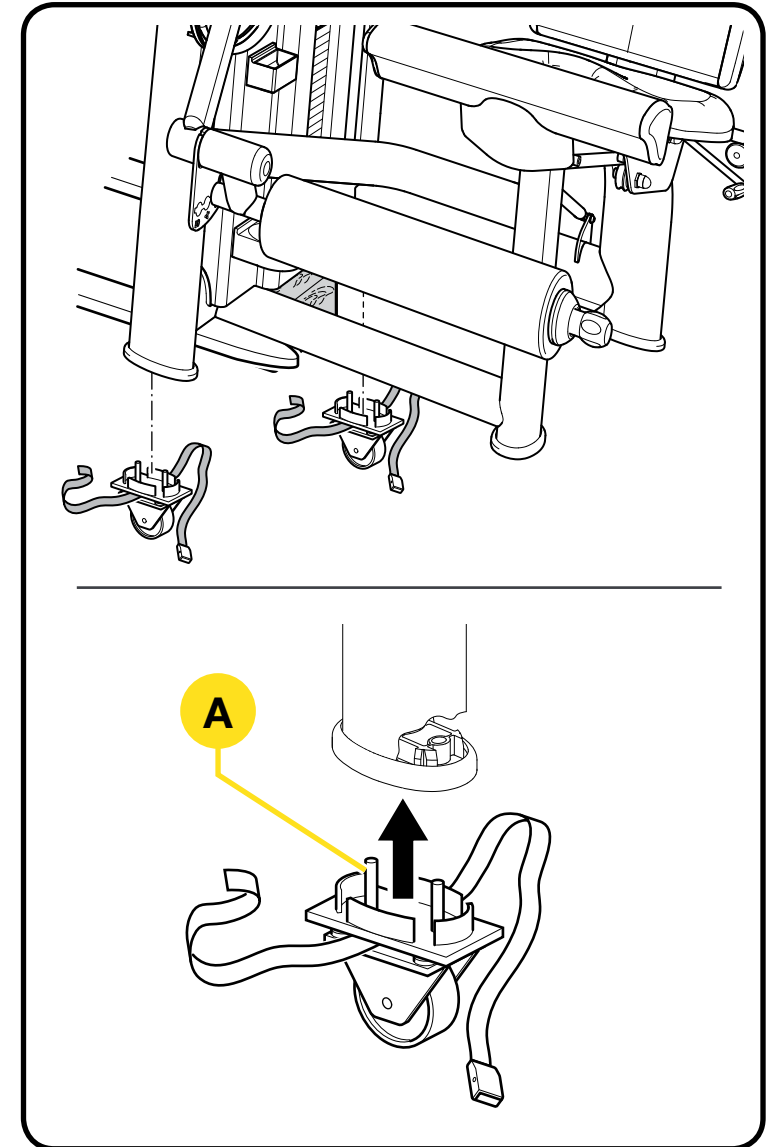

Lifting and moving the equipment

Proceeding in the same way, lift the equipment **on seat side** and insert the swivel castors.

Lastly, lift the equipment again, remove the safety wedges and place the wheels on the floor.



WARNINGS

When moving the equipment, we recommend pushing it only from the weight stack side, and not from any other side.

When lifting the equipment, do not press against the weight stack guard.

Do not use the adjustment lever to try to move the equipment: because it may cause DAMAGE and become unstable.

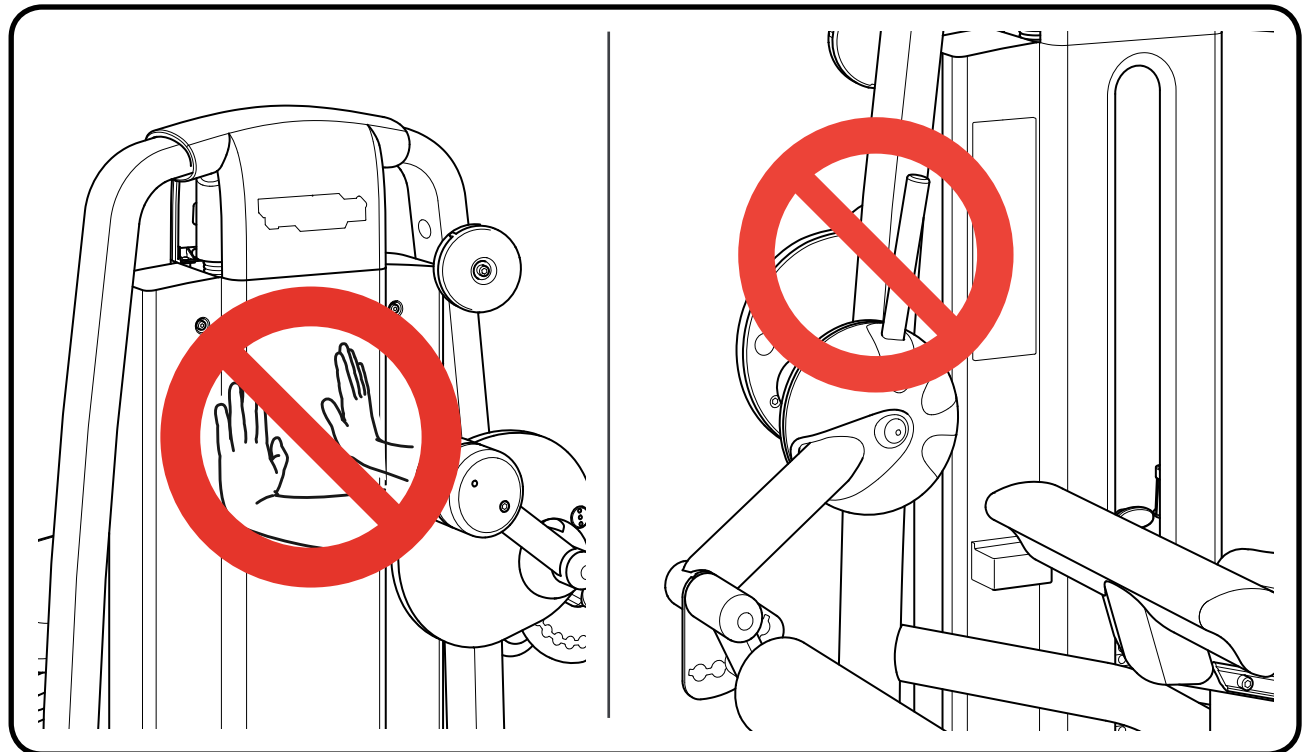
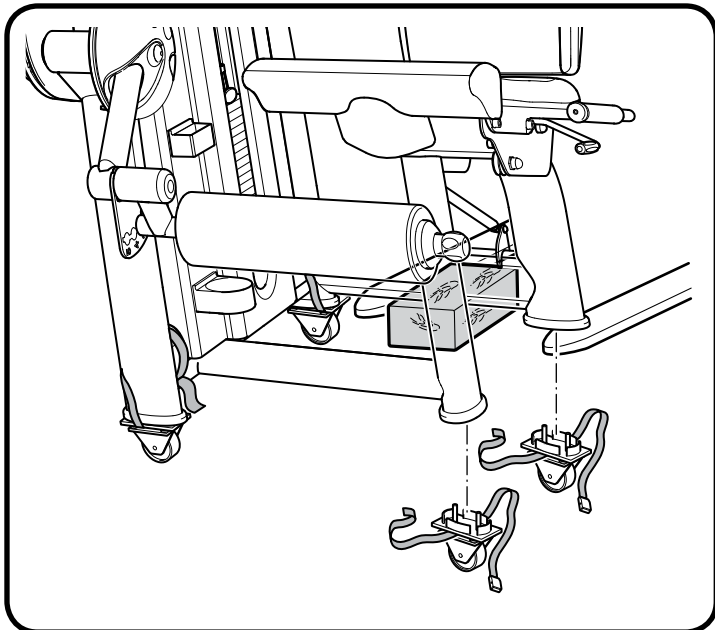

Adjusting the equipment

The equipment must be level for proper operation.

If necessary, use the adjuster screw located under foot **(A)**, clearly indicated by two raised arrows.

Raise the equipment and adjust the screw until the equipment is level.



WARNING

Given the weight of the equipment, we recommend that it should always be lifted by more than one person.

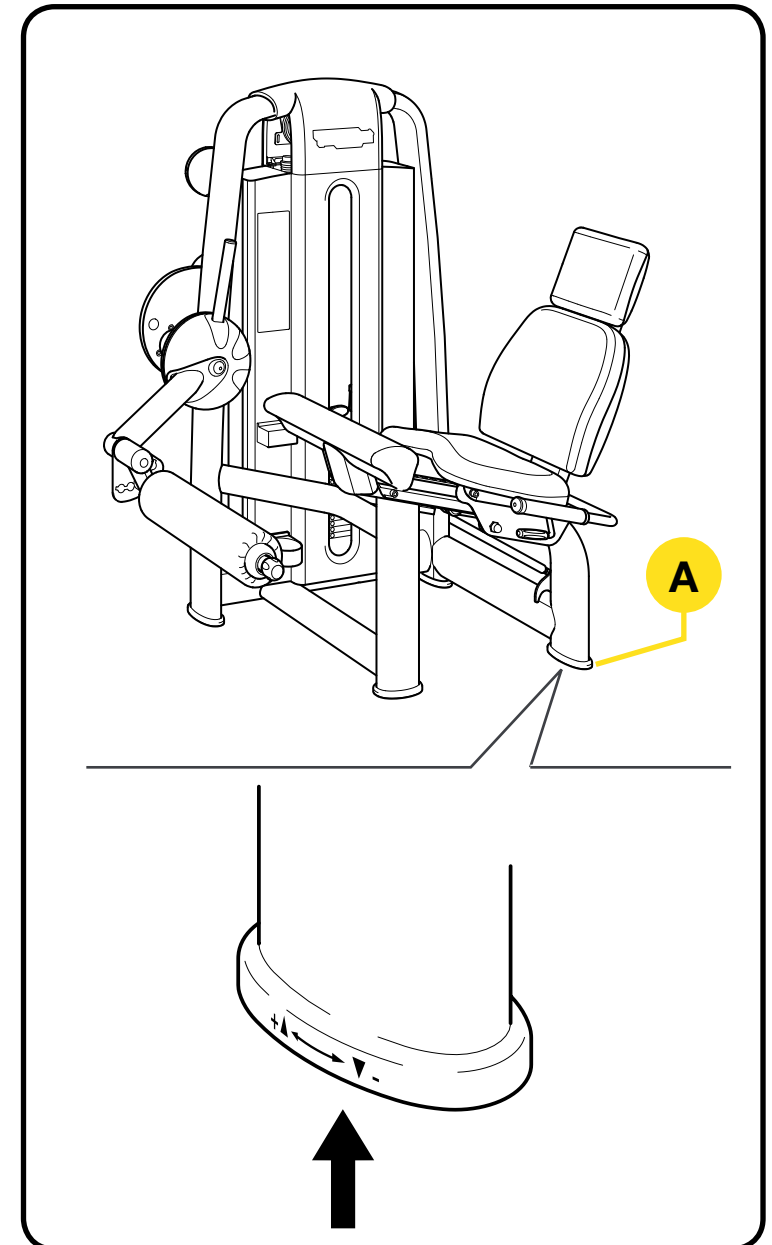

Routine maintenance



WARNINGS

The safety of the equipment is assured only on the condition that it is carefully inspected every two weeks for any signs of damage and/or wear. Replace defective and worn components immediately, or alternatively remove the equipment from service.

The equipment should always be kept clean and free of dust, in compliance with good hygiene practice, especially if it is used in a gym or by more than one person.

Use a moist cloth or a sponge and mild soap to clean the padded parts.

Wipe the outside of the equipment every week using a damp sponge.

Do not use chemicals or solvents.



WARNING

Be careful not to rub too hard on the drawings and instructions shown on the labels.

Call in the Technogym Technical Support Service for instructions on any maintenance operations not described in this manual.

Replacing the padded parts

If any of the padding shows signs of wear, especially in the interests of hygiene, we recommend replacing them completely.

To replace the seat padding, unscrew the screws located on the opposite side of the padding.

Proceed as follows to replace the roller:

- remove the cap **(A)**;
- unscrew the screw **(B)**, inside the knob **(C)**;
- unscrew the cap **(D)**;
- remove the roller.

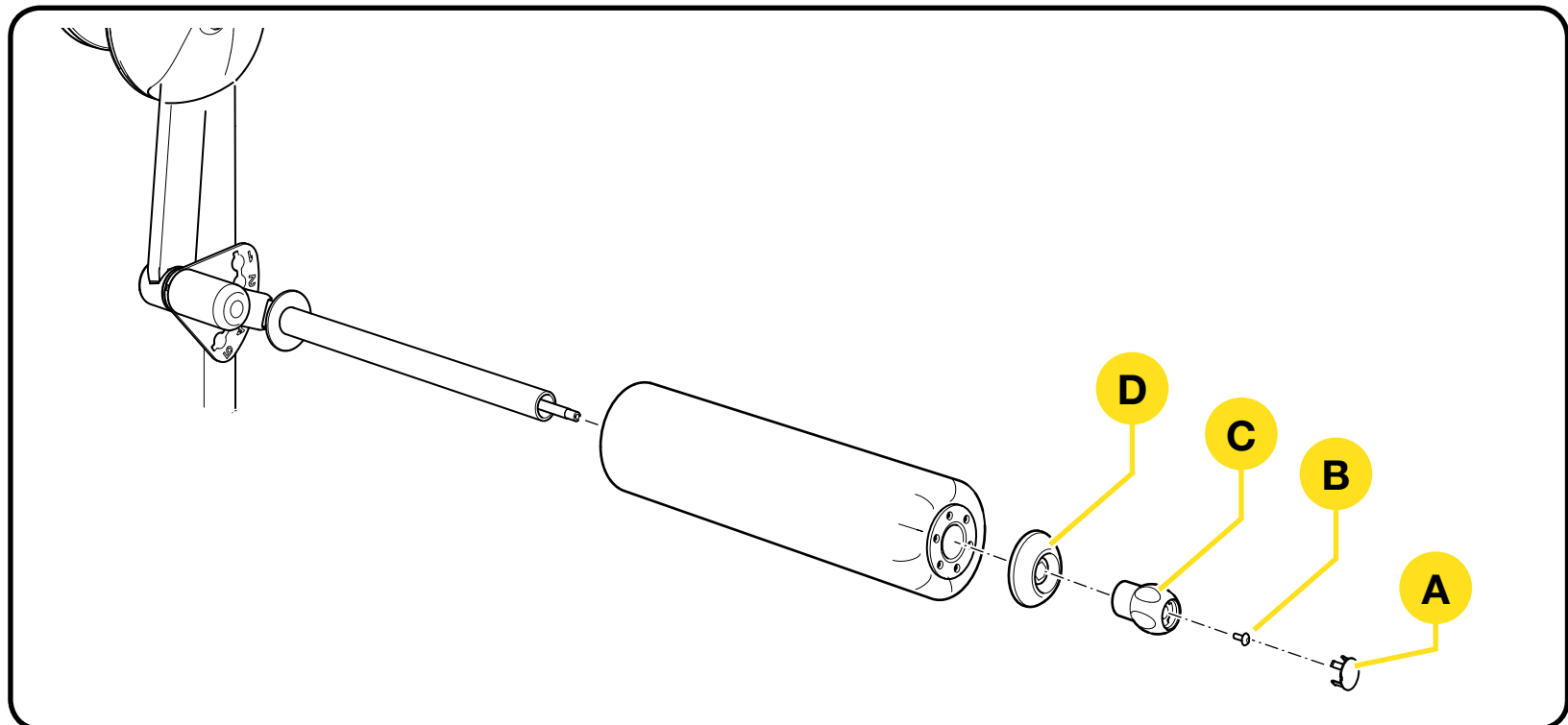

Replacing the cable

Cables must always be replaced at the first sign of wear, even if only the outer rubber protection is worn.



WARNINGS

Carefully check the state of the cables once a month.

ALWAYS use cables supplied directly by Technogym.

To replace the cable, you must:

- remove the rear protective weight stack panel;
- unscrew screws **(A)**;
- loosen lock nut **(B)** and loosen adjuster **(C)**;
- remove the weight stack cable from adjuster side;

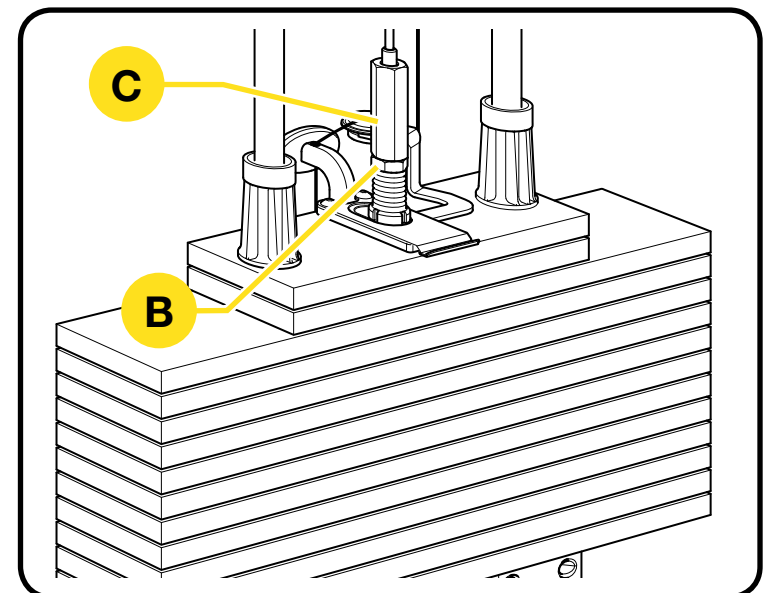
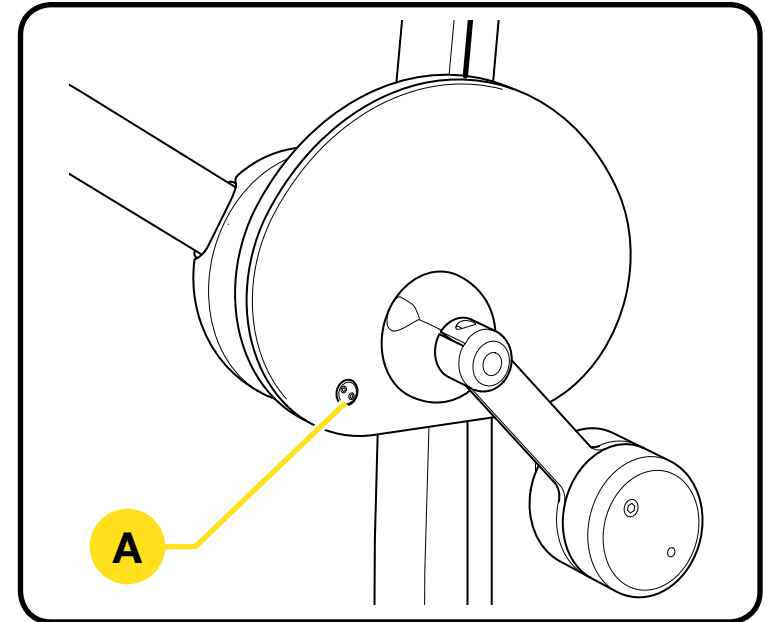

Replacing the cable

- insert the new cable from the adjuster side (ensuring that it follows the same route as the original cable, as shown in the illustration);
- tighten screws **(A)**;
- screw in adjuster **(C)** and screw on lock nut **(B)**;
- refit the protective panel on the weight stack.

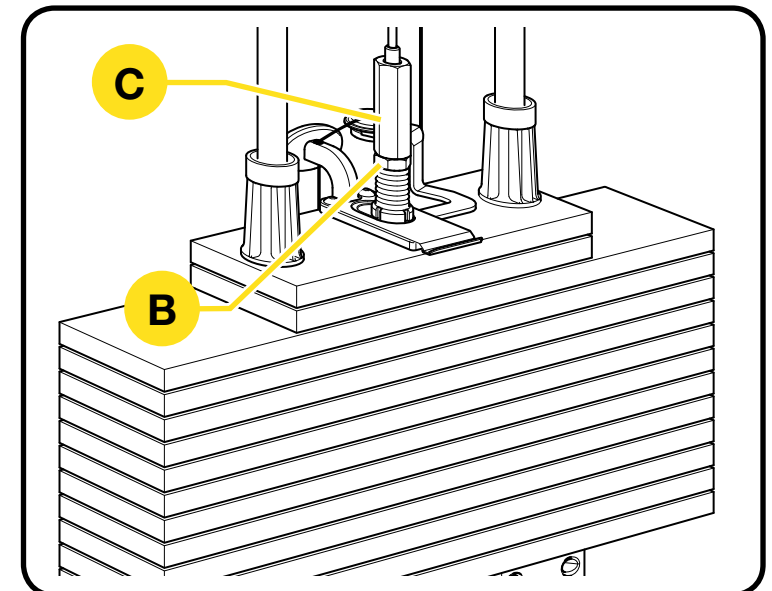
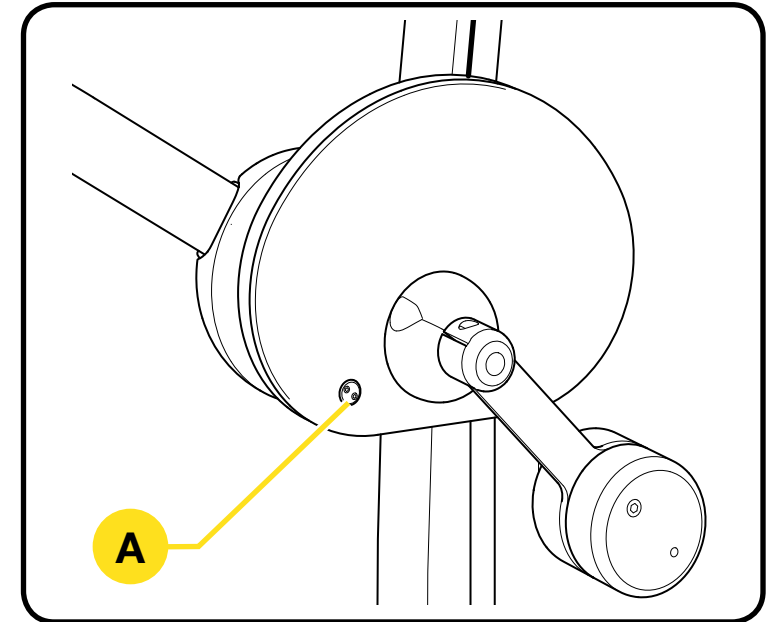
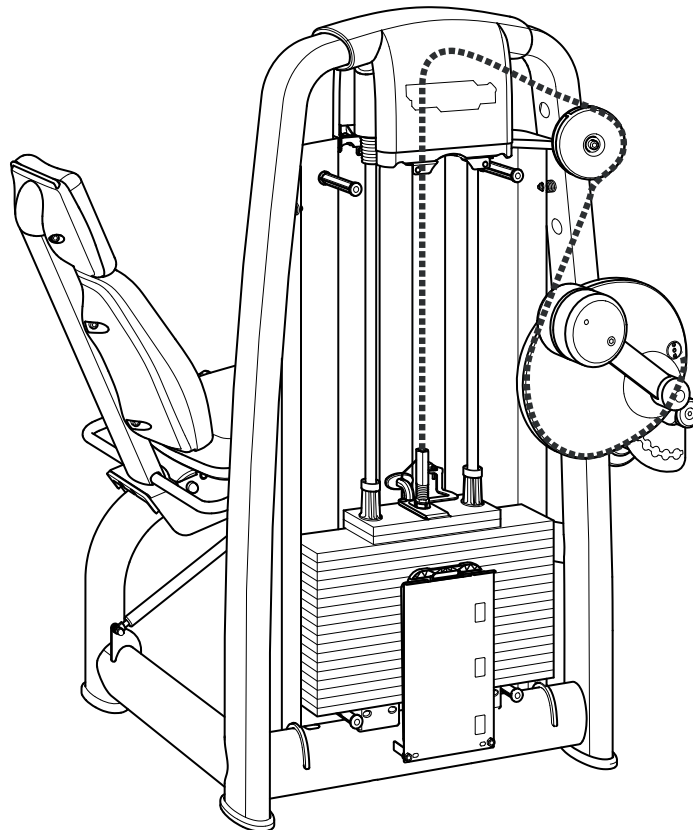

Adjusting the cable tension

Use the adjuster [C] to adjust the tension of the weight stack cable:

- loosen the locknut [B];
- tighten or loosen the adjuster [C] to correctly adjust the cable tension;
- tighten the locknut [B].



WARNING

To pull the cable taut after replacement, it may be helpful, when tightening the screws [A], to insert a thickness of approx. 10 mm (1/2") under the first weight in the weight stack.

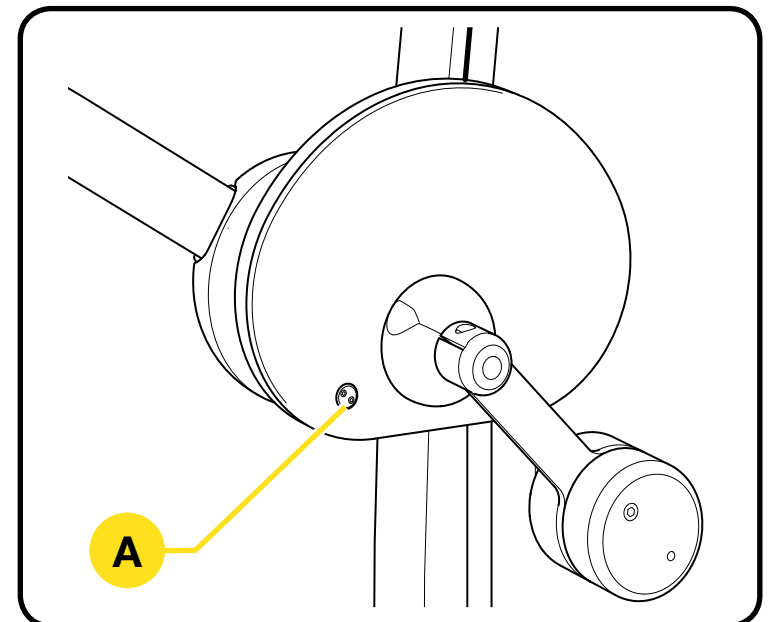
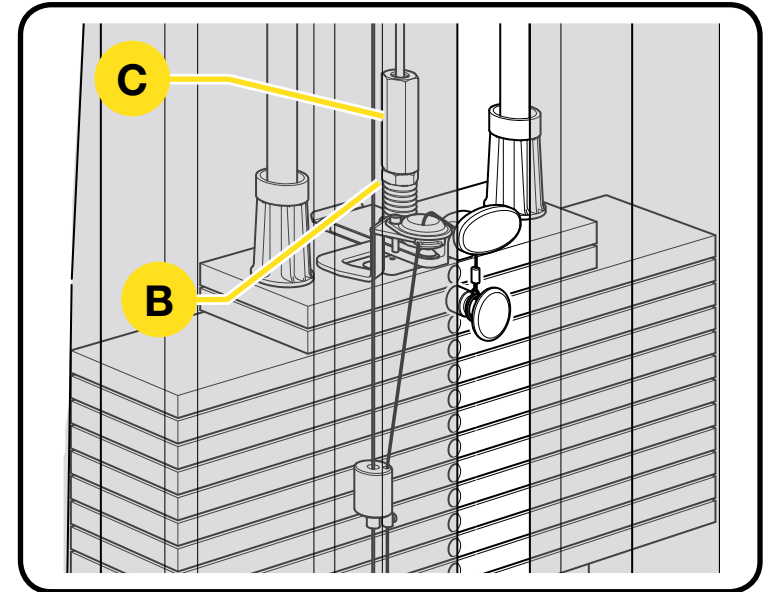

Removing the rear protective weight stack panel

Remove the rear protective weight stack panel to access the cable.

Do not use the product even if only one of the protective weight pack panels is missing.

Proceed as follows to remove the panel:

- unscrew the four screws **(C)**;
- unscrew the two screws **(D)**;

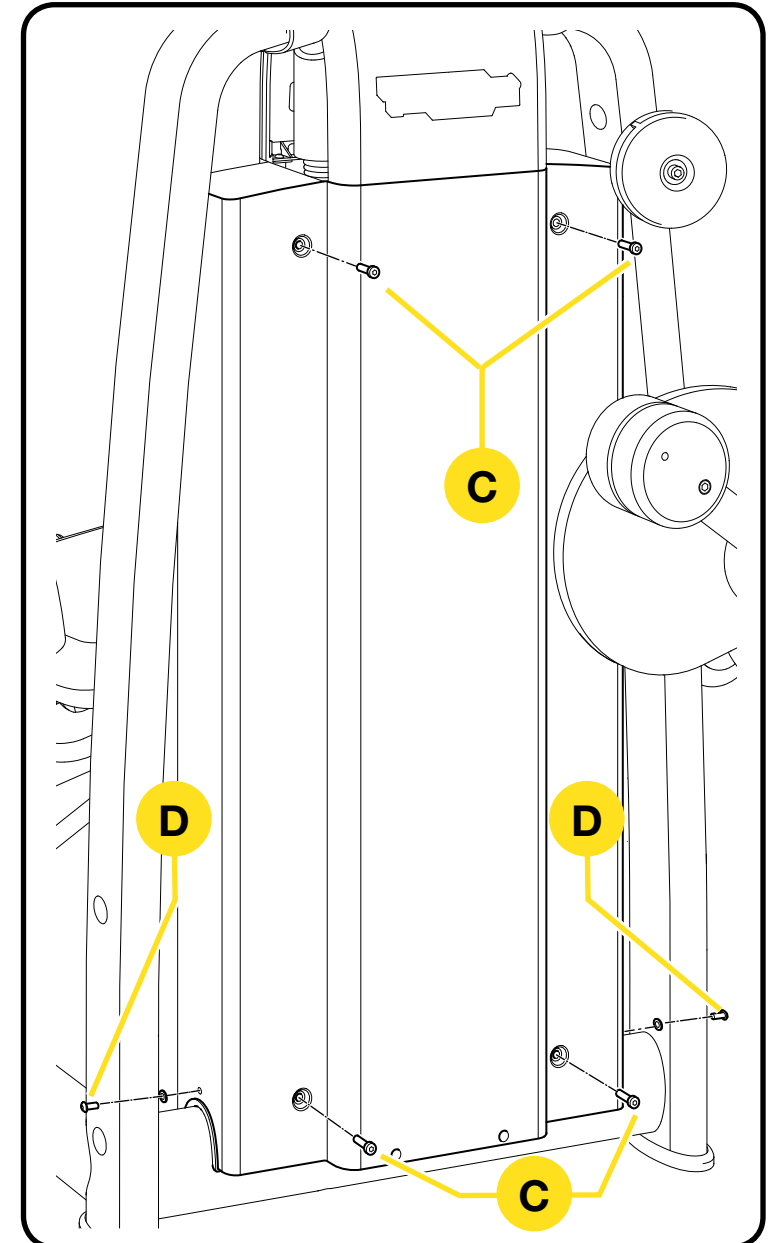

Removing the rear protective weight stack panel

- remove the two covers (E);
- loosen the two nuts (F);
- unscrew the two nuts (G);
- remove the panel.

To reassemble the panel, carry out the above steps in reverse order.

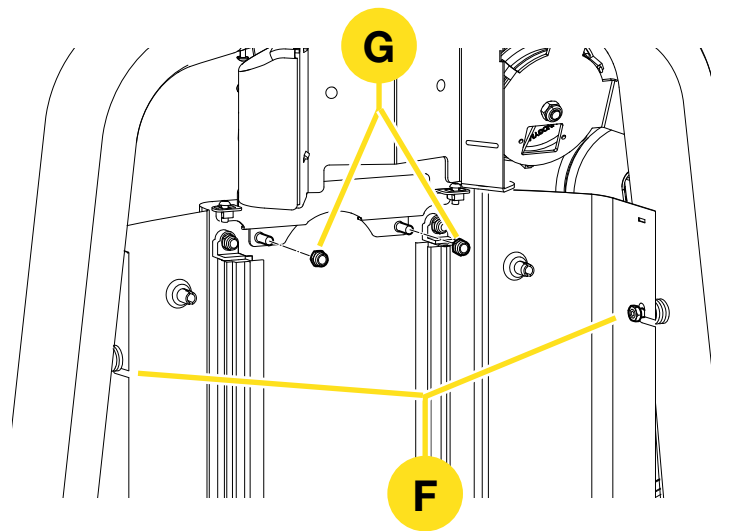
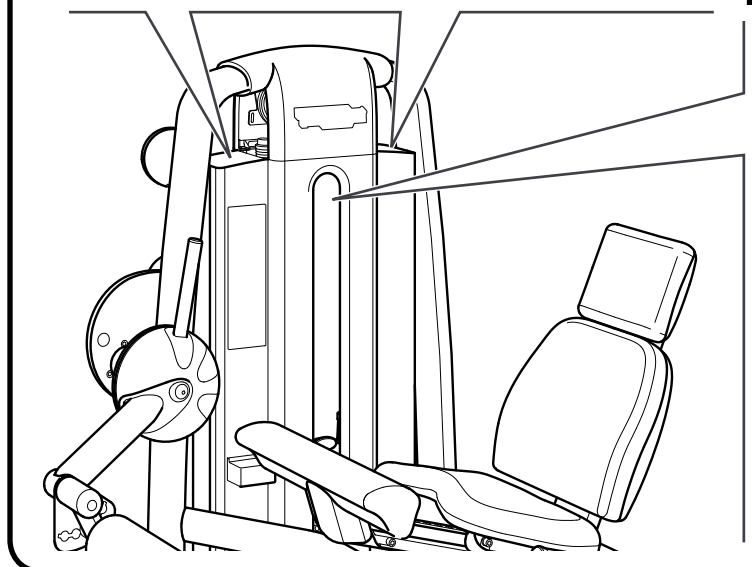
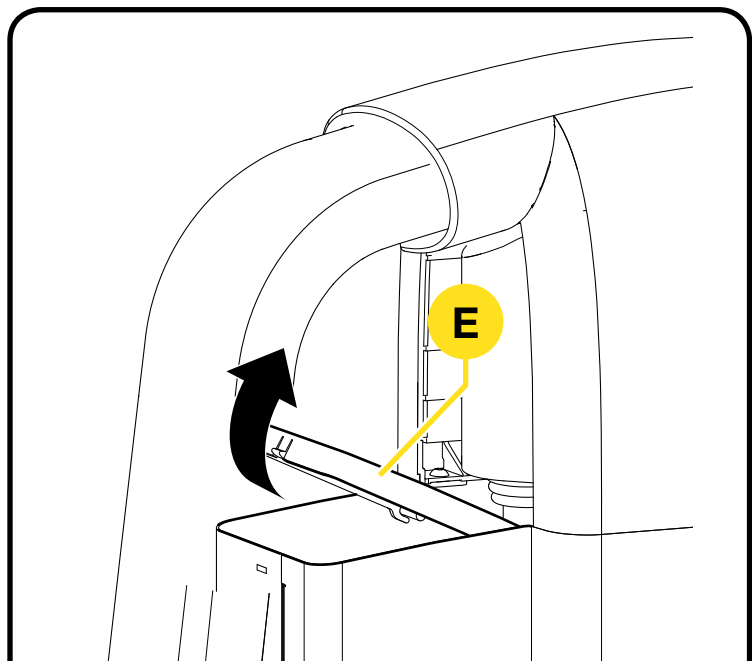

Technical Service

The Technogym Technical Support Service provides:

- telephone assistance;
- information on which service calls are covered and not covered by warranty;
- on-site assistance;
- sending of original spare parts.

**Technical Support Service
Technogym s.p.a.**

**Via Calcinaro 2861, 47521 Cesena Italy
tel: +39 0547 56047
<http://www.technogym.com/Support>**

When contacting the Technogym Technical Support Service, please specify the following details:

- equipment model,
- date of purchase,
- serial number,
- precise description of the problem.



WARNING

Any operations carried out by persons not authorized by Technogym on the equipment will invalidate the warranty.

Storage

If the equipment will not be used for a prolonged period, we recommend storing it:

- in a clean and dry place, covered with a cloth to protect it from dust;
- in an environment with a temperature between +10°C and +25°C and a humidity between 20% and 90%.

Use the original packing materials, to better preserve the equipment.

Disposal

It is always good practise to ensure that the equipment can never constitute a hazard; therefore do not leave the equipment where children may play with it.

Do not dump the equipment in the environment, or in public areas or private areas accessible to the public.

The equipment is made from recyclable materials such as steel, aluminium and plastic, which must be disposed of in the manner prescribed by the urban refuse collection regulations in force, by firms specialised in urban and environmental hygiene.

Using the equipment

Select the workload with the pin (F).

To access the seat comfortably push the button on the lever (A), and move the lever forward to lower the roller pads.

Lift the lever (B) under the left handgrip to move the seat backwards or forwards so that the back of your knees rest comfortably against the rest (C) provided on the seat; roller (D) must remain in front of your ankles.

Position the shin pad (D) slightly above the ankles by pulling the end knob (E).

Adjust the starting position with the lever (A).

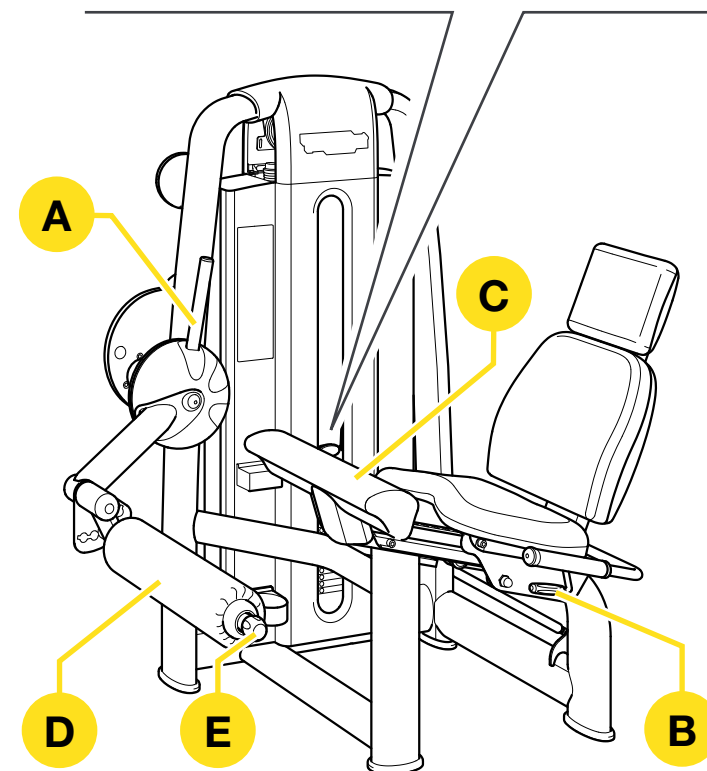
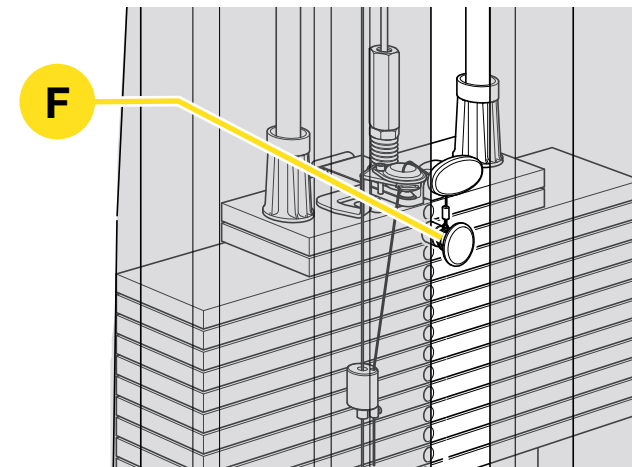

Using the equipment

Maintain a smooth controlled speed through the movement while staying in control of the weight.

For greater stability during the exercise, grasp the side handgrips.

Maintain control of the workload during the movement; during the return phase the weight stack must not return completely to the rest position.

Constantly control the speed of the movement; we recommend a slower speed during the return phase than during the approach phase.

At the end of the exercise, to get up more easily release and lower the lever (A).

When the equipment is in use, DO NOT use the adjustment lever (A), DO NOT make the adjustment.

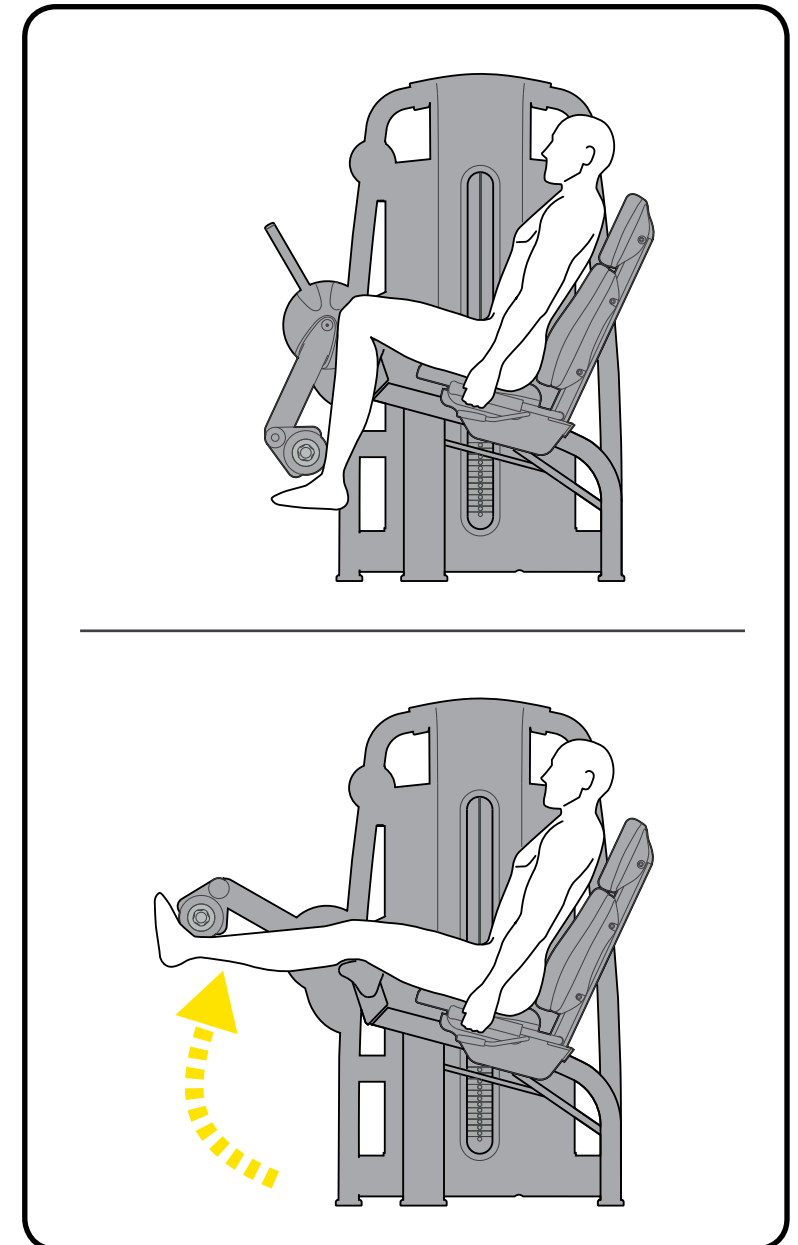
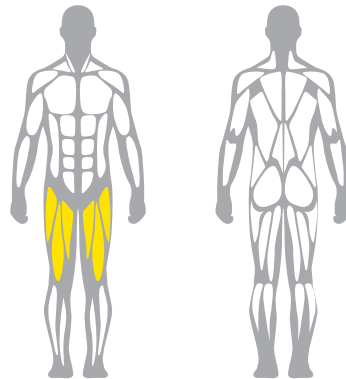

Using the equipment

For further information on use of the product, connect to the Technogym cloud.

Use the QR code or the NFC sensor to connect to the cloud.

NFC sensor

Activate the Internet connection on your device (for example, on your smartphone).

Identify the position of the NFC sensor on your device.

Place your personal device on the equipment, with its sensor over the NFC logo. In this way, the personal device will connect to the Technogym cloud.

To connect using NFC you must have installed the Technogym application on your personal device.

QR code

Activate the Internet connection on your device (for example, on your smartphone).

Open the QR code reader on your device and point the camera of the device at the code on the product.

In this way, the personal device will connect to the Technogym cloud.

To connect using the QR code, you must have installed the Technogym application on your personal device.



Leg Extension_en_AA
OSM00964



The Wellness Company