

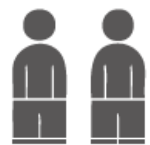

USER MANUAL – EN

IN 10666 Portable Basketball System inSPORTline Phoenix

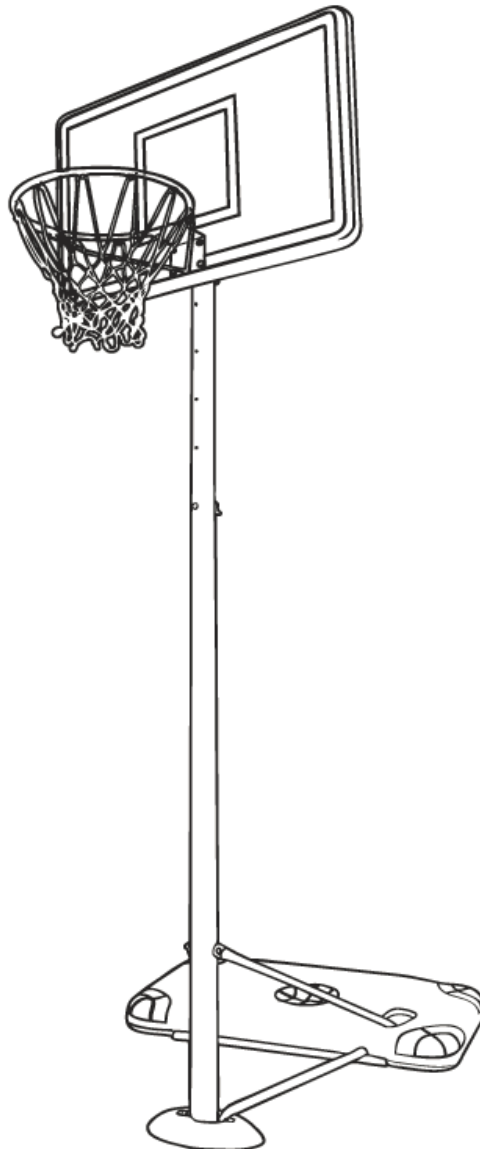

TWO ADULTS

CONTENTS

SAFETY INSTRUCTIONS..... 3
PARTS LIST 4
PRECAUTIONS..... 7
ASSEMBLY 7
TRANSPORT..... 12
TERMS AND CONDITIONS OF WARRANTY, WARRANTY CLAIMS..... 13

PREPARATION

PLEASE READ THIS PAGE CAREFULLY

Remove all parts and hardware from the carton and place them on a clean soft surface. Check carefully to make sure nothing is missing. Dispose of all packaging materials properly. Please recycle.

SAFETY INSTRUCTIONS

FAILURE TO FOLLOW THESE SAFETY INSTRUCTIONS MAY RESULT IN SERIOUS INJURY OR PROPERTY DAMAGE AND WILL VOID WARRANTY.

Owner must ensure that all players know and follow these rules for safe operation of the system.

To ensure safety, do not attempt to assemble this system without following the instructions carefully. Check entire box and inside all packing material for parts and/or additional instruction material. Before beginning ASSEMBLY, read the instructions and identify parts using the HARDWARE identifier and PARTS LIST in this document. Proper and complete assembly, use, and supervision are essential for proper operation and to reduce the risk of accident or injury. A high probability of serious injury exists if this system is not installed, maintained, and operated properly.









- If using a ladder during assembly, use extreme caution.
- Check base regularly for leakage. Slow leaks could cause the system to tip over unexpectedly.
- Seat the pole sections properly (if applicable). Failure to do so could allow the pole sections to separate during play and/or during transport of the system.
- Climate, corrosion or misuse could result in system failure.
- If technical assistance is required, contact Customer Service.
- Minimum operational height is 6' 6" (1.98m) to the bottom of backboard.

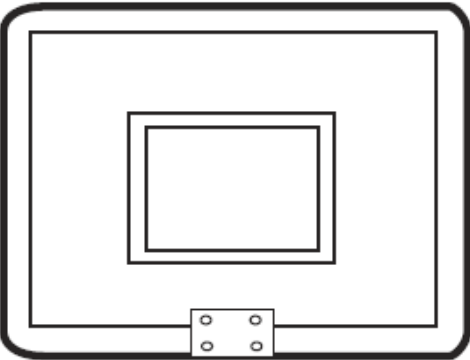
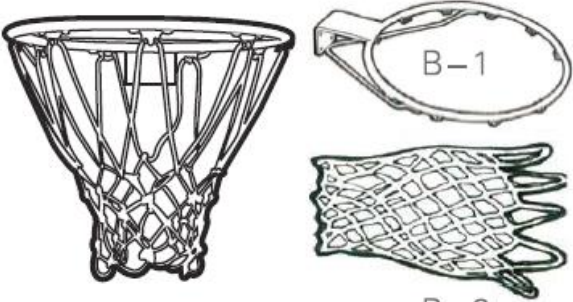
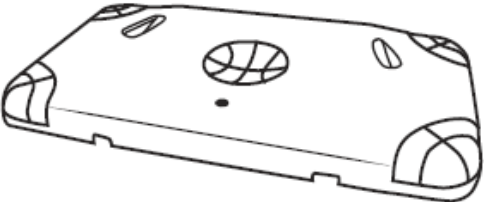











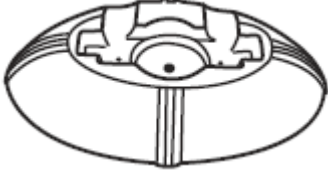

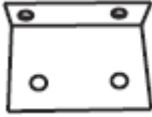



Most injuries are caused by misuse and/or not following instructions. Use caution when using this unit.



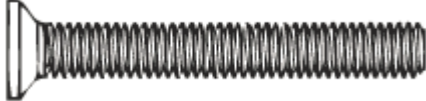

WARNING!

- Manufacturer recommends filling the base with sand, not water. If you choose to use water, ALWAYS check for leaks. Leaking water will lighten the base and cause the system to become unstable and tip over.
- Empty water completely from the base, or add 2 gallons (7.57 liters) of anti-freeze, before the temperature approaches or falls below the freezing point. Freezing water may crack the base and cause leaks. This will result in failure of the system, and could result in serious injury.
- For residential use only! NOT for commercial use! DO NOT use this product for other than its intended purpose. Any commercial, public, or institutional use voids all warranties.

PARTS LIST

<p>A Backboard</p>  <p>x1</p>		<p>B Rim / Net</p>  <p>B-1</p> <p>B-2</p> <p>x1</p>		
<p>C Base</p>  <p>x1</p>	<p>D Bottom pole</p>  <p>x1</p>	<p>E Middle pole</p>  <p>x1</p>	<p>F Top pole</p>  <p>x1</p>	<p>G Horizontal tube</p>  <p>x1</p>
<p>H Upper support arm</p>  <p>x2</p>	<p>I Lower support arm</p>  <p>x2</p>	<p>J Axle</p>  <p>x2</p>	<p>K Desk support arm</p>  <p>x2</p>	

<p>L Wheels</p>  <p>x2</p>	<p>M Twist nut</p>  <p>x1</p>	<p>N Top pole collar</p>  <p>x1</p>	<p>R Pole foot</p>  <p>x1</p>
<p>O Horizontal tube cap</p>  <p>x2</p>	<p>P Brackets</p>  <p>x2</p>	<p>Q Base cap</p>  <p>x1</p>	
<p>Nuts (S)</p>		<p>Washers (T)</p>	
<p>S-1 M6</p>  <p>x2</p>	<p>S-2 M8</p>  <p>x4</p>	<p>T-1 M6</p>  <p>x2</p>	<p>T-2 M8</p>  <p>x9</p>
<p>S-3 M10</p>  <p>x6</p>	<p>S-4 M12</p>  <p>x1</p>	<p>T-3 M10</p>  <p>x13</p>	<p>T-4 M12</p>  <p>x2</p>
<p>Bolts</p>			
<p>1 M8x50mm</p>  <p>x2</p>	<p>2 M8x16mm</p>  <p>x2</p>	<p>3 M10x30mm</p>  <p>x4</p>	<p>4 M6x55mm</p>  <p>x2</p> <hr/> <p>5 M6x20mm</p>  <p>x1</p>

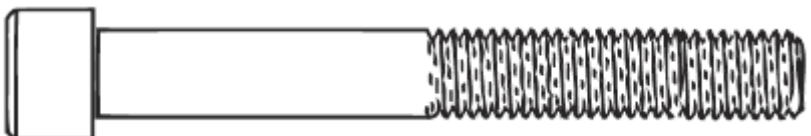
<p>6 M10x85mm</p>  <p>x2</p>	<p>7 M10x16mm</p>  <p>x1</p>
<p>8 M8x90mm</p>  <p>x1</p>	<p>9 M8x90mm</p>  <p>x1</p>
<p>10 M8x80mm</p>  <p>x1</p>	<p>11 M12x130mm</p>  <p>x1</p>

NÁŘADÍ:

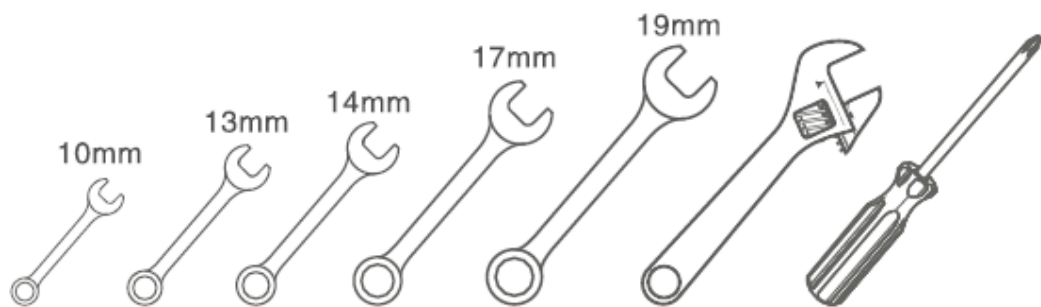

PRECAUTIONS

DO	DO NOT
<p>Keep your face and mouth away from the rim and net during play. If your teeth or face come into contact with the rim and net, serious injury can occur.</p> <p>When adjusting the height or moving the system, keep your fingers and hands away from the moving parts.</p> <p>Ensure the surface beneath the base is flat and free of stones, gravel, or any other debris which may puncture the base. If leakage occurs the system may topple over.</p> <p>Check system before each use for loose fittings, wear and tear or any other signs of instability. Tighten any loose fittings.</p> <p>Keep water and organic material away from the pole. The pole could rust and fall.</p> <p>Once a month check the pole and all metal parts for rust.</p>	<p>Do not hang from the rim.</p> <p>Do not wear jewellery during play, it may become entangled with the net.</p> <p>Do not slide or climb onto the base or pole.</p> <p>Do not leave the system standing upright without having filled the base with water or sand.</p> <p>Do not allow children to adjust the height or move the system.</p> <p>Do not use the system in windy or severe weather conditions. System may tip over. Place system in an area protected from the wind or in an area away from property that may be damaged if the system falls.</p> <p>Do not use near overhead power lines.</p> <p>Do not hang anything off the rim or backboard and do not use the system to lift or hoist anything.</p>

ASSEMBLY

STEP 1



Fill some of water or sand before assembling, it better to be sand.

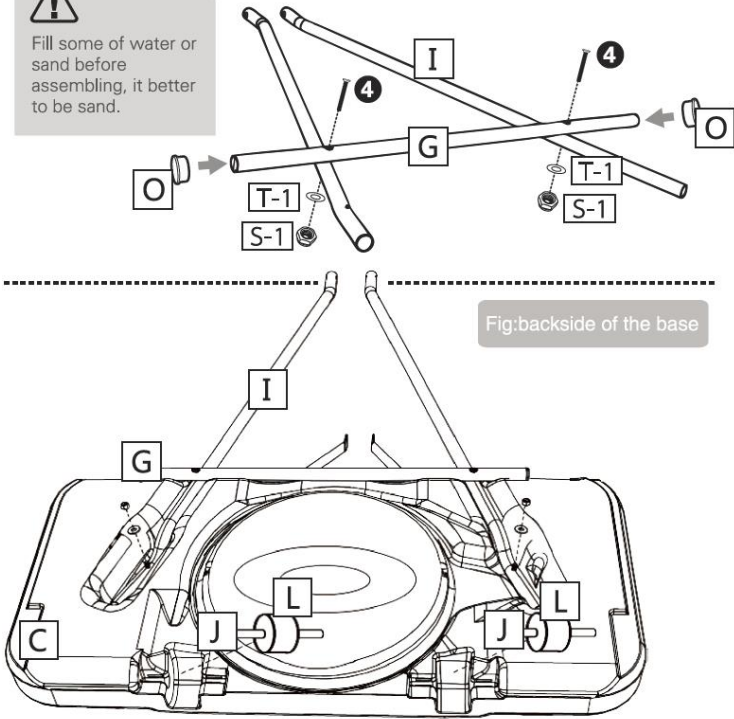
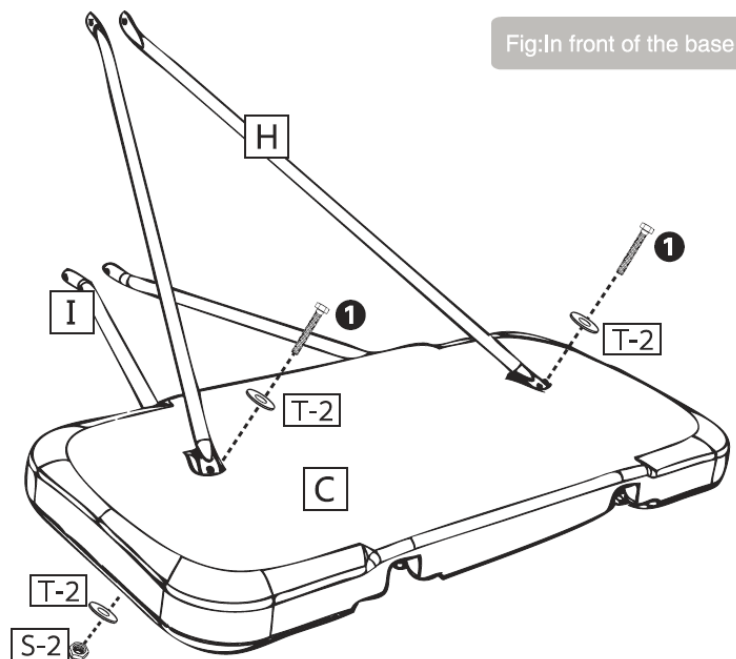

Fig:backside of the base

1. Position horizontal tube (G) into position on lower arms (I) and secure using two bolts (4), washers (T-1) and nuts (S-1).
2. Insert axles (J) into wheels (L), inside them underside the base.
3. Insert tube caps (O) into two sides of horizontal tube (G).

STEP 2

Place support arms (I) and tube (G) into the grooves on the underside of the base (C). Insert bolts (1) through washers (T-2), upper support arms (H) and base, secure into place using the nut (S-2) on the underside.



STEP 3

1. Insert the bottom pole (D) and lower support arms (I) into pole foot (R), secure using two bolts (11, 7) through three washers (T-4, T-3) and one nut (S-4).
2. Attach the bottom pole (D) to the upper support arm (H) using one bolt (8) with two washer (T-2) and one nut (S-2).

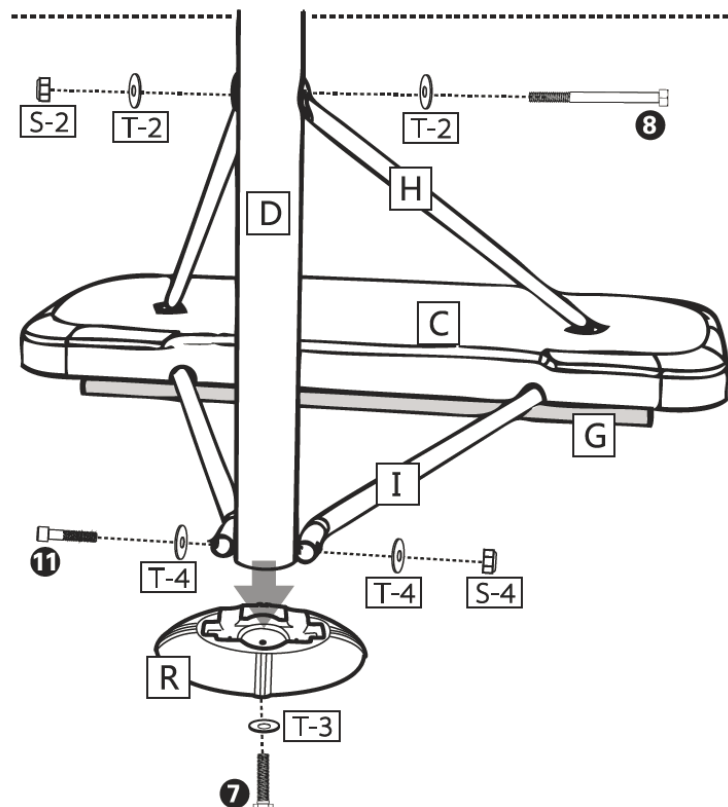

STEP 4

1. Attach the brackets (P) and rim (B) on the backboard with using four bolts (3) through eight washers (T-3) and nuts (S-3).

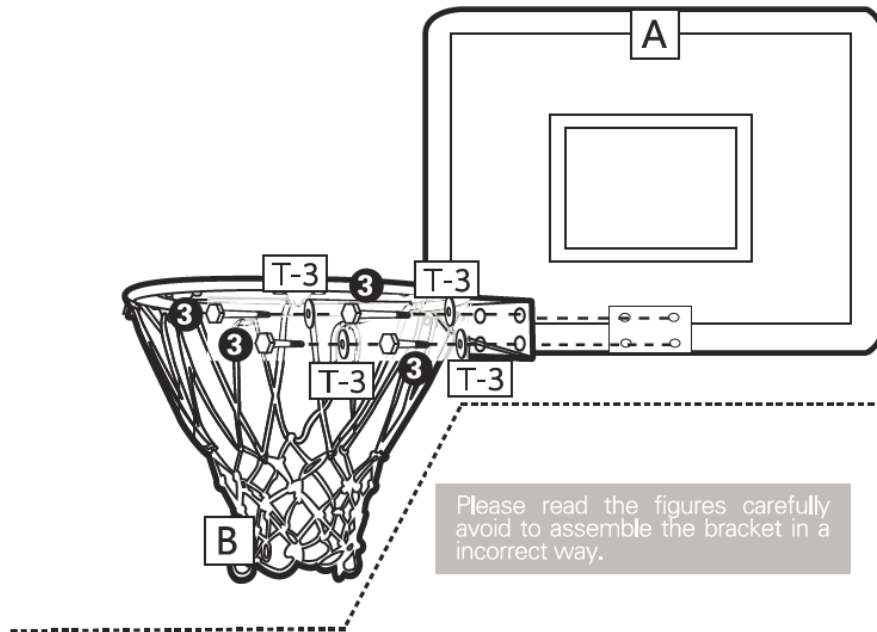

2. Using two bolts (2) through two washers (T-2) to secure desk support arms (K) on the backboard (A).

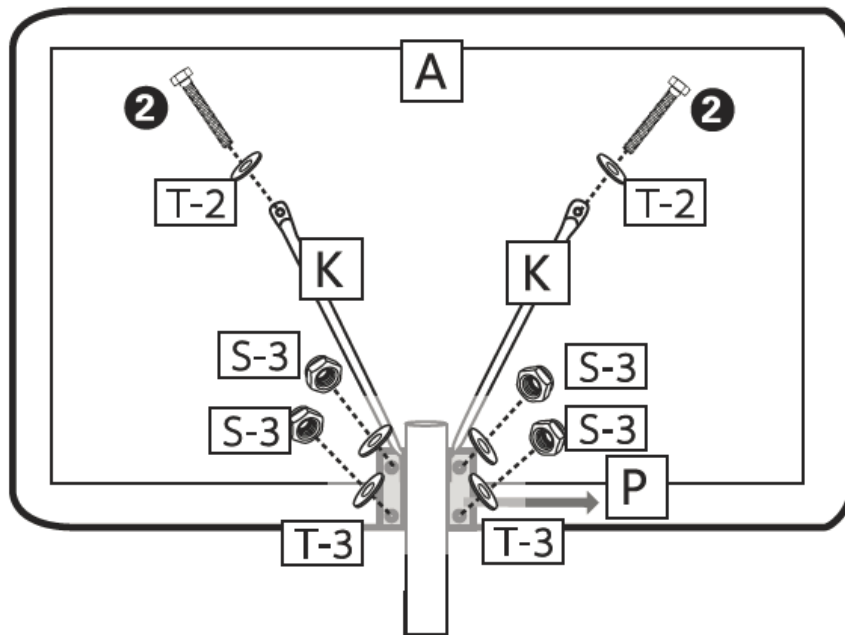

STEP 5

NET AND RIM ASSEMBLY:

Find loops at top edge of net (B-2). Hook one loop over and around center of rim hook (B-1). Pull loop down to secure loop within rim hook. Repeat for remaining net loops.



1. Insert the top pole (F) up inside the middle pole (E) so that it protrudes from the top. Secure the two poles using one bolt (9) and twist nut (M).
2. Attach the top pole (F) and desk support arms (K) with using two bolts (6) through four washers (T-3) and two nuts (S-3).
3. Put the top pole cap (N) onto top pole.

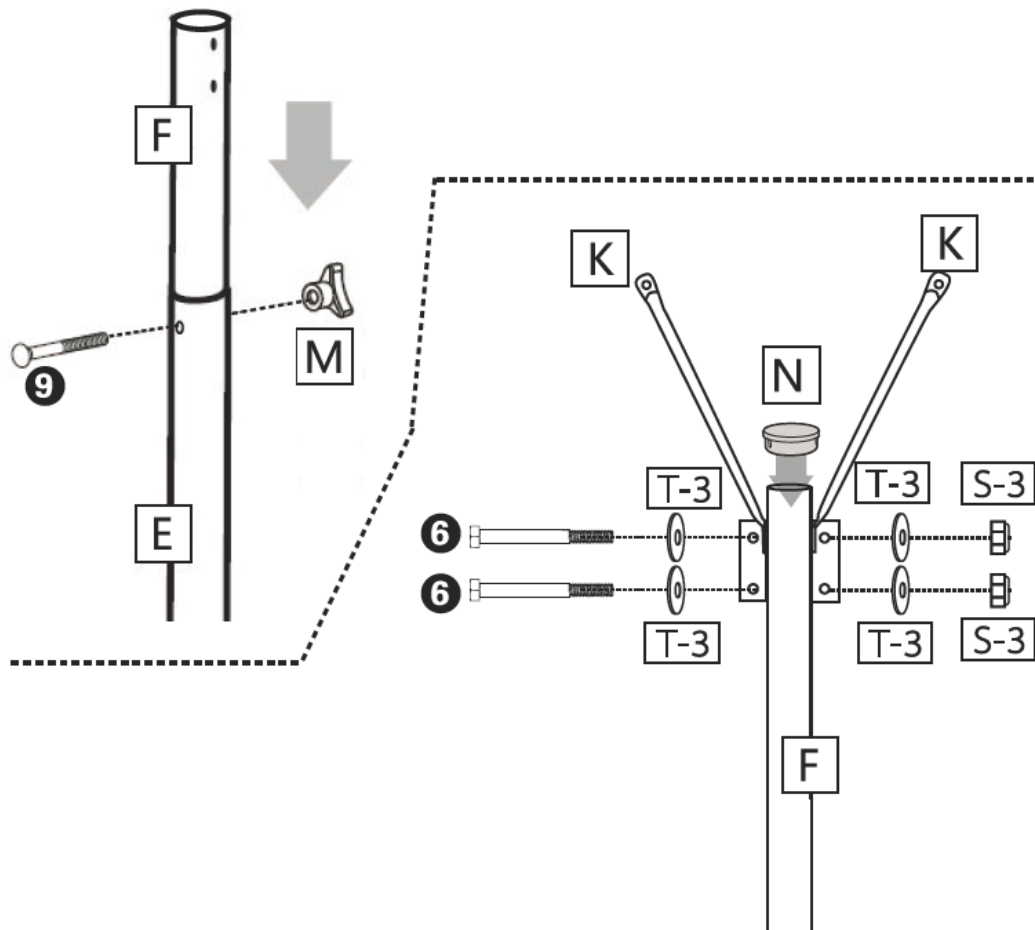

STEP 6

Insert the center pole (E) on the bottom pole (D), secure it using a self-tapping screw (5) and insert one bolt (10) through washer (T-2) and nut (S-2) to make sure the middle pole is always in the right position.

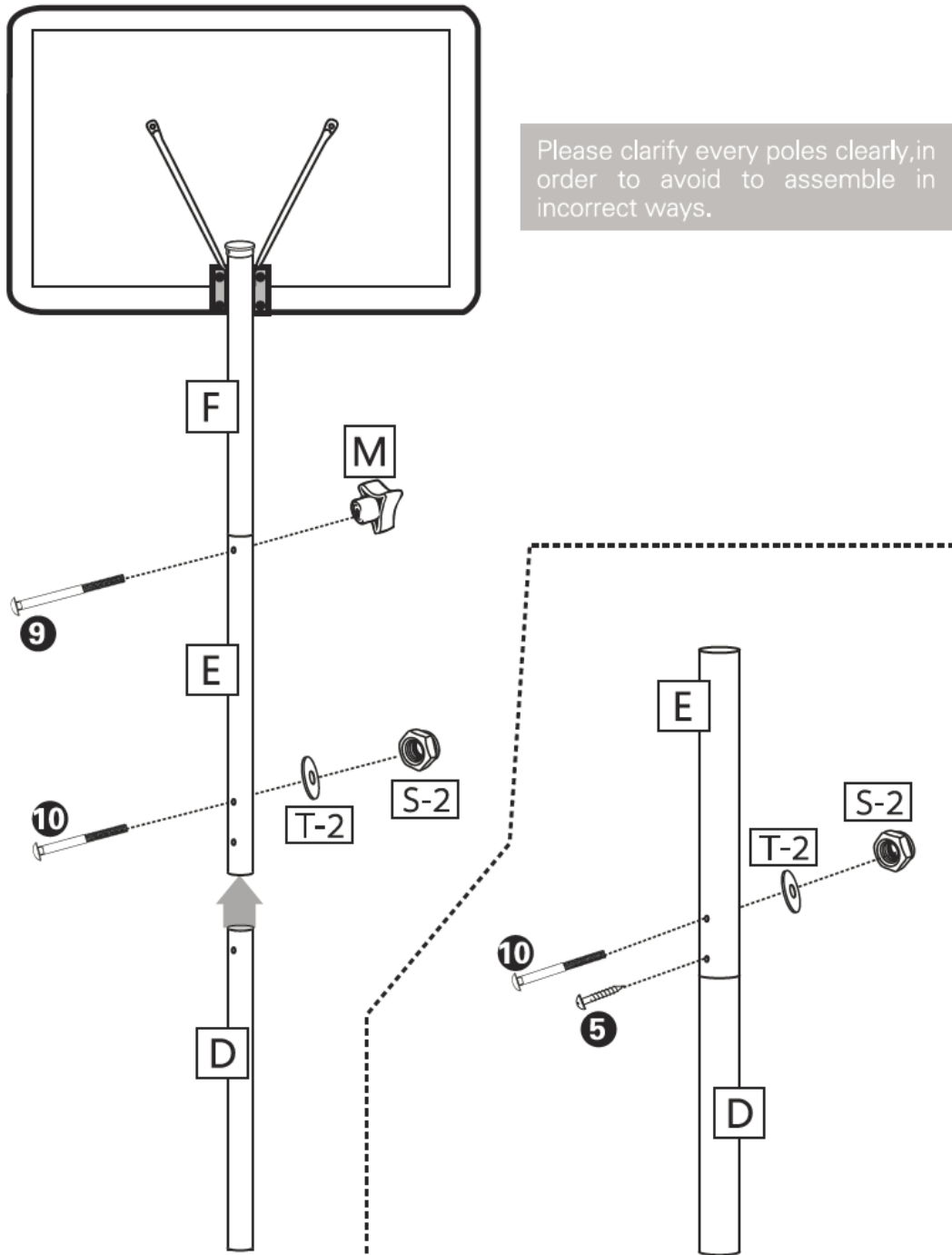

STEP 7

WARNING:

- Two capable adults required for this step.
- NEVER leave system in upright position without proper weight in base or the system will tip over.
- Manufacturer recommends using sand. If using water, see SAFETY INSTRUCTIONS: WARNING.

1. Place base where it will be used. Unscrew and remove base cap.
2. First adult: Tip base up at a 45° angle.
3. Second adult: Carefully pour sand into base.
4. Allow sand to slide into lower end of base near the wheels. Gradually lower base as sand is poured to ensure sand fills entire base. Once full, replace cap.
5. If filling with water, DO NOT tip base up.

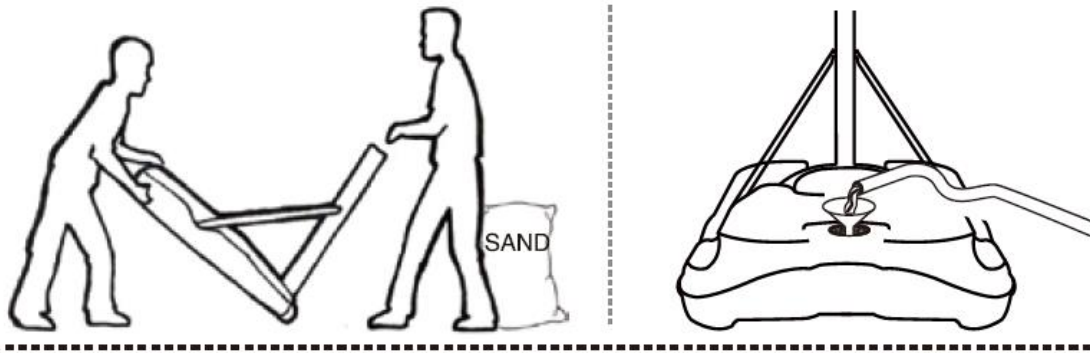

TRANSPORT

1. Adjust backboard to lowest position.
2. While holding pole and lifting base, carefully lean system forward until wheels touch ground.
3. While holding pole and base, roll system to desired location.
4. Stand pole upright and set base flat on ground.
5. ALWAYS check to make sure system is stable in new location.

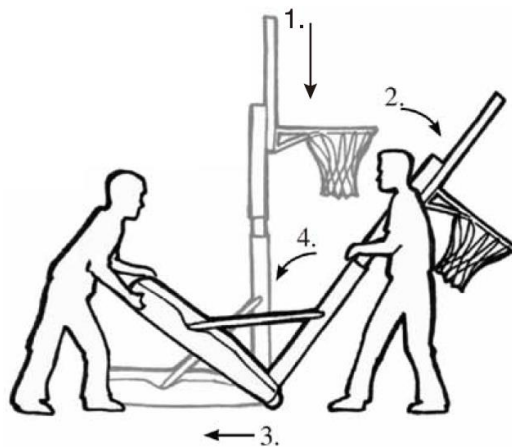

TERMS AND CONDITIONS OF WARRANTY, WARRANTY CLAIMS

General Conditions of Warranty and Definition of Terms

All Warranty Conditions stated hereunder determine Warranty Coverage and Warranty Claim Procedure. Conditions of Warranty and Warranty Claims are governed by Act No. 40/1964 Coll. Civil Code, Act No. 513/1991 Coll., Commercial Code, and Act No. 634/1992 Coll., Consumer Protection Act, as amended, also in cases that are not specified by these Warranty rules.

The seller is SEVEN SPORT s.r.o. with its registered office in Borivojova Street 35/878, Prague 13000, Company Registration Number: 26847264, registered in the Trade Register at Regional Court in Prague, Section C, Insert No. 116888.

According to valid legal regulations it depends whether the Buyer is the End Customer or not.

“The Buyer who is the End Customer” or simply the “End Customer” is the legal entity that does not conclude and execute the Contract in order to run or promote his own trade or business activities.

“The Buyer who is not the End Customer” is a Businessman that buys Goods or uses services for the purpose of using the Goods or services for his own business activities. The Buyer conforms to the General Purchase Agreement and business conditions to the extent specified in the Commercial Code.

These Conditions of Warranty and Warranty Claims are an integral part of every Purchase Agreement made between the Seller and the Buyer. All Warranty Conditions are valid and binding, unless otherwise specified in the Purchase Agreement, in the Amendment to this Contract or in another written agreement.

Warranty Conditions

Warranty Period

The Seller provides the Buyer a 24 months Warranty for Goods Quality, unless otherwise specified in the Certificate of Warranty, Invoice, Bill of Delivery or other documents related to the Goods. The legal warranty period provided to the Consumer is not affected.

By the Warranty for Goods Quality, the Seller guarantees that the delivered Goods shall be, for a certain period of time, suitable for regular or contracted use, and that the Goods shall maintain its regular or contracted features.

The Warranty does not cover defects resulting from:

User's fault, i.e. product damage caused by unqualified repair work, improper assembly, insufficient insertion of seat post into frame, insufficient tightening of pedals and cranks

Improper maintenance

Mechanical damages

Regular use (e.g. wearing out of rubber and plastic parts, joints etc.)

Unavoidable event, natural disaster

Adjustments made by unqualified person

Improper maintenance, improper placement, damages caused by low or high temperature, water, inappropriate pressure, shocks, intentional changes in design or construction etc.

Warranty Claim Procedure

The Buyer is obliged to check the Goods delivered by the Seller immediately after taking the responsibility for the Goods and its damages, i.e. immediately after its delivery. The Buyer must check the Goods so that he discovers all the defects that can be discovered by such check.

When making a Warranty Claim the Buyer is obliged, on request of the Seller, to prove the purchase and validity of the claim by the Invoice or Bill of Delivery that includes the product's serial number, or eventually by the documents without the serial number. If the Buyer does not prove the validity of the Warranty Claim by these documents, the Seller has the right to reject the Warranty Claim.

If the Buyer gives notice of a defect that is not covered by the Warranty (e.g. in the case that the Warranty Conditions were not fulfilled or in the case of reporting the defect by mistake etc.), the Seller is eligible to require a compensation for all the costs arising from the repair. The cost shall be calculated according to the valid price list of services and transport costs.

If the Seller finds out (by testing) that the product is not damaged, the Warranty Claim is not accepted. The Seller reserves the right to claim a compensation for costs arising from the false Warranty Claim.

In case the Buyer makes a claim about the Goods that is legally covered by the Warranty provided by the Seller, the Seller shall fix the reported defects by means of repair or by the exchange of the damaged part or product for a new one. Based on the agreement of the Buyer, the Seller has the right to exchange the defected Goods for a fully compatible Goods of the same or better technical characteristics. The Seller is entitled to choose the form of the Warranty Claim Procedures described in this paragraph.

The Seller shall settle the Warranty Claim within 30 days after the delivery of the defective Goods, unless a longer period has been agreed upon. The day when the repaired or exchanged Goods is handed over to the Buyer is considered to be the day of the Warranty Claim settlement. When the Seller is not able to settle the Warranty Claim within the agreed period due to the specific nature of the Goods defect, he and the Buyer shall make an agreement about an alternative solution. In case such agreement is not made, the Seller is obliged to provide the Buyer with a financial compensation in the form of a refund.



SEVEN SPORT s.r.o.

Registered Office:	Borivojova 35/878, 130 00 Praha 3, Czech Republic
Headquarters:	Delnicka 957, 749 01 Vitkov, Czech Republic
Warranty & Service Centre:	Cermenska 486, 749 01 Vitkov, Czech Republic
CRN:	26847264
VAT ID:	CZ26847264
Phone:	+420 556 300 970
E-mail:	eshop@insportline.cz reklamace@insportline.cz servis@insportline.cz
Web:	www.insportline.cz

SK

INSPORTLIN s.r.o.

Headquarters, Warranty & Service centre:	Elektricka 6471, 911 01 Trencin, Slovakia
CRN: 36311723	
VAT ID: SK2020177082	
Phone:	+421(0)326 526 701
E-mail:	objednavky@insportline.sk reklamacie@insportline.sk servis@insportline.sk
Web:	www.insportline.sk

Date of Sale:

Stamp and Signature of Seller: