

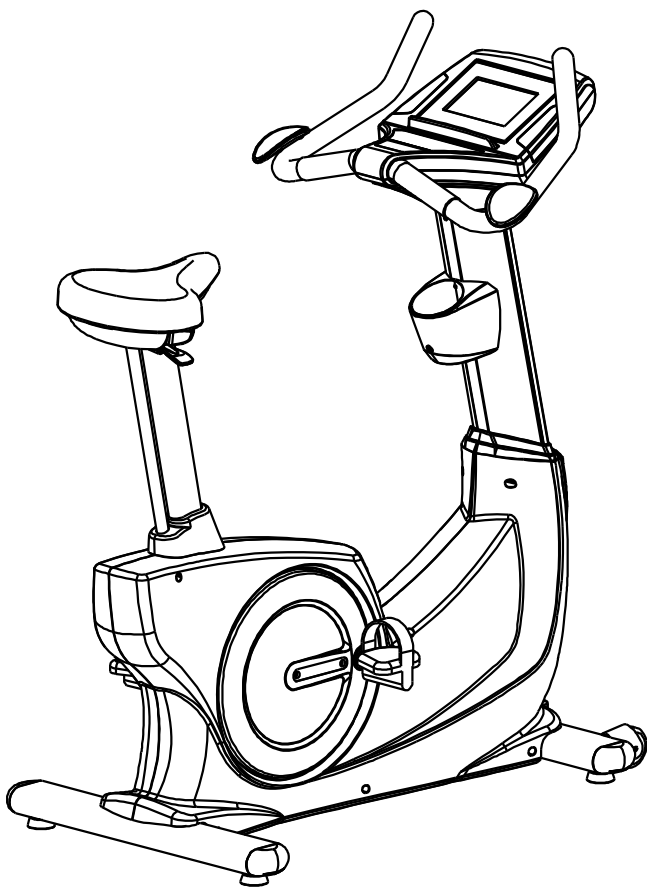

User manual-EN

IN 896 Up right bike inSPORTline SEG 7020



Exercise can present a health risk. Consult a physician before beginning any exercise program with this equipment.

If you feel faint or dizzy, immediately discontinue use of this equipment. Serious bodily injury can occur if this equipment is not assembled and used correctly. Serious bodily injury can also occur if all instructions are not followed.

Keep others and pets away from equipment when in use. Always make sure all bolts and nuts are tightened prior to each use. Follow all safety instructions in this manual.

CAUTION:

Weight on this product should not exceed 181 kgs/ 400 lbs

Product May Vary Slightly Different From Picture

MADE IN TAIWAN



SAFETY INSTRUCTIONS

WARNING: To reduce the risk of serious injury, read the following Safety Instructions before using the Upright Bike.

1. Read all warnings posted on the **Upright Bike**.
2. Read this Owner's Manual and follow it carefully before using the **Upright Bike**. Make sure that it is properly assembled and tightened before use.
3. We recommend that two people be available for assembly of this product.
4. Keep children away from the **Upright Bike**. Do not allow children to use or play on the **Upright Bike**. Keep children and pets away from the **Upright Bike** when it is in use.
5. It is recommended that you place this exercise equipment on an equipment mat.
6. Set up and operate the **Upright Bike** on a solid level surface. Do not position the **Upright Bike** on loose rugs or uneven surfaces.
7. Inspect the **Upright Bike** for worn or loose components prior to use.
8. Tighten/replace any loose or worn components prior to using the **Upright Bike**.
9. Consult a physician prior to commencing an exercise program. If, at any time during exercise, you feel faint, dizzy, or experience pain, stop and consult your physician.
10. Follow your physician's recommendations in developing your own personal fitness program.
11. Always choose the workout which best fits your physical strength and flexibility level. Know your limits and train within them. Always use common sense when exercising.
12. Before using this product, please consult your personal physician for a complete physical examination.
13. Do not wear loose or dangling clothing while using the **Upright Bike**.
14. Never exercise in bare feet or socks; always wear correct footwear, such as running, walking, or cross-training shoes.
15. Be careful to maintain your balance while using, mounting, dismounting, or assembling the **Upright Bike**, loss of balance may result in a fall and serious bodily injury.
16. Keep both feet firmly and securely on the Foot Pedals while exercising.
17. The **Upright Bike** should not be used by persons weighing over 400 pounds /181 kgs.
18. The **Upright Bike** should be used by only one person at a time.
19. Maintenance: Replace the defective components immediately and/or keep the equipment out of use until repair the equipment completely.
20. The **Upright Bike** is well-suited to studio use (Class S.)
21. Make sure that adequate space is available for access to and passage around the **Upright Bike**; keep at least a distance of 1 meter from any obstruction object while using the machine.

WARNING: Before starting any exercise or conditioning program you should consult with your personal physician to see if you require a complete physical exam. This is especially important if you are over the age of 35, have never exercised before, are pregnant, or suffer from any illness. **READ AND FOLLOW THE SAFETY PRECAUTIONS. FAILURE TO FOLLOW THESE INSTRUCTIONS CAN RESULT IN SERIOUS BODILY INJURY.**

BEFORE YOU BEGIN

Thank you for choosing the self-powered **UPRIGHT BIKE**. We take great pride in producing this quality product and hope it will provide many hours of quality exercise to make you feel better, look better and enjoy life to its fullest.

Yes, it's a proven fact that a regular exercise program can improve your physical and mental health.

Too often, our busy lifestyles limit our time and opportunity to exercise. The **UPRIGHT BIKE** provides a convenient and simple method to begin your assault on getting your body in shape and achieving a happier and healthier lifestyle.

Before reading further, please review the drawing below and familiarize yourself with the parts that are labeled. Read this manual carefully before using the **UPRIGHT BIKE**.

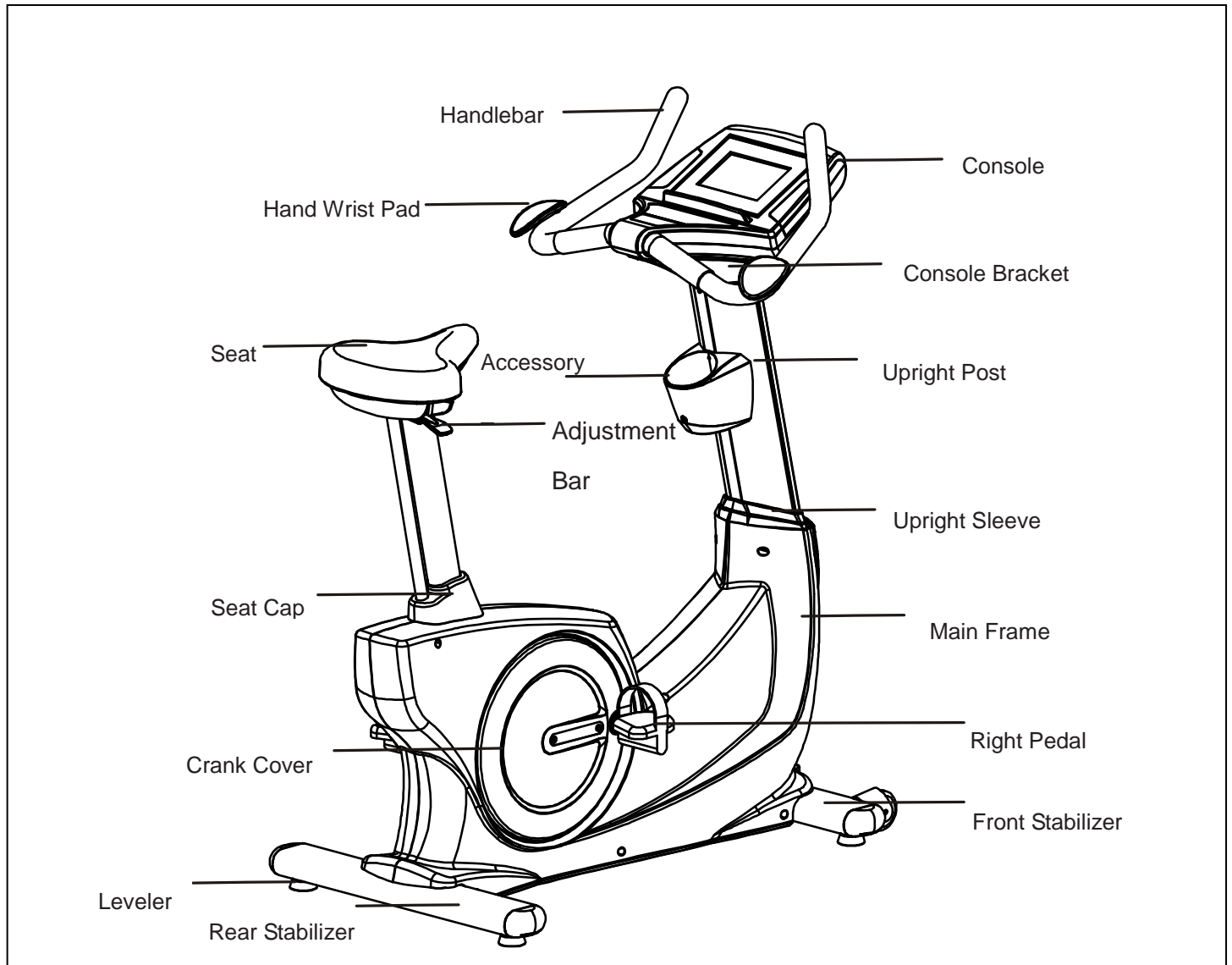

THE FOLLOWING TOOLS ARE INCLUDED FOR ASSEMBLY:

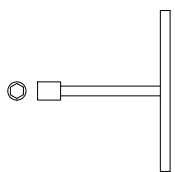

T-HAND SOCKET WRENCH (17MM)



COMBINATION WRENCH



ALLEN WRENCH (M5, M6)



SOCKET WRENCH



PHILLIPS SCREWDRIVER (6mm)

HARDWARE IDENTIFICATION CHART

This chart is provided to help identify the hardware used in the assembly process. Place the washers, the end of the bolts, or screws on the circles to check for the correct diameter. Use the small scale to check the length of the bolts and screws.

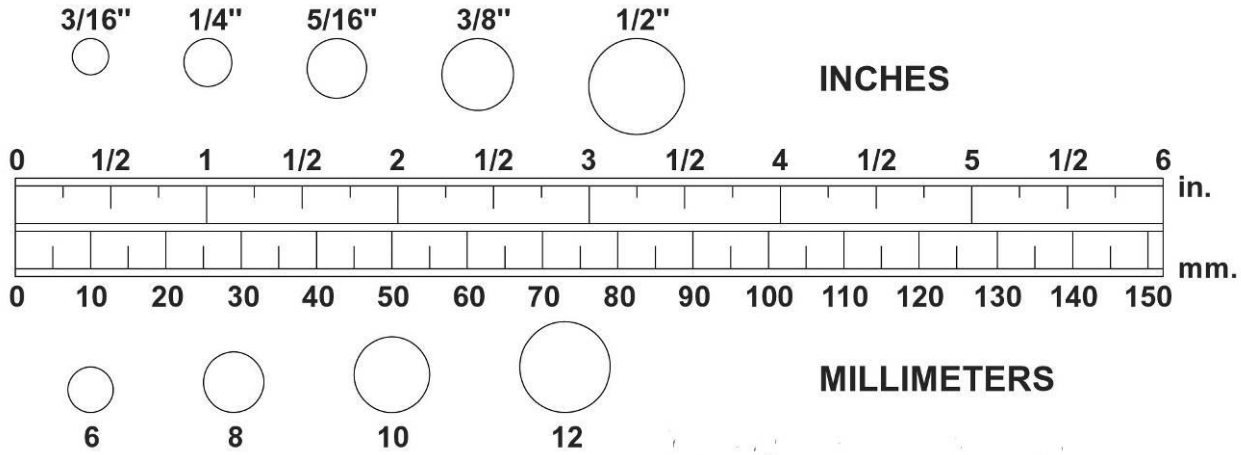

NOTICE: The length of all bolts and screws except those with flat heads is measured from

below the head to the end of the bolt or screw. Flat head bolts and screws are measured from the top of the head to the end of the bolt or screw.



After unpacking the unit, open the hardware bag and make sure that you have all the following items. Some hardware may be already attached to the part.

	Part No. and Description	Qty
	78 Lock Washer (M8)	4
	73 Washer (8x38x2.0t)	4
	83 Screw, Round Head (M5xp0.8x15mm)	10
	84 Screw, Round Head (M5xp0.8x50mm)	2
	88 Bolt, Button Head (M6xp1.0x12mm)	2
	97 Bolt, Hex Head (M8xp1.25x65mm)	4

	99 Bolt, Hex Head (M10xp1.5x50mm)	2
---	-----------------------------------	---

ASSEMBLE INSTRUCTIONS

Place all parts from the box in a cleared area and position them on the floor in front of you. Remove all packing materials from your area and place them back into the box. Do not dispose of the packing materials until assembly is completed. Read each step carefully before beginning.

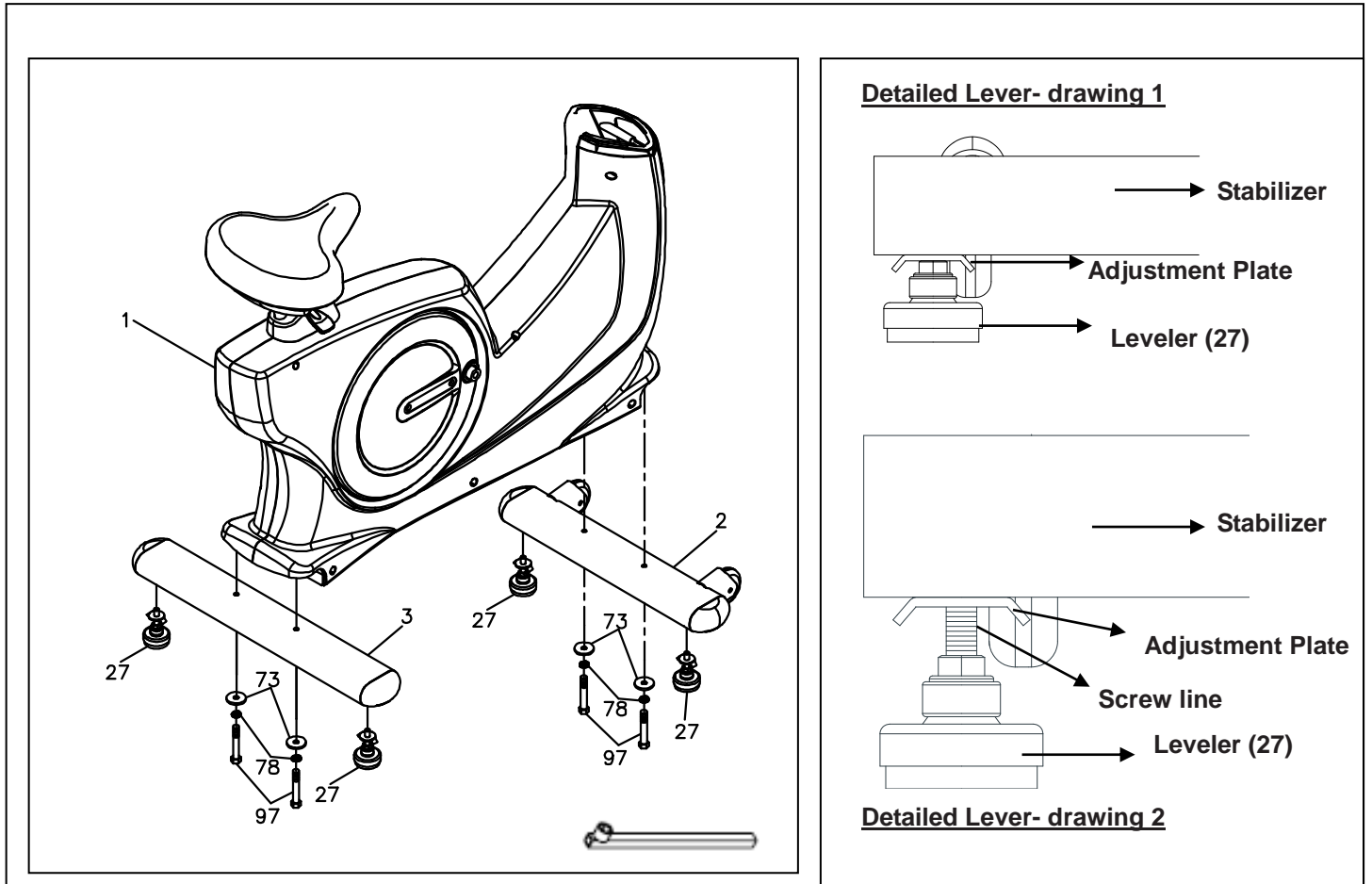

STEP 1



- ◆ Attach the **Leveler (27)** to the **Front Stabilizer (2)** and the **Rear Stabilizer (3.)**
- ◆ Be sure to tighten the **Leveler (27)** securely against the **Stabilizers (2, 3)** until screw lines are eliminated as the **drawing 1** shown.

STEP 2

Attach the **Front Stabilizer (2)** and the **Rear Stabilizer (3)** onto the **Main Frame (1)** and secure with the **Washer (8x38x2.0t)(73)**, the **Lock Washer**

LEVELING: After placing the bike in the intended location for use, check the stability of the bike. If the bike is not level, reviewing the following direction:

Loosen the Leveler (27) to make the Adjustment Plate become less tight.

Adjust the Leveler (27) for leveling.

Tighten the Adjustment Plate securely against the Stabilizer to lock the Leveler (27) in stable position as the drawing 2 shown.

(M8)(78) and the **Bolt, Hex Head (M8xp1.25x65mm)(97)** by using socket wrench as the main assembling drawing shows.

◆ If the bike is not level, review the **LEVELING NOTE** on the right side to level the **Levelers (27.)**

ASSEMBLE INSTRUCTIONS

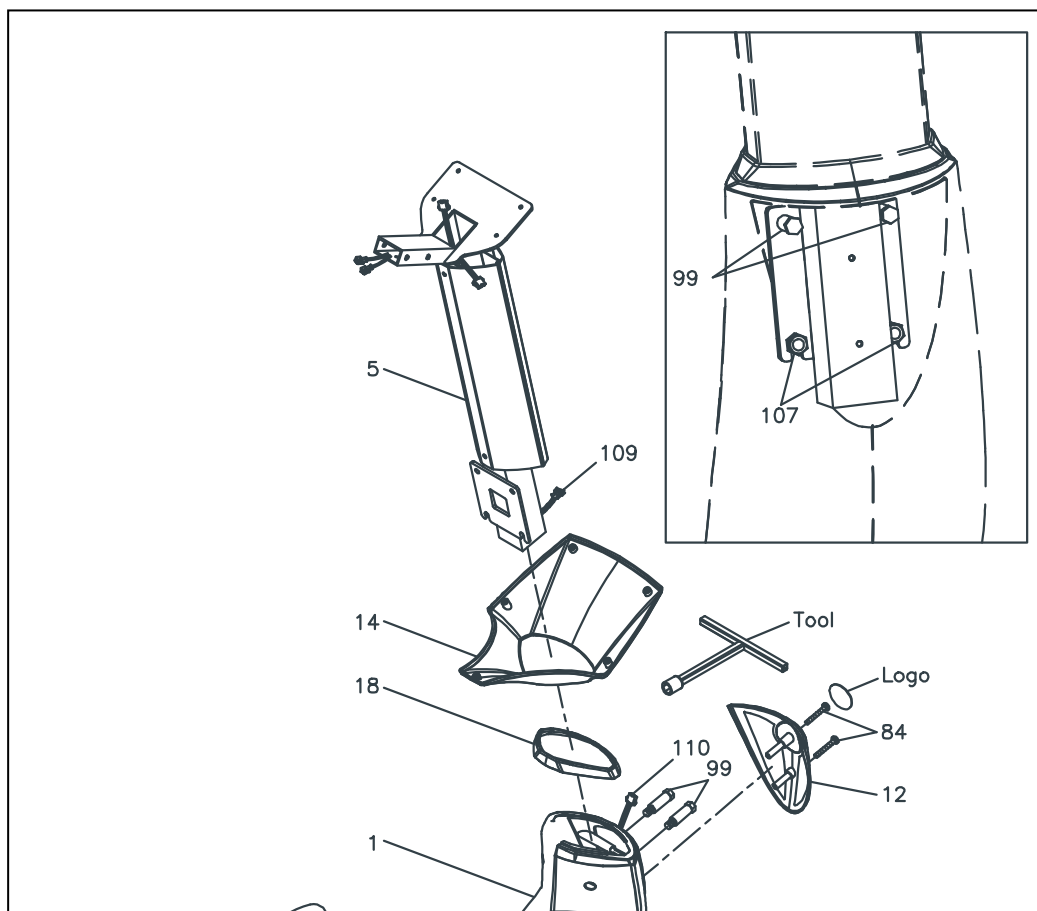

STEP 3

Slide the **Console Bracket (14)** and the **Upright Sleeve (18)** onto the **Upright Post (5.)**

- ◆ Make sure the
- ◆ Be careful not

STEP 4

- a. Make sure 2 pc) as the illustration shown on the tc
- b. Insert the **Uprig x50mm)(99)** by using the **T-HEAD SOCKET WRENCH (17MM)** as shown.

STEP 5

- a. Connect the **Middle Connection Wire (109)** to the **Lower Connection Wire (110.)**
- b. Attach the **Front Decorating Upright Cover (12)** onto the front of the **Main Frame (1)** with the **Screw, Round Head (M5xp0.8x50mm)(84.)**

- c. Paste a Logo Sticker on the surface of the **Front Decorating Upright Cover (12.)**
 - ◆ A logo sticker is included in the hardware box.
- d. Slide the **Upright Sleeve (18)** down to cover the open area of the **Main Frame (1.)**

ASSEMBLE INSTRUCTIONS

STEP 6

- ◆ Connect the **Lower Pulse Sensor Wire (113)** to the **Middle Pulse Sensor Wire (112B.)**
- ◆ Remove the **Lock Washer (M8)(78)** and **Bolt, Button Head (M8x1.25x16mm) (90)** from the **Upright Post (5).**
- ◆ Insert the **Handlebar (6)** into the **Upright Post (5)** and secure with the **Lock Washer (M8)(78)** and **Bolt, Button Head (M8x1.25x16mm)(90)** on each side as the drawing shown.

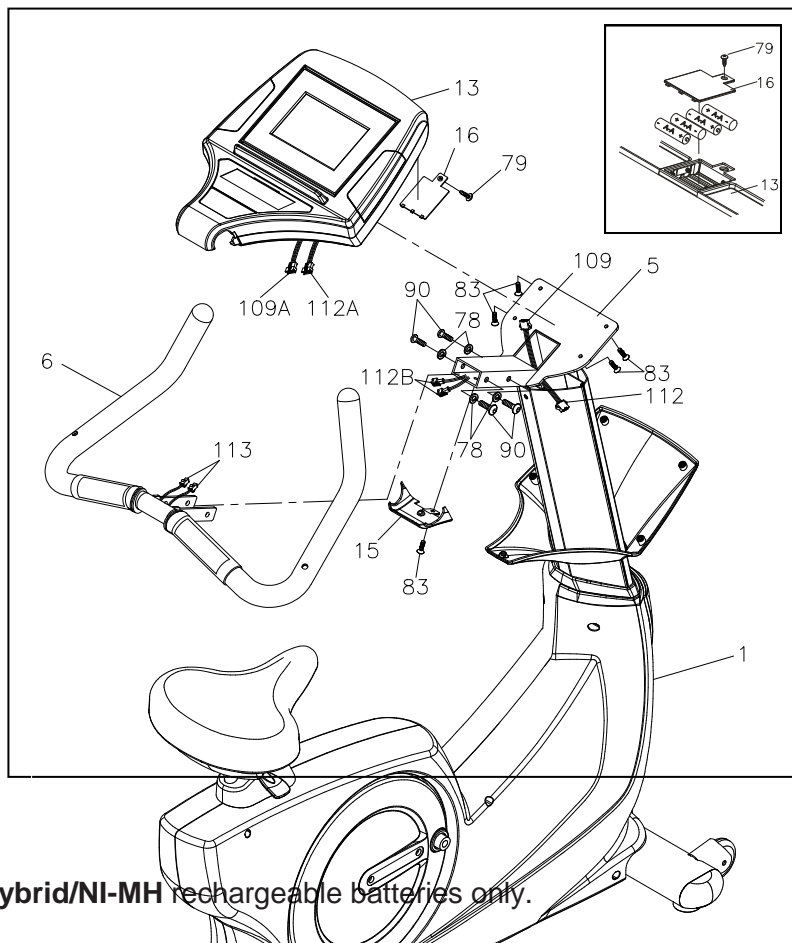

STEP 7

- a. Loosen the **Screw (M3x10mm)(79)** at the bottom on the console by using the combination wrench to open the **Battery Door (16.)**
- b. The **Console (13)** operates with FOUR AA rechargeable batteries, four batteries are included in the hardware box.
- ◆ The machine is suitable for **Nickel-Metal Hybrid/NI-MH** rechargeable batteries only.



NOTE: To prevent from any damages, general batteries and other type of batteries are not allowed.

- c. Install rechargeable batteries into the console.

STEP 8

Attach the **Battery Door (16)** onto the back of the **Console (13)** with the **Screw (M3x10mm)(79.)**

STEP 9

- a. Connect the **Middle Pulse Sensor Wire (112A)** to the **Middle Pulse Sensor Wire (112.)**
- b. Connect the **Middle Connection Wire (109A)** to the **Middle Connection Wire (109.)**
- ◆ Note the number of wire pin should be the same for both wires to connect with as the illustration shown on the right.

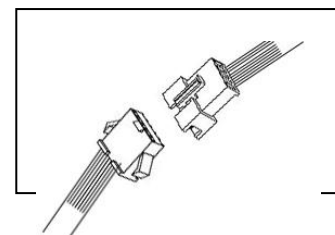

STEP 10

Place the **Console (13)** onto the **Upright Post (5)** and secure with the **Screw, Round Head (M5x0.8x15mm)(83.)**

STEP 11

Attach the **Console Lower Case (15)** to the **Console (13)** and secure with the **Screw, Round Head (M5xp0.8x15mm)(83.)**

ASSEMBLE INSTRUCTIONS

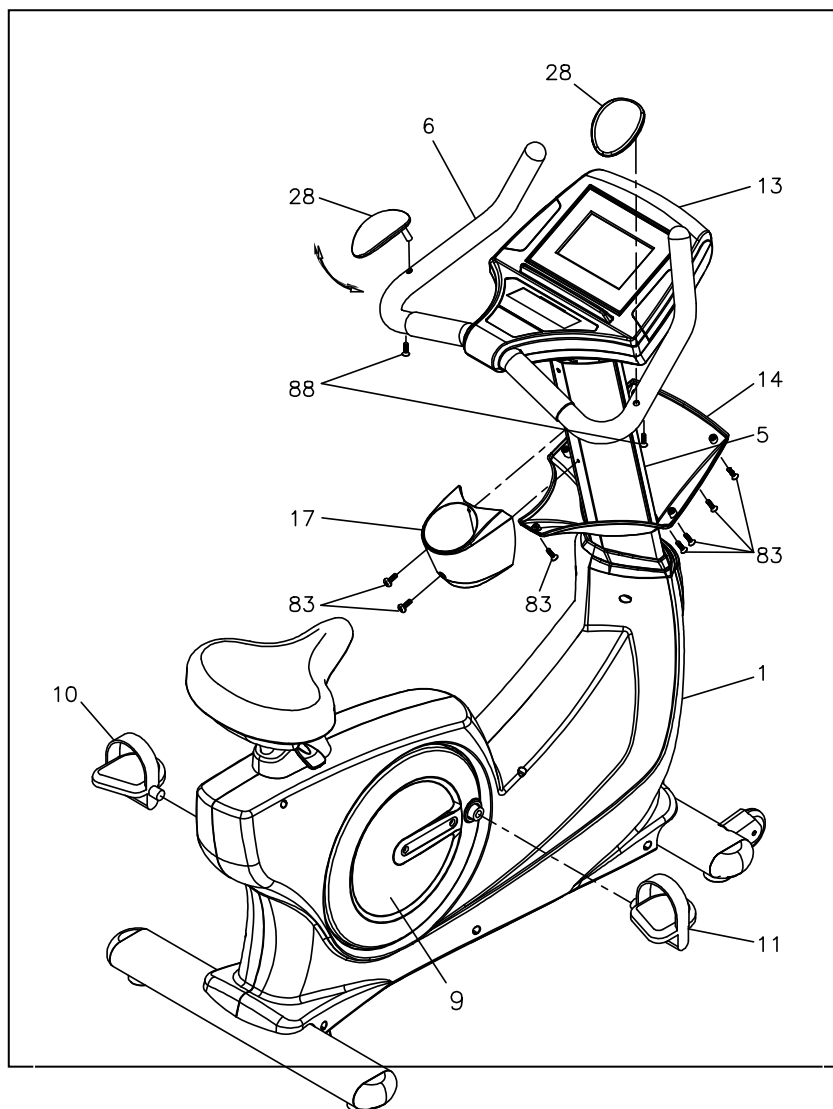

STEP 12

Slide the **Console Bracket (14)** onto the **Console (13)** and secure with the **Screw, Round Head (M5xp0.8x15mm)(83.)**

STEP 13

- Place the **Hand Wrist Pad (28)** onto the **Handlebar (6.)**
- Swing the **Hand Wrist Pad (28)** to the most suitable position.
- Secure it with the **Bolt, Button Head (M6xp1.0x12mm)(88.)**

STEP 14

- Remove the **Screw, Round Head (M5xp0.8x15mm)(83)** from the **Upright Post(5)**.
- Attach the **Accessory Tray (17)** onto the **Upright Post (5)** and secure with the **Screw, Round Head (M5xp0.8x15mm)(83.)**

STEP 15

Thread the **Right Pedal (11)** clockwise onto the **Right Crank** located inside the **Right Crank Cover (9)** as shown. Tighten the pedal securely. Repeat the same procedure to thread and tighten the **Left Pedal (10)** counter-clockwise onto the **Left Crank** as shown.

OPERATIONAL INSTRUCTIONS

A. CONSOLE ANGLE ADJUSTMENT

To get the best angle, user could press the area A or B with the personal need.

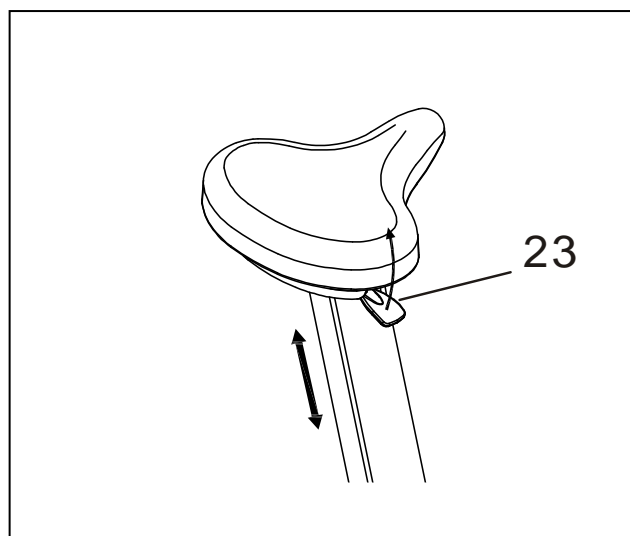
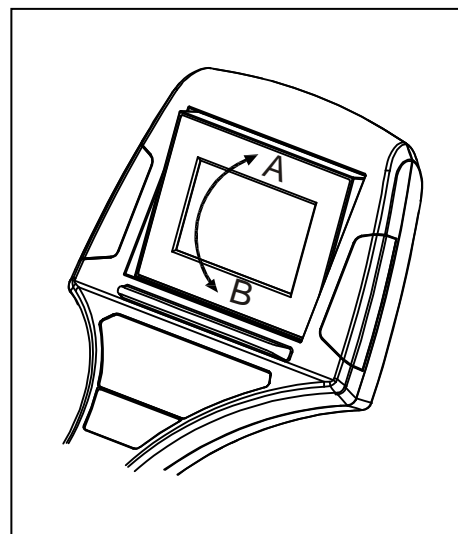

B. SEAT POST ADJUSTMENT

USER CAN ADJUST THE SEAT HEIGHT WHILE BE SEATED

- ◆ While be seated, pull the **Adjustment Bar (23)** up to adjust the seat height.
- ◆ Seat downward to lower the seat height or slight move the body upward to raise the seat height.
- ◆ Once adjusting to the proper position, release the **Adjustment Bar (23)** until hearing the “click” sound.

C. HOW TO TOW THE UPRIGHT BIKE SAFELY

Hold the **Rear Stabilizer (3)** up with two hands and tow the upright bike to the desired place carefully.

- ◆ Make sure the floor is level while towing the upright bike.

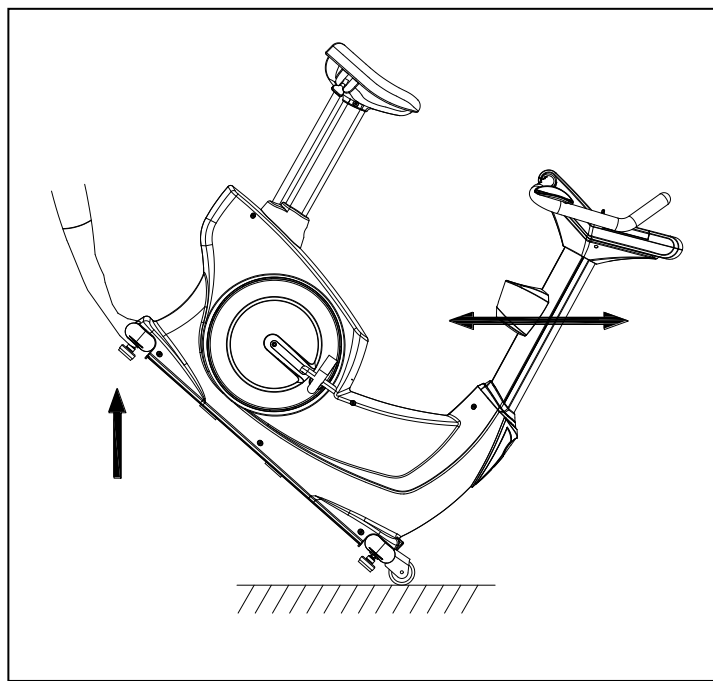

OPERATIONAL INSTRUCTION

HOW TO INSTALL AND REPLACE BATTERIES:

a. **Take off the Console Bracket (14):**

Loosen the **Screw, Round Head (M5xp0.8x15mm)(83)** at the bottom on the **Console Bracket (14.)**

b. **Open the Battery Door (16):**

Loosen the **Screw (M3x10mm)(79)** at the bottom on the **Console (13)** by using the combination wrench to open the **Battery Door (16.)**

c. **Install and replace batteries:**

The **Console (13)** operates with four AA rechargeable batteries, four batteries included into the hardware box.

- ◆ The machine is suitable for **Nickel-Metal Hybrid/NI-MH** rechargeable batteries only.



NOTE: To prevent from any damages, general batteries and other type of batteries are not allowed.

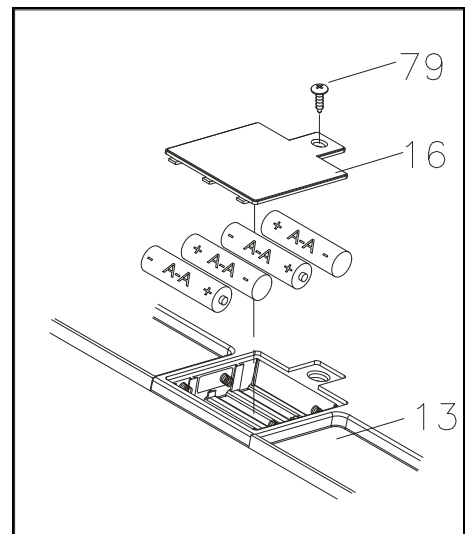
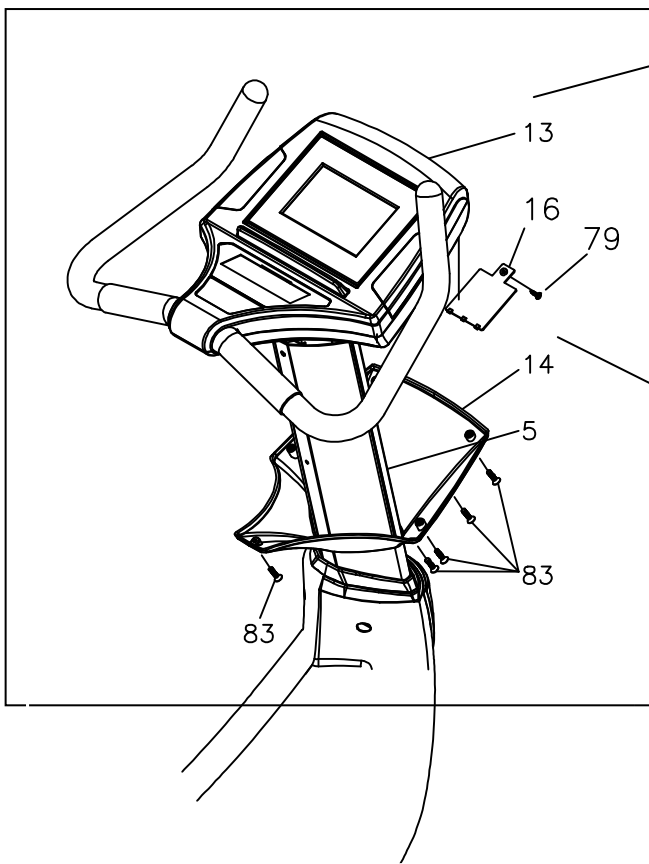

CONSOLE OVERVIEW

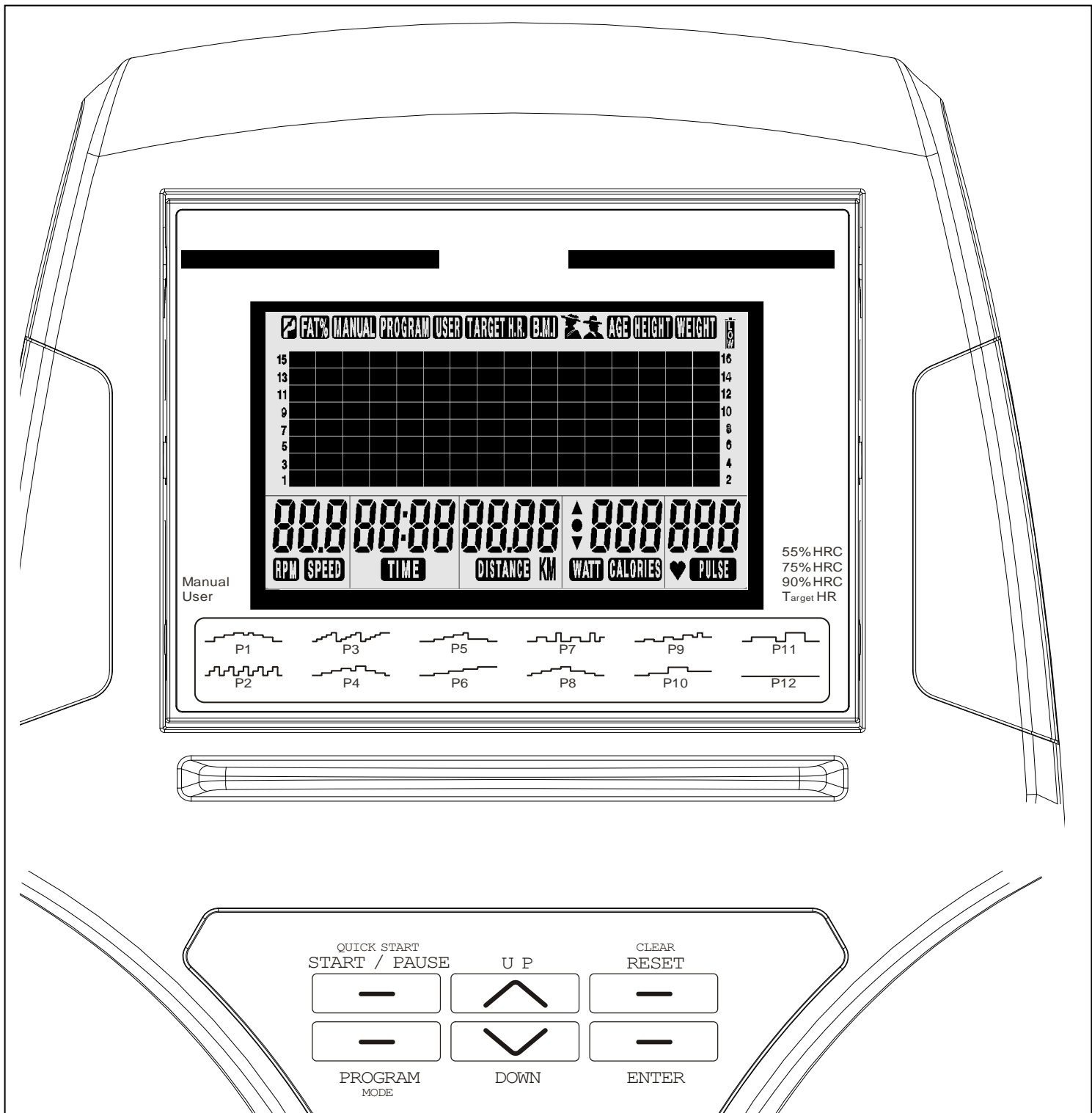

- ◆ The console display may vary slightly from the actual console display, the above console overview is for reference only
- ◆ The console has metric and imperial system difference due to the usage of the different countries - Distance: 0.0~99.9 Km/Mile

COMPUTER OPERATION

POWER ON:

- a. Pedaling to activate the console.
- b. The activated LCD console lights up along with a long beep sound. LCD diagram appears as below:

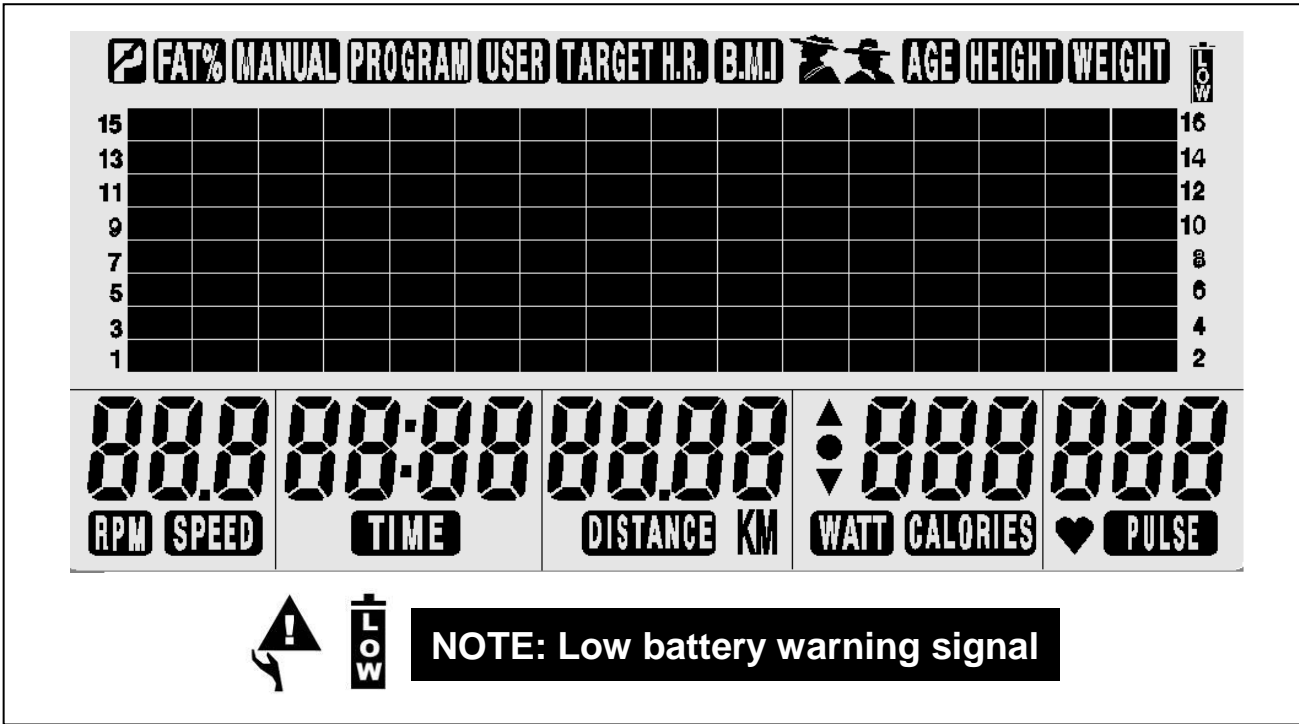

- c. Enter into the initial setting mode after around two seconds as below:

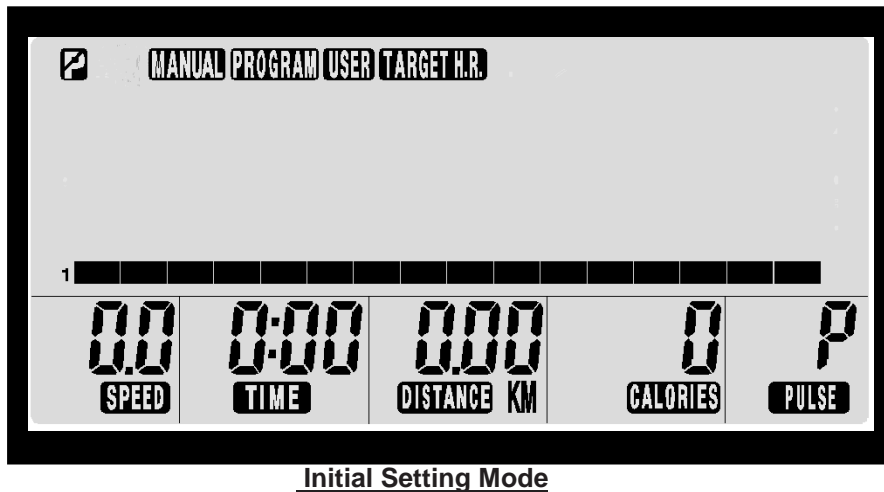





POWER OFF:

The console would automatically shut off after 30 seconds of inactivity.



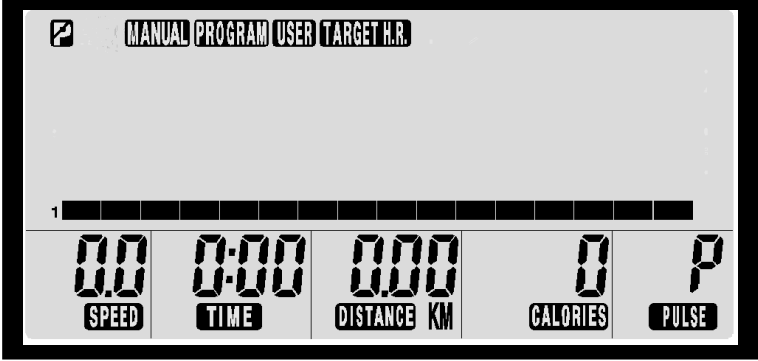





NOTE: the console would shut down any seconds if rechargeable batteries run out of power.

● **FUNCTION BUTTONS:**

Button Name	Function Description
 <p>PROGRAM MODE</p>	<p>Press the button to select the desired mode – MANUAL , PROGRAM , USER , TARGET H.R. as shown:</p>  <p>◆ Press the ENTER to confirm and enter the function value setting.</p>
 <p>ENTER</p>	<p>**The button is equipped with TWO operating methods**</p> <ol style="list-style-type: none"> Press the button to confirm and enter the selected mode (MANUAL , PROGRAM , USER , TARGET H.R. .) Press to select the function value displays of TIME , DISTANCE , CALORIES , PULSE , AGE . <ul style="list-style-type: none"> ◆ Use the UP or DOWN button to increase or decrease the desired function values of TIME , DISTANCE , CALORIES , PULSE , AGE .
<p>QUICK START START/PAUSE</p> 	<p>**The button is equipped with THREE operating methods**</p> <ol style="list-style-type: none"> QUICK START: Press the button to enter into MANUAL MODE immediately without selecting the function value displays of TIME , DISTANCE , CALORIES , PULSE . START/PAUSE button: <ol style="list-style-type: none"> Press to start a workout. Press to pause the program. <ul style="list-style-type: none"> ◆ The console would display the current function values of workload level, TIME , DISTANCE , CALORIES , PULSE . User can press the START/PAUSE button again to continue to run the current program. <p> NOTE: All of the function values of “TIME”, “DISTANCE”, “CALORIES”, “PULSE” in the memory would turn to initial function values the console was set up after turning off or switching to another mode (“MANUAL”, “PROGRAM”, “USER”, “TARGET H.R.”) .</p>

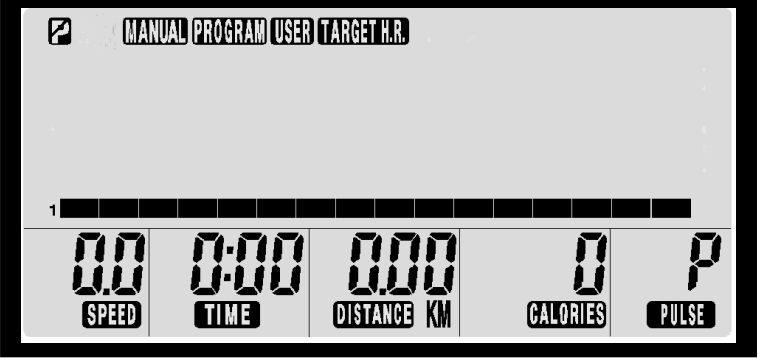
● **FUNCTION BUTTONS:**

Button Name	Function Description
<p style="text-align: center;">RESET</p> 	<p>**The button is equipped with TWO operating methods**</p> <p>a. ZEROING FUNCTION: Press the button to reset each function value to zero during setting.</p> <div style="border: 1px solid black; background-color: black; color: white; padding: 5px; display: flex; align-items: center; justify-content: center;">  <p>The RESET function only operates under PAUSE MODE </p> </div> <p>b. CHANGE SLECTED MODE- MANUAL , PROGRAM , USER , TARGET H.R. :</p> <ul style="list-style-type: none"> ◆ Under PAUSE MODE, Hold the button for FOUR SECONDS to enter into the initial setting mode as shown. <div style="text-align: right; margin-bottom: 10px;">  </div> <div style="border: 2px solid black; padding: 10px; width: fit-content; margin: 0 auto;">  </div> <div style="border: 1px solid black; background-color: black; color: white; padding: 5px; display: flex; align-items: center; justify-content: center; margin-top: 10px;">  <p>The RESET function only operates under PAUSE MODE </p> </div>

COMPUTER OPERATION

There are four ways to enter into **MANUAL MODE** as below:

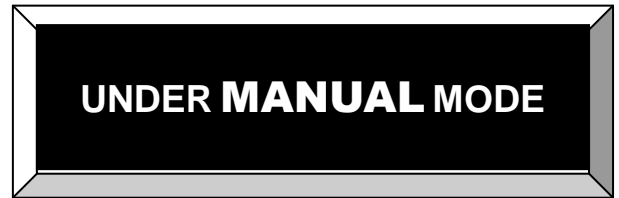

1. POWER OFF STATUS (LCD diagram disappear on LCD window):

- Pedaling to activate the console.
- The activated LCD console lights up along with a long beep sound. LCD diagram appears as shown on right side.

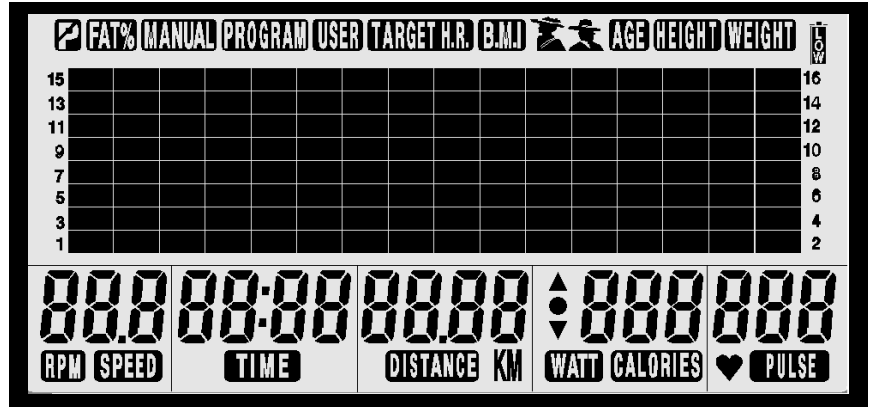

- Enter into the initial setting mode after around two seconds as shown on right side.

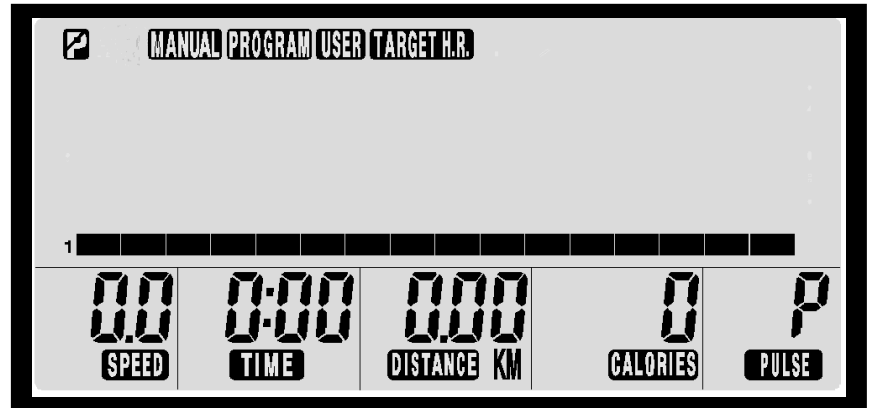

2. RESTART FUNCTION:

- Press the **START/PAUSE** button to pause the current program.
- Hold the **RESET** button for **FOUR SECONDS** to enter into the initial setting mode as illustration shown on the right.

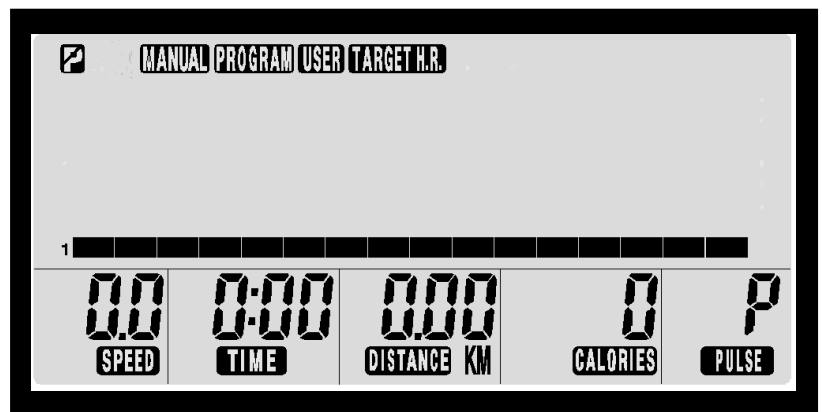

The **RESET** function only operates under **PAUSE MODE**

- Skip to **Step B.** of **NORMAL OPERATION** on the next page to continue the operation.

CONTINUE TO THE NEXT PAGE

COMPUTER OPERATION



3. QUICK START:

- a. **START/PAUSE** button: Press the **START/PAUSE** button directly to start a workout under **MANUAL MODE** without any setting.
- b. Skip to **Step C.** of **NORMAL OPERATION** to select the function value of . **TIME** , **DISTANCE** , **CALORIES** , **PULSE**

Under both PAUSE  or START mode, workload level can be adjusted with the **UP** or **DOWN** button.

4. NORMAL OPERATION:

- a. **START/PAUSE** button: Press the **START/ PAUSE** button to pause the current program.
- b. **PROGRAM** button: Press the **PROGRAM** button to select **MANUAL MODE** while in other mode (**USER** , **PROGRAM** , **TARGET H.R.**)
- c. **ENTER** button: Press the **ENTER** button for confirming and entering the function value setting.
- d.  “PAUSE MODE” single will flash on LCD window for setting.
- e. LCD window then display flashing “workload level” as shown.

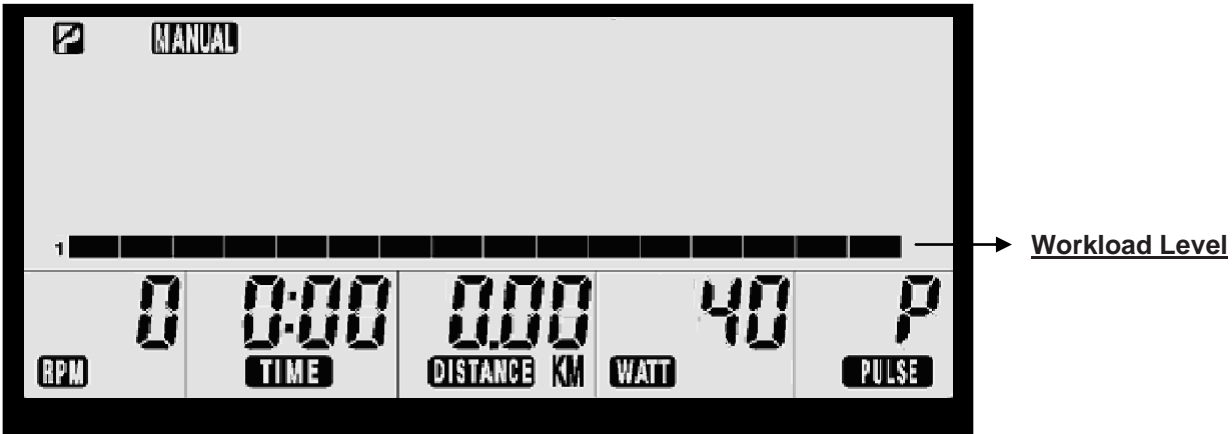

- f. **UP** or **DOWN** button: Press the **UP** or **DOWN** button to increase or decrease the workload level ((1~16 levels, 2 levels increment.)
- g. **START/PAUSE** button: Press the **START/PAUSE** button to start a workout directly without setting function values (**TIME** , **DISTANCE** , **CALORIES** , **PULSE** .) Or **ENTER** button: Press the **ENTER** button to continue to select other function values to adjust the user’s workout.

CONTINUE TO THE NEXT PAGE

COMPUTER OPERATION

- h. After pressing the **ENTER** button, the flashing **TIME** will appear on the LCD window.

UNDER MANUAL MODE

- i. **UP** or **DOWN** button: Press the **UP** or **DOWN** button to the program time as desire.

NOTE: The console will cycle through the functions as follow and allow users to set the function values.

TIME (01:00 to 99:00; 1minute increment) → **DISTANCE** (0.1 to 99.9km; 0.1km increment)→
CALORIES (10 to 990 Kcal; 10 Kcal Increment) → **PULSE** (70 to 240 BPM; 1BPM increment)

- ◆ Press the **ENTER** button to confirm the function value and enter the next function value setting.
- ◆ Press the **UP** or **DOWN** button to select the value of the function (**TIME** , **DISTANCE** , **CALORIES** , **PULSE** .)
- ◆ To reset the function value to zero, press the **RESET** button.

- j. **START/PAUSE** button: To start a workout, press the **START/PAUSE** button .



a. WITHOUT PULSE VALUE:

“” flashing symbol will appear when detecting your pulse.

b. THE WARNING BEEP SOUND EMIT CONSTANLY DURING WORKOUT:





If your pulse is greater than the SELECTED PULSE VALUE during workout, the short warning beep sound will constantly emit.

Please note that this is a warning for you to slow down or to decrease the workload level.

COMPUTER OPERATION

OVERVIEW SETTING VALUES:

Display Readout	Display range	Storage	Zeroing	Description and small tip
TIME	0:00 to 99:00	Yes (During a workout. The selected value will turn to zero after turning off)	Yes (Use RESET button)	<ol style="list-style-type: none"> 1. Time will count up to 99:00 and cycle run the program profile without setting. 2. Time will count down to 0 depends on desired time value users set up. Two short beep sound for warning the selected value reach to zero.
DISTANCE	0.0 to 99.9km	Yes (During a workout. The selected value will turn to zero after turning off)	Yes (Use RESET button)	<ol style="list-style-type: none"> 1. Distance will count up to 99:90km and cycle run the program profile without setting. 2. Distance will count down to 0 depends on desired distance value users set up. Two short beep sound for warning selected value reach to zero..
CALORIES	10 to 990 Kcal	Yes (During a workout. The selected value will turn to zero after turning off)	Yes (Use RESET button)	<ol style="list-style-type: none"> 1. Calories will count up to 990 Kcal and cycle run the program profile without setting. 2. Calories will count down to 10 depends on desired calories value users set up. Two short beep sound for warning selected value reach to 10..
 PULSE	70 to 240 BPM	Yes (During a workout. The selected value will turn to zero after turning off))	Yes (Use RESET button)	<p>1. CONSOLE WITHOUT PULSE VALUE:</p> <p>“” flashing symbol will appear when detecting your pulse.</p> <p>2. WARNING BEEP SOUND EMIT CONSTANTLY FROM A CONSOLE:</p> <ul style="list-style-type: none"> ● If your pulse is greater than the SELECTED PULSE VALUE during workout, the short warning beep sound will constantly emit. ● Please note that this is a warning for you to slow down or decrease the workload level.
WATT		Yes (During a workout. The selected value will turn to zero after turning off)	Yes (Use RESET button)	<p>EACH 6 SECONDS</p> <p>WATT/ CALORIES, RPM/ SPEED WOULD SWITCH DISPLY ON LCD WINDOW</p>
RPM	0 to 250	No	Yes (Auto)	

COMPUTER OPERATION

There are three ways to enter into **PROGRAM MODE** as below:



1. POWER OFF STATUS (LCD diagram disappear on LCD window):

- Pedaling to activate the console.
- The activated LCD console lights up along with a long beep sound. LCD diagram appears as shown on right side.

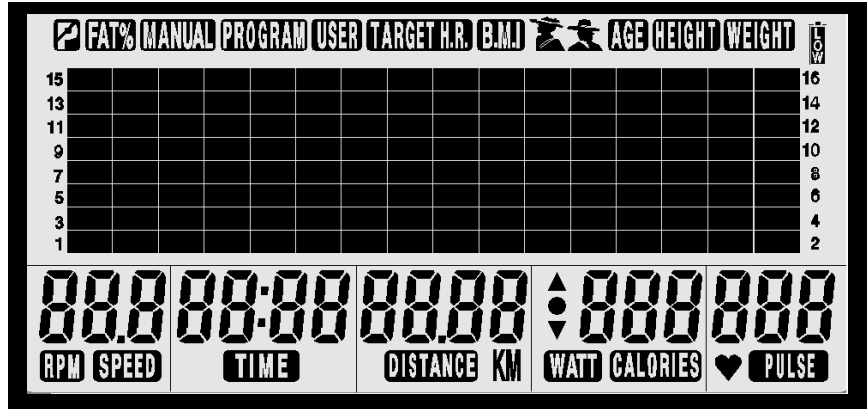

- Enter into the initial setting mode after around two seconds as shown on right side.

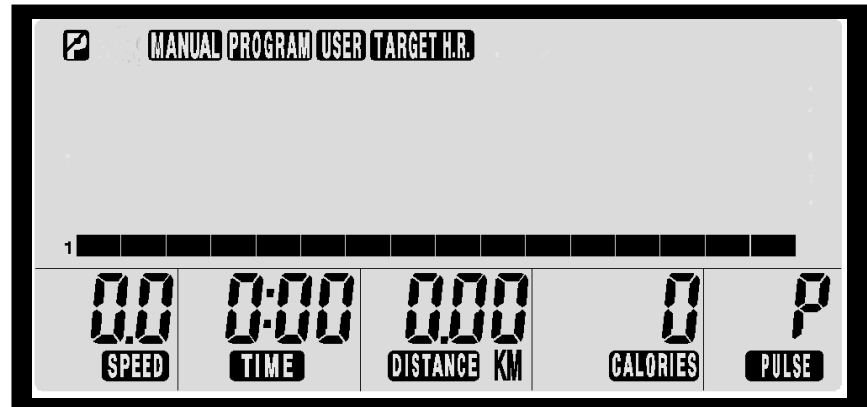

2. RESTART FUNCTION:

- Press the **START/PAUSE** button to pause the current program.
- Hold the **RESET** button for **FOUR SECONDS** to enter into the initial setting mode as illustration shown on the right.

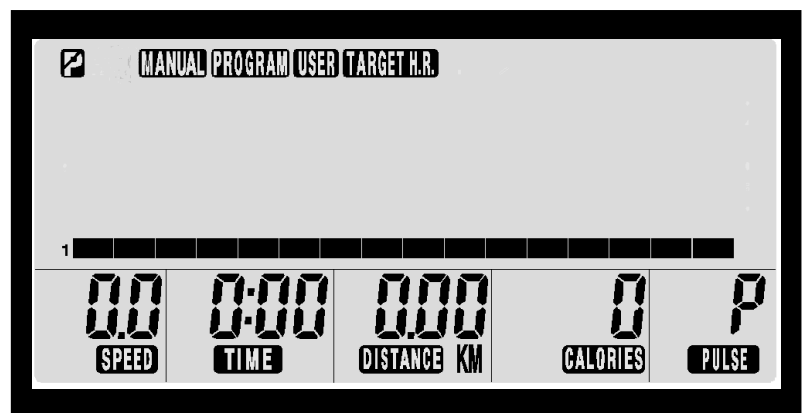
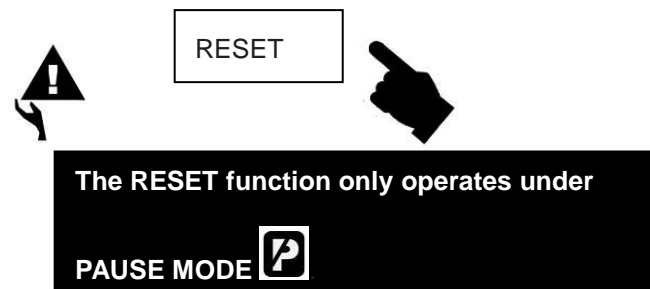

- Skip to **Step B.** of **NORMAL OPERATION** on the next page to continue the operation.

➡ CONTINUE TO THE NEXT PAGE

COMPUTER OPERATION



3. NORMAL OPERATION:

- a. **START/PAUSE** button: Press the **START/ PAUSE** button to pause the current program.
- b. **PROGRAM** button: Press the **PROGRAM** button to select **PROGRAM MODE** while in other mode (**MANUAL** , **USER** , **TARGET H.R.**).

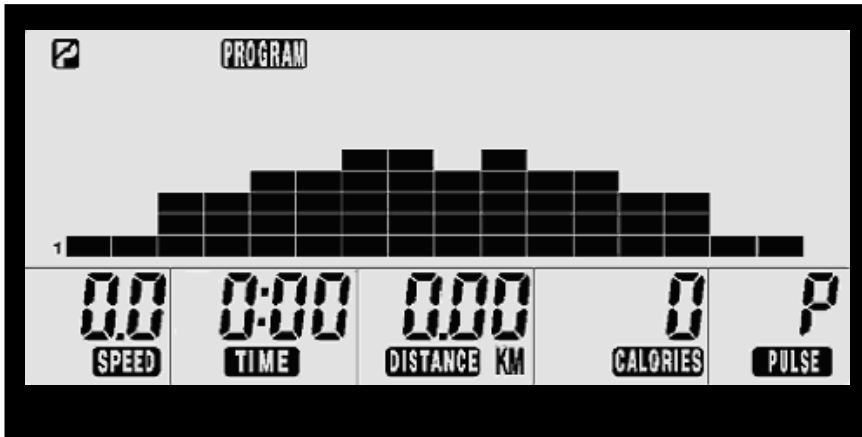

- c. **ENTER** button: Press the **ENTER** button for confirming and entering the function value setting.
- d.  "PAUSE MODE" single will appear on LCD window for setting.
- e. **START/PAUSE** button: After flashing "P1" appears on LCD window, press the **START/PAUSE** button to start a workout directly without setting function values (Profile (P1~P12), **TIME** , **DISTANCE** , **CALORIES** , **PULSE**). Or **UP** or **DOWN** button: press the **UP** or **DOWN** button to directly select the desired profile (P1 to P12) as shown.

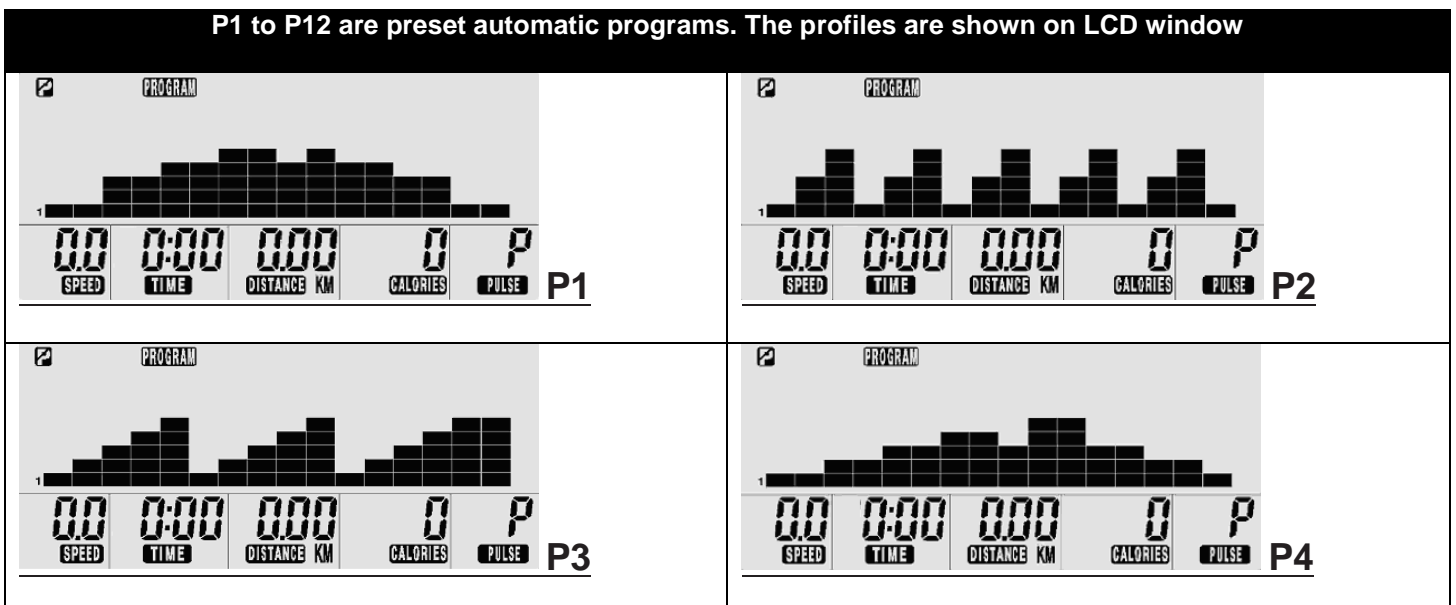

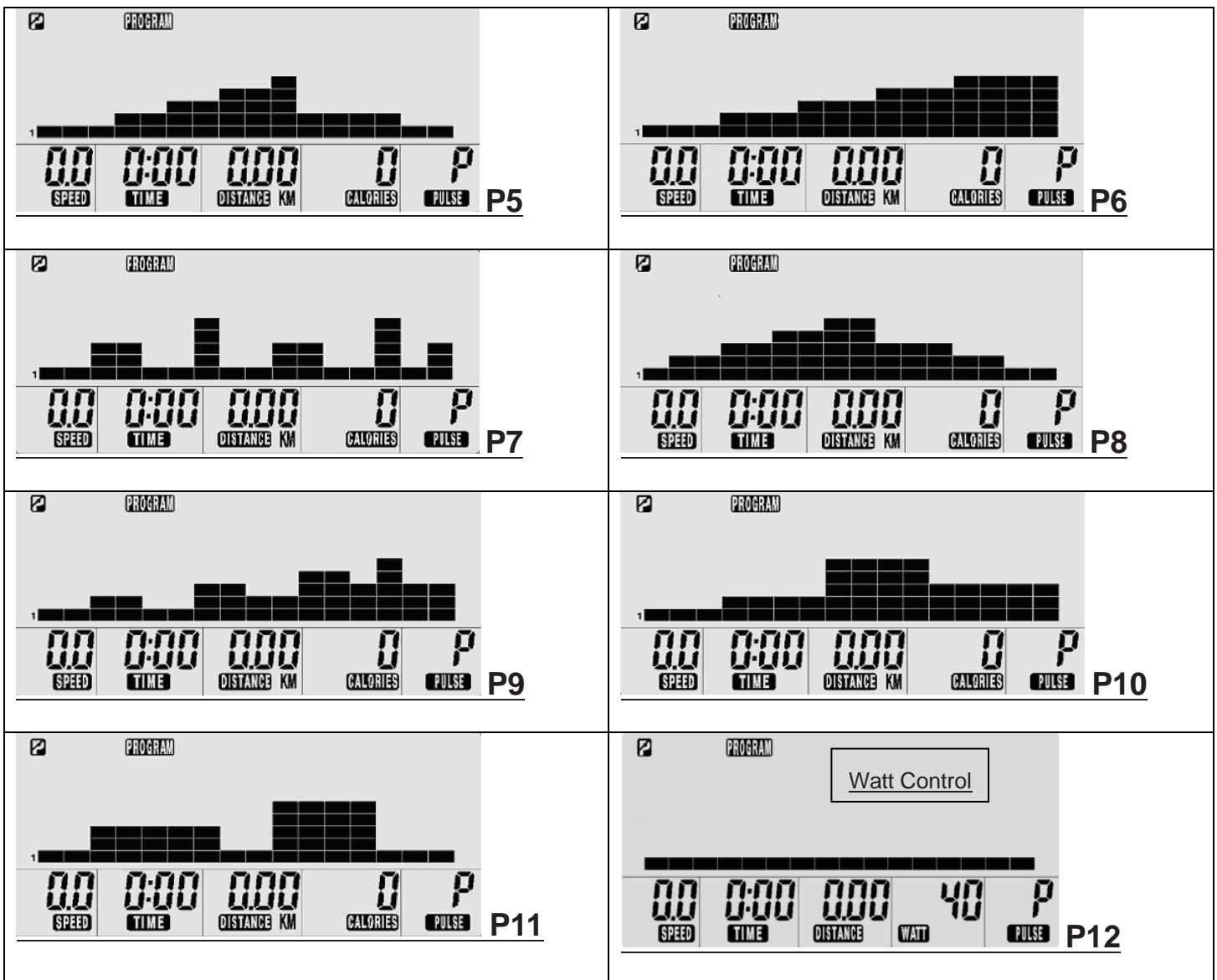

f. After pressing the button, the flashing **TIME** will appear on the LCD window.

g. or button: Press the or button to select the program time as desire.

NOTE: The console will cycle through the functions as follow and allow users to set the function values.

TIME (01:00 to 99:00; 1minute increment) → **DISTANCE** (0.1 to 99.9km; 0.1km increment) →
CALORIES (10 to 990 Kcal; 10 Kcal Increment) → **PULSE** (70 to 240 BPM; 1BPM increment)

- ◆ Press the button to confirm the function value and enter the next function value setting.
- ◆ Press the or button to select the value of the function (**TIME** , **DISTANCE** , **CALORIES** , **PULSE** .)
- ◆ To reset the function value to zero, press the button.

COMPUTER OPERATION

h. **START/PAUSE** button: To start a workout, press the

START/PAUSE button .

UNDER PROGRAM MODE



a. WITHOUT PULSE VALUE:

“” flashing symbol will appear when detecting your pulse.

b. THE WARNING BEEP SOUND EMIT CONSTANLY DURING WORKOUT:



If your pulse is greater than the **SELECTED PULSE VALUE** during workout, the short warning beep sound will constantly emit.

Please note that this is a warning for you to slow down or to decrease the workload level.

The console is equipped with **LEVEL CONTROL** and **WATT CONTROL** function. During **Program 12** under **PROGRAM** mode, the **WATT CONTROL** function is available to operate.

P12 (WATT CONTROL) UNDER PROGRAM MODE

Before operating **P12**, review the difference between the **CONSTANT POWER** and the **CONSTANT TORQUE** function:

Level Control (Constant Torque)	Watt Control (Constant Power)
<p>RPM↓↑ RESISTANCE —</p> <p>Unchangeable resistance even though the value of RPM (Rotate Per Minute) increases or decreases under the Constant Torque Mode during workout.</p> <p>No matter how fast you pedal, the resistance is fixed.</p>	<p>Changeable resistance depends on the value of RPM (Rotate Per Minute.)</p> <p>RPM↑ RESISTANCE↓ ; RPM↓ RESISTANCE ↑</p> <p>In order to remain the value of Watt Control, the value of the RPM (Rotate Per Minute) increases (when you pedal faster), while the value of the Resistance decrease (becomes lighter resistance.)</p> <p>On the contrary, the value of the Resistance would increase (becomes heavier resistance) when the value of the RPM decreases (when you pedal slower.)</p>

COMPUTER OPERATION

- a. **START/PAUSE** button: Press the **START/PAUSE** button to pause the current program.

P12 (WATT CONTROL) UNDER PROGRAM MODE

- b. **RESET** button: Hold the **RESET** button for **FOUR SECONDS** to enter into the initial setting mode as the illustration shown on the right.

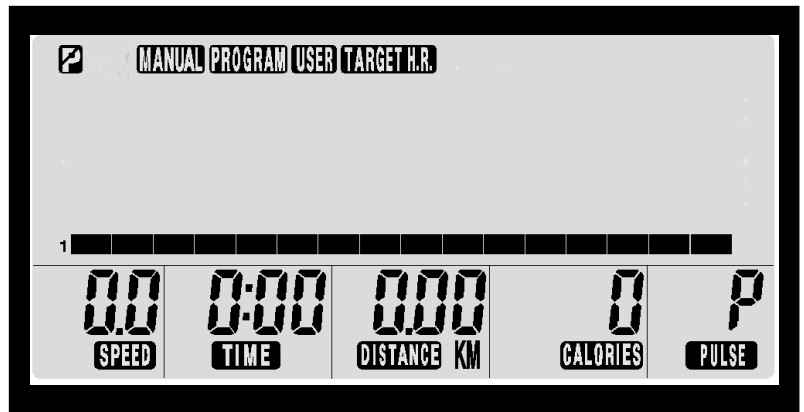

The **RESET** function only operates under **PAUSE MODE** 

- c. **PROGRAM** button: **MANUAL** would then flash on the LCD window. Press the **PROGRAM** button to select **PROGRAM MODE**.
- d. **ENTER** button: Press the **ENTER** button for confirming and entering the function value setting.
- e. **UP** or **DOWN** button: Press the **UP** or **DOWN** button to choose **P12** as the following illustration shown.

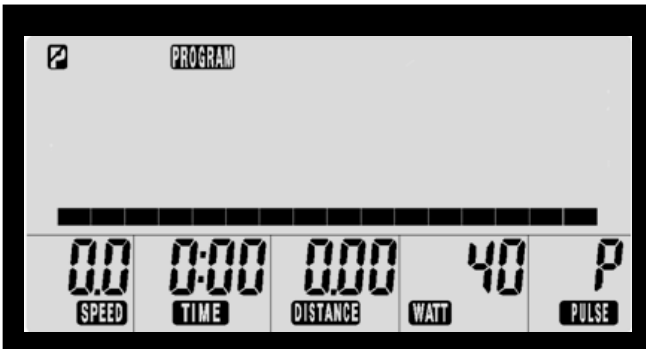

- f. **ENTER** button: Press the **ENTER** button to enter **Program 12**.
- g. **UP** or **DOWN** button: Press the **UP** or **DOWN** button to choose the desired **Watt Control value** (40 ~ 400 Watt; 10 Watt increment.)
- h. **ENTER** button: To continue selecting other function values, press the **ENTER** button.

NOTE: The console will cycle through the functions as follow and allow users to set the function values.

TIME (01:00 to 99:00; 1minute increment) → **DISTANCE** (0.1 to 99.9km; 0.1km increment) → **CALORIES** (10 to 990 Kcal; 10 Kcal Increment) → **PULSE** (70 to 240 BPM; 1BPM increment)

- ◆ Press the **ENTER** button to confirm the function value and enter the next function value setting.
- ◆ To increase or decrease the value of the function (**TIME** , **DISTANCE** , **CALORIES** , **PULSE** ,) press the **UP** or **DOWN** button.
- ◆ To reset the function value to zero, press the **RESET** button.

i. **START/PAUSE** button: After setting up all the function values, press the **START/PAUSE** button to start a workout.

- ◆ Under **PAUSE** or **START** mode, the user could press the **UP** or **DOWN** button to adjust the desired Watt value (40 ~ 400Watt.)



a. WITHOUT PULSE VALUE:

“” flashing symbol will appear when detecting your pulse. Without wearing a chest belt, make sure to always hold the pulse sensors on the handlebars with both hands during a workout.

b. THE WARNING BEEP SOUND EMIT CONSTANLY DURING WORKOUT:



If your pulse is greater than the **SELECTED PULSE VALUE**

during workout, the short warning beep sound will constantly emit.

Please note that this is a warning for you to slow down or to decrease the workload level.

COMPUTER OPERATION

There are three ways to enter into **USER MODE** as below:

UNDER USER MODE

1. POWER OFF STATUS (LCD diagram disappear on LCD window):

- Pedaling to activate the console.
- The activated LCD console lights up along with a long beep sound. LCD diagram appears as shown on right side.

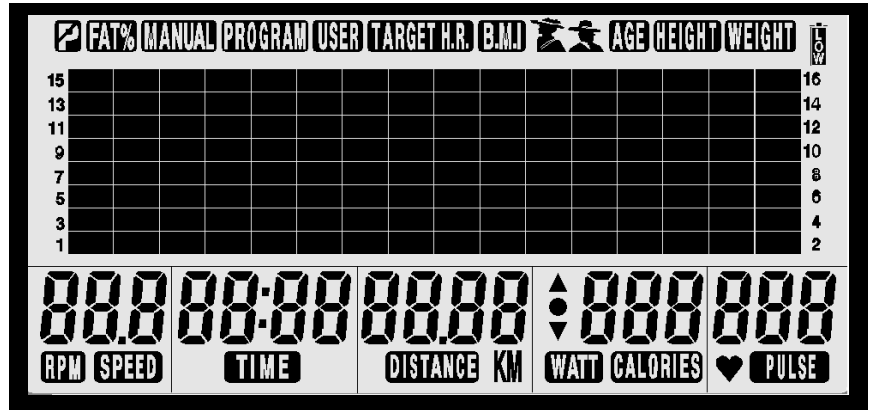

- Enter into the initial setting mode after around two seconds as shown on right side.

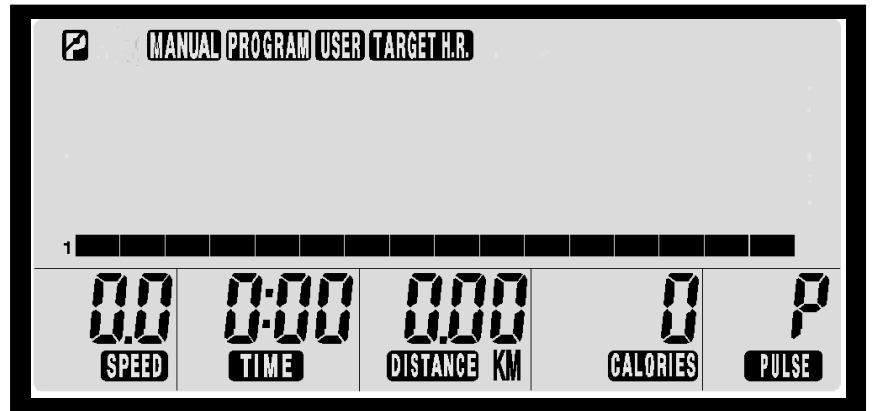

2. RESTART FUNCTION:

- Press the **START/PAUSE** button to pause the current program.
- Hold the **RESET** button for **FOUR SECONDS** to enter into the initial setting mode as illustration shown on the right.

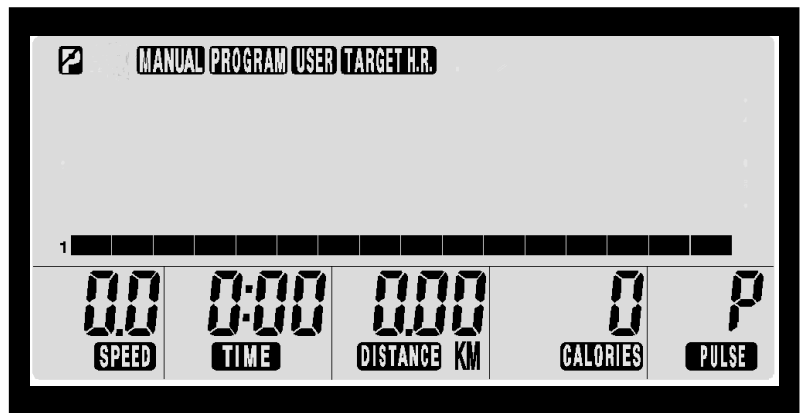
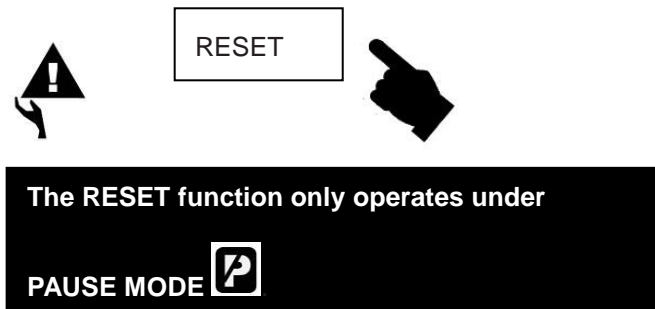

- Skip to **Step B.** of **NORMAL OPERATION** on the next page to continue the operation.

➔ CONTINUE TO THE NEXT PAGE

COMPUTER OPERATION

UNDER USER MODE

3. NORMAL OPERATION:

- a. **START/PAUSE** button: Press the **START/ PAUSE** button to pause the current program.
- b. **PROGRAM** button: Press the **PROGRAM** button to select **USER MODE** while in other mode (**MANUAL** , **PROGRAM** , **TARGET H.R.**)

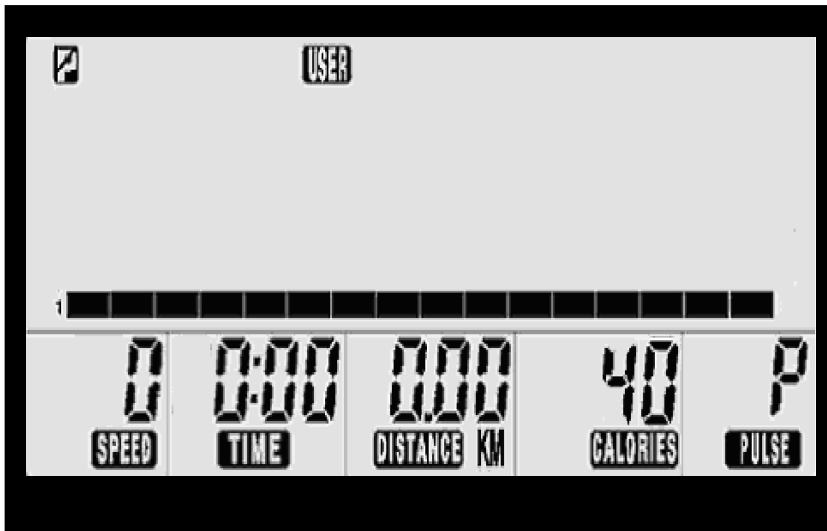

- c. **ENTER** button: Press the **ENTER** button for confirming and entering the function value setting.
- d.  "PAUSE MODE" single will appear on LCD window for setting.
- e. **START/PAUSE** button: After flashing "the first time interval of the workload level" appears on LCD window, press the **START/PAUSE** button to start a workout directly without setting function values (**TIME INTERVAL 1** ... **TIME INTERVAL 16** , **TIME** , **DISTANCE** , **CALORIES** , **PULSE** .)

Or **UP** or **DOWN** button: Press the **UP** or **DOWN** button to preset the desired workload level in each time interval (the console will divide the time into 16 intervals.)

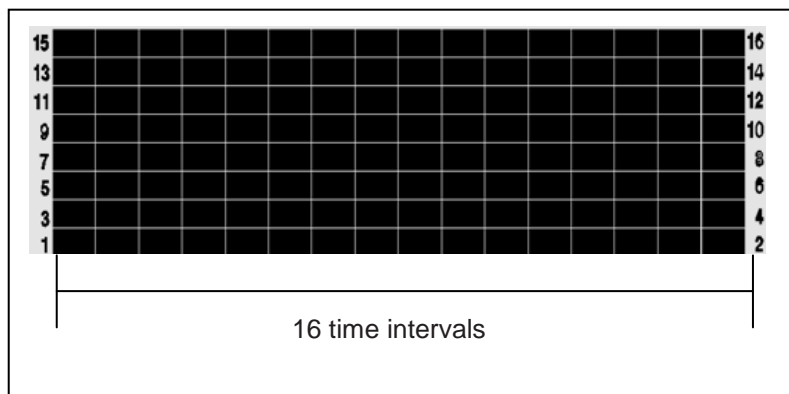

COMPUTER OPERATION

UNDER USER MODE

f. **START/PAUSE** button: Press the **START/PAUSE** button to start a workout directly without setting function values

(**TIME** , **DISTANCE** , **CALORIES** , **PULSE** .)

Or hold the “**ENTER**” button for 3 seconds to continue selecting the other function value of **TIME**, **DISTANCE**, **CALORIES**, **PULSE**.



g. After pressing the **ENTER** button for 3 seconds, the flashing **TIME** will appear on the LCD window.

h. **UP** or **DOWN** button: Press the **UP** or **DOWN** button to the program time as desire.

NOTE: The console will cycle through the functions as follow and allow users to set the function values.

TIME (01:00 to 99:00; 1minute increment) → **DISTANCE** (0.1 to 99.9km; 0.1km increment) → **CALORIES** (10 to 990 Kcal; 10 Kcal Increment) → **PULSE** (70 to 240 BPM; 1BPM increment)

- ◆ Press the **ENTER** button to confirm the function value and enter the next function value setting.
- ◆ Press the **UP** or **DOWN** button to select the value of the function (**TIME** , **DISTANCE** , **CALORIES** , **PULSE** .)
- ◆ To reset the function value to zero, press the **RESET** button.

i. To start a workout, press the **START/PAUSE** button .

- ◆ Under **PAUSE** or **START** mode, the user could press the **UP** or **DOWN** button to adjust workload level.



a. WITHOUT PULSE VALUE:

“” flashing symbol will appear when detecting your pulse.

b. THE WARNING BEEP SOUND EMIT CONSTANLY DURING WORKOUT:

If your pulse is greater than the **SELECTED PULSE VALUE** during workout, the short warning beep sound will constantly emit.

Please note that this is a warning for you to slow down or to decrease the workload level.

COMPUTER OPERATION

There are three ways to enter into **TARGET H.R. MODE** as below:

UNDER TARGET H.R.

MODE as below:

1. POWER OFF STATUS (LCD diagram disappear on LCD window):

- Pedaling to activate the console.
- The activated LCD console lights up along with a long beep sound. LCD diagram appears as shown on right side.

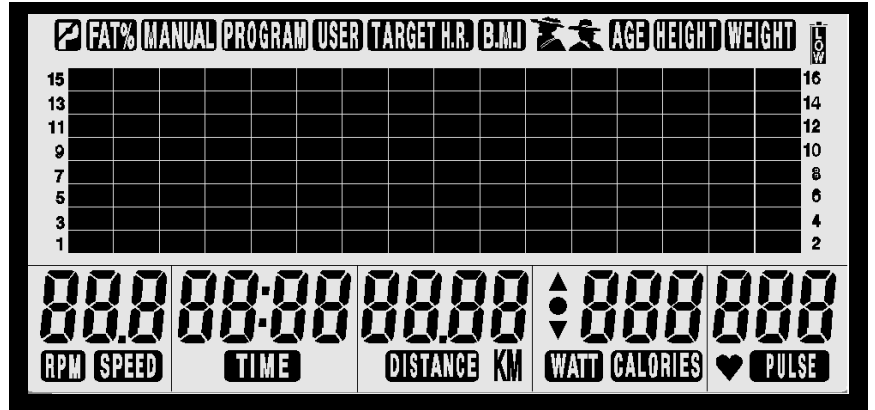

- Enter into the initial setting mode after around two seconds as shown on right side.

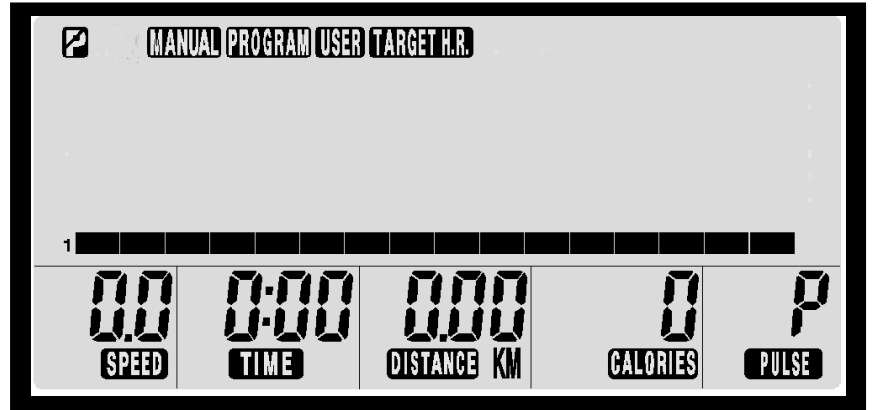

2. RESTART FUNCTION:

- Press the **START/PAUSE** button to pause the current program.
- Hold the **RESET** button for **FOUR SECONDS** to enter into the initial setting mode as illustration shown on the right.

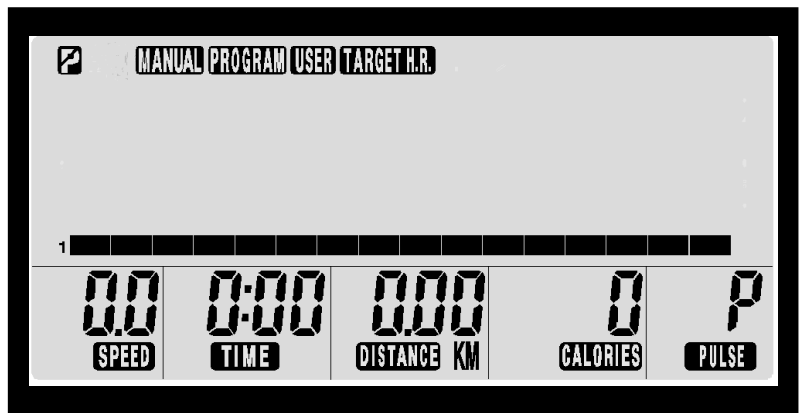

RESET



The **RESET** function only operates under

PAUSE MODE



- Skip to **Step B.** of **NORMAL OPERATION** on the next page to continue the operation.



CONTINUE TO THE NEXT PAGE

COMPUTER OPERATION

3. NORMAL OPERATION:

UNDER TARGET H.R. MODE

a. **START/PAUSE** button: Press the **START/ PAUSE** button to pause the current program.

b. **PROGRAM** button: Press the **PROGRAM** button to select **TARGET H. R.** as shown.

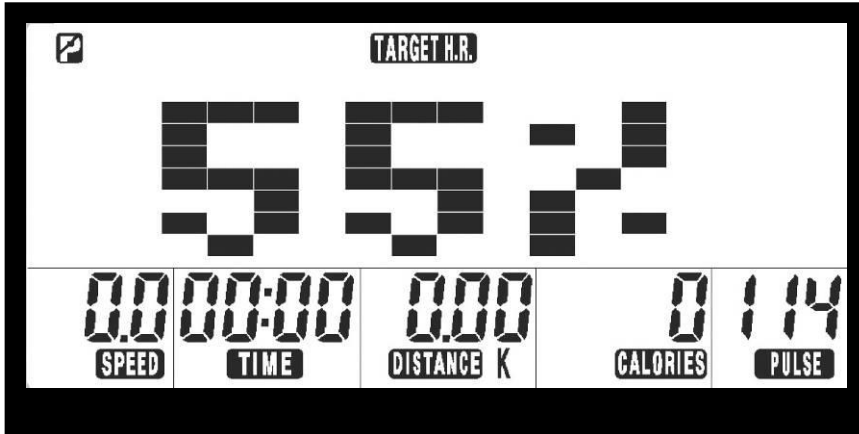

c. **ENTER** button: Press the **ENTER** button for confirming and entering the function value setting.

d.  "PAUSE MODE" single will appear on LCD window for setting.

e. **UP** or **DOWN** button: After flashing the age value the console preset appear on the LCD window, press the **UP** or **DOWN** button to select your age.



Note: Please note that although the console allows input for age beginning at 10 years old, the product is not recommended for children's use.

f. **ENTER** button: Press the **ENTER** button to confirm the user's age.

g. **UP** or **DOWN** button: Continue to select the TARGET H.R. (55%, 75%, 90%, THR) you desire with the **UP** or **DOWN** button .

◆ If choose the TARGET H.R. of 55%, 75%, 90%, skip **STEP H.** and operate **STEP I.** directly.

OVERVIEW SIMPLE FORMULA:

55% = 55% OF (220 – AGE)

75% = 75% OF (220 – AGE)

90% = 90% OF (220 – AGE)

THR = Set by user (70 ~ 240 BPM)

COMPUTER OPERATION

UNDER TARGET H.R. MODE

h. **UP** or **DOWN** button: If choose **THR** mode, the function value of pulse (70 to 240 RPM) will flash on the LCD window.

Press the **UP** or **DOWN** button to set the desired value for the target heart rate.

i. After the **ENTER** button, the flashing **TIME** will appear on the LCD window.

j. **UP** or **DOWN** button: Press the **UP** or **DOWN** button to the select the function value of **TIME** as desire.

NOTE: The console will cycle through the functions as follow and allow users to set the function values.

TIME (01:00 to 99:00; 1minute increment) → **DISTANCE** (0.1 to 99.9km; 0.1km increment)→
CALORIES (10 to 990 Kcal; 10 Kcal Increment) → **PULSE** (70 to 240 BPM; 1BPM increment)

- ◆ Press the **ENTER** button to confirm the function value and enter the next function value setting.
- ◆ Press the **UP** or **DOWN** button to select the value of the function (**TIME** , **DISTANCE** , **CALORIES** , **PULSE** .)
- ◆ To reset the function value to zero, press the **RESET** button.

k. **START/PAUSE** button: To start a workout, press the **START/PAUSE** button .



a. WITHOUT PULSE VALUE:

“” flashing symbol will appear when detecting your pulse.

b. THE WARNING BEEP SOUND EMIT CONSTANLY DURING WORKOUT:



If your pulse is greater than the **SELECTED PULSE VALUE** during workout, the short warning beep sound will constantly emit.

Please note that this is a warning for you to slow down or to decrease the workload level.

WARM-UP and COOL-DOWN

Warm-up The purpose of warming up is to prepare your body for exercise and to minimize injuries. Warm up for two to five minutes before strength-training or aerobic exercising. Perform activities that raise your heart rate and warm the working muscles. Activities may include brisk walking, jogging, jumping jacks, jump rope, and running in place.

Stretching Stretching while your muscles are warm after a proper warm-up and again after your strength or aerobic training session is very important. Muscles stretch more easily at these times because of their elevated temperature, which greatly reduces the risk of injury. Stretches should be held for 15 to 30 seconds. Do not bounce.

Suggested Stretching Exercise

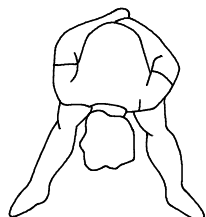

Lower Body Stretch

Place feet shoulder-width apart and lean forward.

Keep this position for 30 seconds using the body as a natural weight to stretch the backs of the legs. **DO NOT BOUNCE!** When the pull on the back

of the legs lessen, try a lower position gradually.



Floor Stretch

While sitting on the floor, open the legs as wide as possible. Stretch the upper body toward the knee on the right leg by using your arms to pull your chest to your thighs. Hold this stretch 10 to 30 seconds. **DO NOT BOUNCE!** Do this stretch 10 times. Repeat the stretch with the left leg.

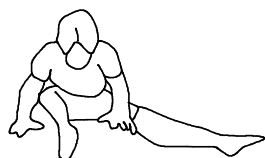

Bent Torso Pulls

While sitting on the floor, have legs apart one leg straight and one knee bent. Pull the chest down to touch the thigh on the leg that is bent and twist at the waist. Hold this position at least 10 seconds. Repeat 10 times on each side.



Bent Over Leg Stretch

Stand with feet shoulder-width apart and lean forward as illustrated. Using the arms, **gently** pull the upper body towards the right leg. Let the head hang down. **DO NOT BOUNCE!** Hold the position a minimum of 10 seconds. Repeat pulling the upper body to the left leg. Do this stretch several times slowly.

Remember always to check with your physician before starting any exercise program.

Cool-Down The purpose of cooling down is to return the body to its normal, or near normal, resting state at the end of each exercise session. A proper cool-down slowly lowers your heart rate and allows blood to return to the heart. Your cool-down should include the stretches listed above and should be completed after strength-training session.

PARTS LIST

NO.	PARTS NAME	Q'TY
1	Main Frame	1
2	Front Stabilizer	1
3	Rear Stabilizer	1
4	Seat Post	1
5	Upright Post	1
6	Handlebar	1
7	Left Cover	1
8	Right Cover	1
9	Crank Cover	2
10	Left Pedal	1
11	Right Pedal	1
12	Front Decorating Upright Cover	1
13	Console	1
14	Console Bracket	1
15	Console Lower Case	1
16	Battery Door	1
17	Accessory Tray	1
18	Upright Sleeve	1
19	Seat	1
20	Seat Lower Case	1
21	Seat post Sleeve	1
22	Seat Cap	1
23	Adjustment Bar	1
24	Slider	1
25	EndCap (50x100mm)	4
26	Moving Wheel	2
27	Leveler (ψ50)	4
28	Hand Wrist Pad	2
29	Foam Grip (550mm)	2

NO.	PARTS NAME	Q'TY
30	Foam Grip (40mm)	2
31	Pulse Sensor Top Housing	2
32	Pulse Sensor Bottom Housing	2
33	Pulse Sensor Plate	4
34	Generator	1
35	Pulley (120mm)	1
36	Belt (762mm J8)	1
37	Pulley (235mm)	1
38	Magnet	1
39	Belt (1092mm J8)	1
40	Front Aluminum Upright Cover	1
41	Rear Aluminum Upright Cover	1
42	Air Pressure Bar	1
43	Seat Adjustment Lever	1
44	Fixed Stand	1
45	Spacer	1
46	Cable	1
47	Cable Spring	1
48	Roller Axle	1
49	Stand Spring	1
50	Spacer Stand	1
51	Arc Washer	1
52	Resistor	1
53	Controller	1
54	Right Mounting Plate	1
55	Left Mounting Plate	1
56	Idler Spring	1
57	Washer (ψ10.6×ψ60×2.0t)	1
58	Idler Arm	1

NO.	PARTS NAME	Q'TY
59	Axle Connection Cap	1
60	Bearing 6004ZZ	8
61	Idler Wheel Spacer	1
62	One Way Pulley (51)	1
63	One Way Bearing (2520)	1
64	Axle	1
65	Right Crank	1
66	Left Crank	1
65	Right Crank	1
66	Left Crank	1
67	Crank Shaft	1
68	Eye Bolt	4
69	Tension Bracket	2
70	Square Key (6×6×15mm)	1
71	E Ring	1
72	Crescent Ring	3
73	Washer (8×38×2.0t)	4
74	Washer (10×23×2.0t)	2
75	Washer (17×25×1.0t)	1
76	Washer (18.3×25×1.0t)	1
77	Washer (20×1.0t)	2
78	Lock Washer (M8)	15
79	Screw (M3×10mm)	1
80	Screw (M4×20mm)	4
81	Screw (M5×18mm)	19
82	Screw, Round Head (M3×35mm)	4
83	Screw, Round Head (M5×p0.8×15mm)	12
84	Screw, Round Head (M5×p0.8×50mm)	2
85	Screw, Round Head (M5×p0.8×75mm)	2
86	Bolt, Round Head (M6×p1.0×10mm)	4
87	Bolt, Socket Head (M6×p1.0×15mm)	4

88	Bolt, Button Head (M6×p1.0×12mm)	4
89	Bolt, Button Head (M8×35mm)	2
90	Bolt, Button Head (M8×p1.25×16mm)	5
91	Bolt, Button Head (M10×p1.5×45mm)	1
92	Screw, Flat Head (M8×p1.25×12mm)	5
93	Bolt, Socket Head (M8×p1.25×70mm)	2
94	Bolt, Socket Head (M10×p1.5×30mm)	1
95	Bolt, Hex Head (M8×p1.25×15mm)	4
96	Bolt, Hex Head (M8×p1.25×15mm)	1
97	Bolt, Hex Head (M8×p1.25×65mm)	4
98	Bolt, Hex Head (M8×p1.25×80mm)	4
99	Bolt, Hex Head (M10×p1.5×50mm)	2
100	Nut (M3)	4
101	Flange Nut (M10)	1
102	Nut (M6)	3
103	Nut (M8)	3
104	Nylock Nut (M6)	2
105	Nylock Nut (M8×6.2t)	8
106	Nylock Nut (M8)	6
107	Nylock Nut (M10)	4
108	Generator Wire	2
109	Middle Connection Wire	1
110	Lower Connection Wire	1
111	Sensor Wire	1
112	Middle Pulse Sensor Wire	1
113	Lower Pulse Sensor Wire	2
114	Washer (8×23×2.0t)	2
115	Nut (M10×p1.25)	1
117	Bushing (4.6mm)	1
118	Bushing (36mm)	1

PRODUCT PARTS DRAWING

