

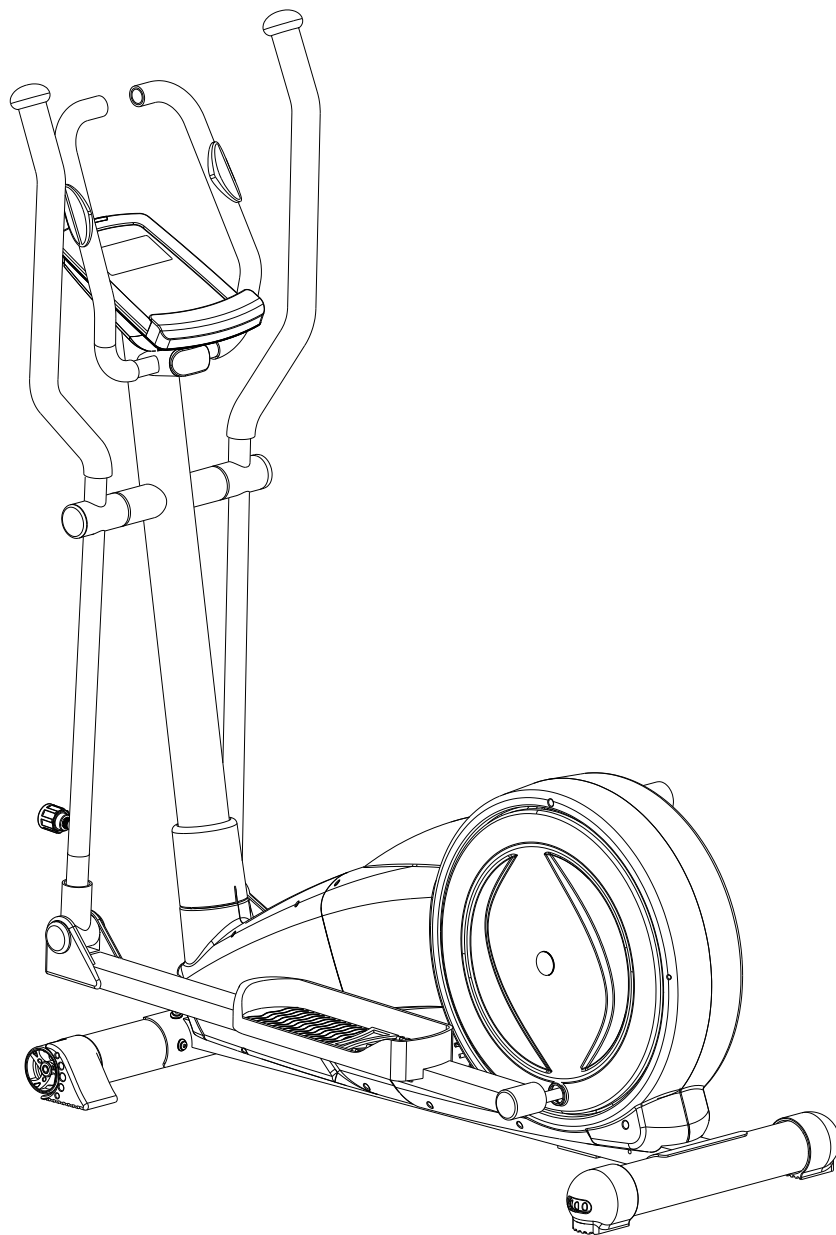

USER MANUAL – EN
IN 8726 Elliptical Trainer inSPORTline ET500i



CONTENTS

SAFETY INSTRUCTIONS..... 3

IMPORTANT NOTES 3

EXPLODED DRAWING..... 5

PARTS LIST 6

CHECKLIST (CONTENTS OF PACKAGE)..... 9

ASSEMBLY 10

CONTROL PANEL 14

TERMS AND CONDITIONS OF WARRANTY, WARRANTY CLAIMS..... 18

SAFETY INSTRUCTIONS

- To ensure the best safety of the exerciser, regularly check it on damages and worn parts.
- If you pass on this exerciser to another person or if you allow another person to use it, make sure that that person is familiar with the content and instructions in these instructions.
- Only one person should use the exerciser at a time.
- Before the first use and regularly make sure that all screws, bolts and other joints are properly tightened and firmly seated.
- Before you start your work-out, remove all sharp-edged objects around the exerciser.
- Only use the exercise for your work-out if it works flawlessly.
- Any broken, worn or defective part must immediately be replaced and/or the exerciser must no longer be used until it has been properly maintained and repaired.
- Parents and other supervisory persons should be aware of their responsibility, due to situations which may arise for which the exerciser has not been designed and which may occur due to children's natural play instinct and interest in experimenting.
- If you do allow children to use this exerciser, be sure to take into consideration and assess their mental and physical condition and development, and above all their temperament. Children should use the exerciser only under adult supervision and be instructed on the correct and proper use of the exerciser. The exerciser is not a toy.
- Make sure there is sufficient free space around the exerciser when you set it up.
- To avoid possible accidents, do not allow children to approach the exerciser without supervision, since they may use it in a way for which it is not intended due to their natural play instinct and interest in experimenting.
- Please note that an improper and excessive work-out may be harmful to your health.
- Please note that levers and other adjustment mechanisms are not projecting into the area of movement during the work-out.
- When setting up the exerciser, please make sure that the exerciser is standing in a stable way and that any possible unevenness of the floor is evened out.
- Always wear appropriate clothing and shoes which are suitable for your work-out on the exerciser. The clothes must be designed in a way so that they will not get caught in any part of the exerciser during the work-out due to their form (for example, length). Be sure to wear appropriate shoes which are suitable for the work-out, firmly support the feet and which are provided with a non-slip sole.
- Be sure to consult a physician before you start any exercise program. He may give you proper hints and advice with respect to the individual intensity of stress for you as well as to your work-out and sensible eating habits.

IMPORTANT NOTES

- Assemble the exerciser as per assembly instructions and be sure to only use the structural parts provided with the exerciser and designed for it. Prior to the assembly, make sure the contents of the delivery is complete by referring to the parts list of the assembly and operating instructions.
- Be sure to set up the exerciser in a dry and even place and always protect it from humidity. If you wish to protect the place particularly against pressure points, contamination, etc., it is recommended to put a suitable, non-slip mat under the exerciser.

- The general rule is that exercisers and training devices are no toys. Therefore, they must only be used by properly informed or instructed persons.
- Stop your work-out immediately in case of dizziness, nausea, chest pain or any other physical symptoms. In case of doubt, consult your physician immediately.
- Children, disabled and handicapped persons should use the exercise only under supervision and in presence of another person who may give support and useful instructions.
- Be sure that your body parts and those of other persons are never close to any moving parts of the exerciser during its use.
- When adjusting the adjustable parts, make sure they are adjusted properly and note the marked, maximum adjusting position, for example of the saddle support, respectively.
- Do not work out immediately after meals!

EXPLODED DRAWING

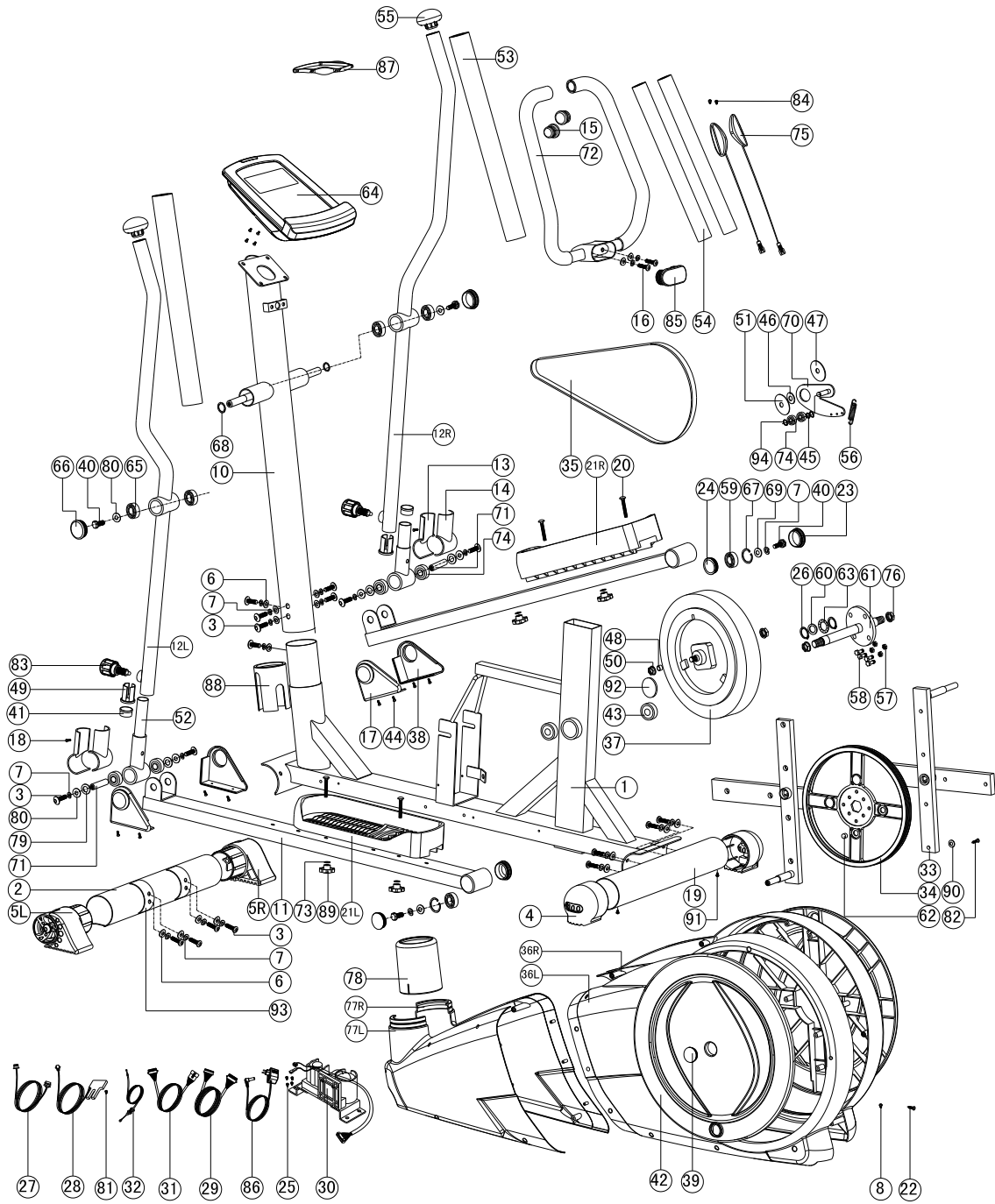











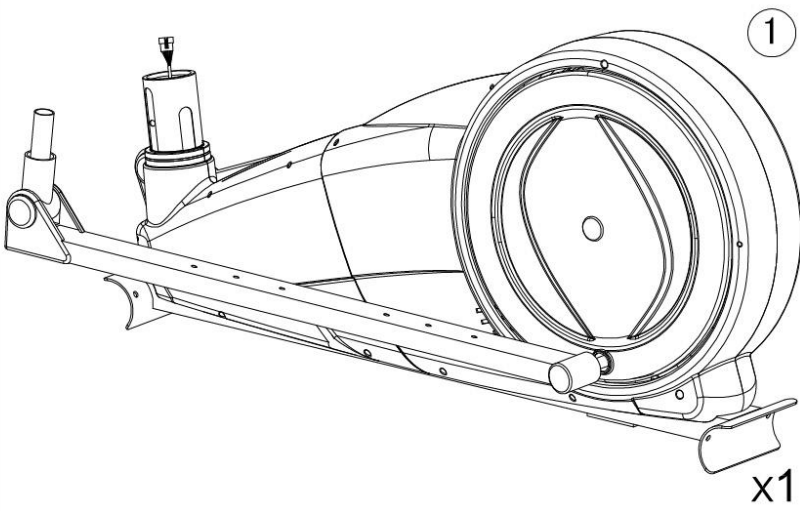
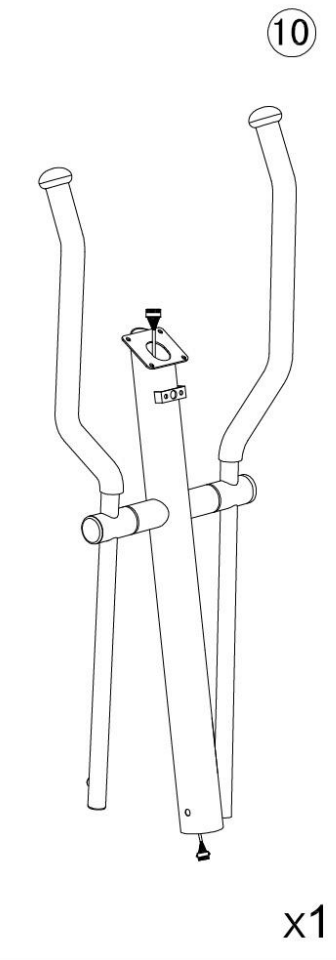
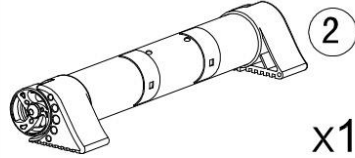
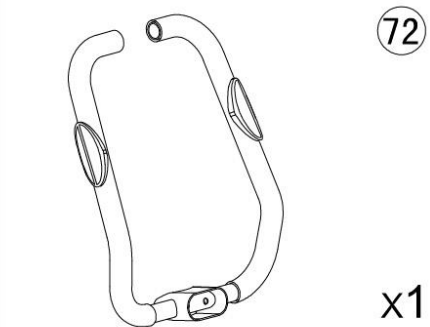
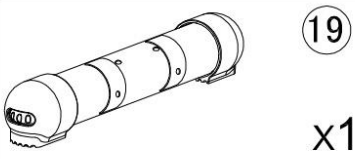
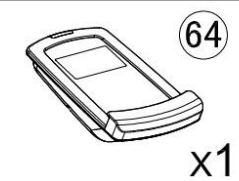
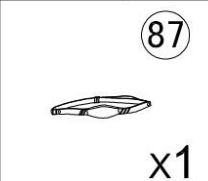
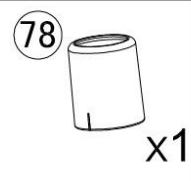

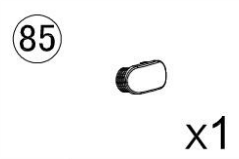
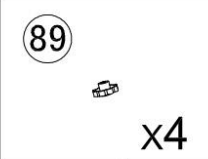
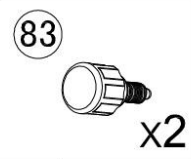
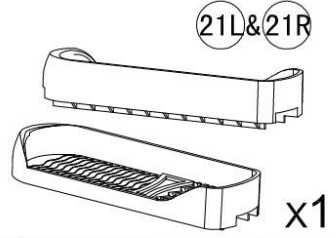



PARTS LIST

Part No.	Description	Qty
1	Main frame	1
2	Front stabilizer	1
3	Allen bolt M8x1.25x20L	18
4	Adjustable cap	2
5L	Left moveable cap	1
5R	Right moveable cap	1
6	Curved washer D22xD8.5x1.5T	16
7	Spring washer D15.4*D8.2*2.0T	22
8	Screw ST4x10L	6
10	Handlebar post	1
11	Pedal supporting tube	2
12L	Left moveable handlebar	1
12R	Right moveable handlebar	1
13	Front foot cap (inner)	2
14	Front foot cap (outer)	2
15	Half ball cap	2
16	Allen bolt M8*1.25*45	2
17	Protective cover (left)	2
18	Screw ST4x1.41x15L	2
19	Rear stabilizer	1
20	Square neck bolt M6*1*45L	4
21L	Left pedal	1
21R	Right pedal	1
22	Screw ST4.2x1.4x20L	19
23	Round cap	2
24	Round cap	2
25	Screw ST4.2x1.4x20L	4
26	C-clip D22.5*D18.5*1.2T	2
27	Electric cable	1
28	Sensor cable	1
29	Upper computer cable	1
30	Motor	1
31	Lower computer cable	1
32	Tension cable	1
33	Crank	2

34	Belt wheel	1
35	Belt	1
36L	Left chain cover	1
36R	Right chain cover	1
37	Flywheel	1
38	Protective cover (right)	2
39	Side cover	2
40	Bolt M8*1.25*20L	4
41	Fixing ring	2
42	Round cover	2
43	Bearing #6004-2RS (C0)	2
44	Screw ST3.5*1.27*15L	8
45	Waved washer D21*D16.2*0.3T	1
46	Metal flat washer D30*D10*4.0T	1
47	Flat washer D50*D10*3T	1
48	Spacer (small) D10*D14*3T	1
49	Inner tube	2
50	Anti-loosen nut 3/8"-26UNFx6.5T	2
51	Plastic washer D50*D10*1.0T	1
52	Supporting tube for moveable bar	2
53	Foam	2
54	Foam	2
55	Mushroom cap	2
56	Spring D4.0xD20x82L	1
57	Nylon nut M6x1.0x6T	4
58	Bolt M6x1.0x15L	4
59	Bearing #2203-2RS	2
60	Flat washer D26*D21*1.5T	1
61	Crank axle	1
62	Round magnet	1
63	Waved washer D27*D20.3*0.5T	1
64	Computer	1
65	Bearing #6004-2RS (C0)	4
66	Round cap	2
67	C-clip S-40 (1.80T)	2
68	Waved washer D27*D20.3*0.5T	2
69	Flat washer D21*D8.5*1.5T	2
70	Fixing plate for idle wheel	1

71	Front pedal axle	2
72	Fixed bar	1
73	Flat washer D14xD6.5x0.8T	4
74	Bearing #99502	6
75	Handle pulse sensor	2
	Handle pulse cable	2
76	Anti-loosen nut M10*1.25*10T	2
77L	Front left chain cover	1
77R	Front right chain cover	1
78	Upper protective cover	1
79	Flat washer D23*D17*1.2T	4
80	Flat washer D25xD8.5x2.0T	6
81	Bolt M5*0.8*10L	1
82	Screw ST4*1.41*15L	16
83	Knob	2
84	Screw ST4x1.41x20L	2
85	End cap	1
86	Adaptor	1
87	Chest belt	1
88	Inner tube	1
89	Club knob	4
90	Flat washer D12*D4.3*1T	16
91	Screw ST4x1.41x10.L	2
92	Screw cover	2
93	Buffer 20*90*1.7T	4
94	C-clip S-16(1T)	2

CHECKLIST (CONTENTS OF PACKAGE)

 <p>1 x1</p>			 <p>10 x1</p>		
 <p>2 x1</p>		 <p>72 x1</p>			
 <p>19 x1</p>					
 <p>64 x1</p>	 <p>87 x1</p>	 <p>78 x1</p>	 <p>86 x1</p>		
 <p>85 x1</p>	 <p>89 x4</p>	 <p>83 x2</p>	 <p>21L&21R x1</p>		
 <p>3 x14</p>	 <p>M8*1.25*20L x14</p>	 <p>6 x16</p>	 <p>D22*D8.5*1.5T x16</p>	 <p>7 x16</p>	 <p>D15.4*D8.2*2T x16</p>
 <p>16 x2</p>	 <p>M8*1.25*45L x2</p>	 <p>20 x4</p>	 <p>M6*1*45L x4</p>	 <p>73 x4</p>	 <p>D14*D6.5*0.8T x4</p>
 <p>x1</p>					

ASSEMBLY

STEP 1

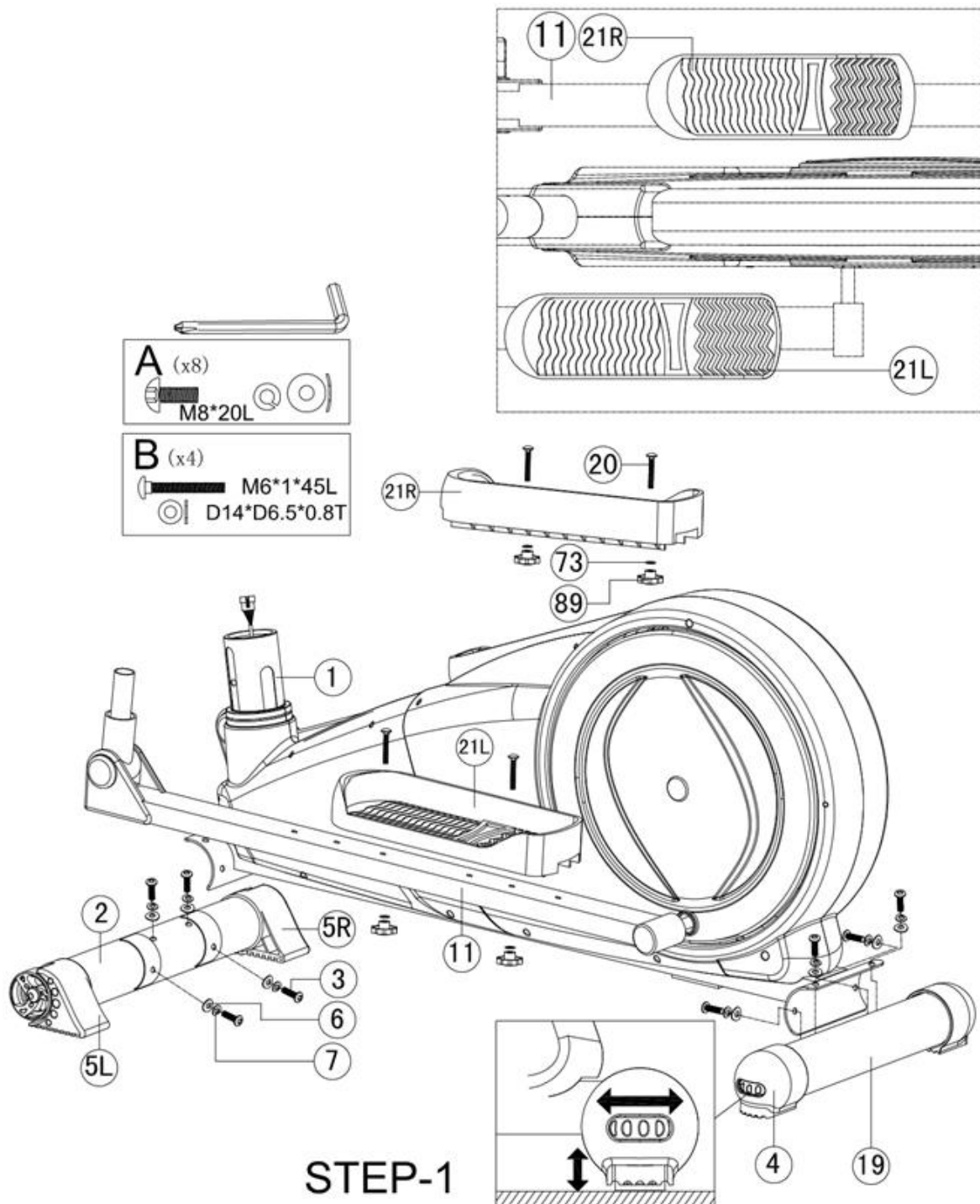

STEP-1

- 1) Assemble the front stabilizer (2) and rear stabilizer (19) onto the main frame (1) by using the allen bolt (3), the curved washer (6), the spring washer (7).
- 2) Adjust the proper height by turning the wheel of rear foot cap (4).
- 3) Assemble the left and right pedal (21L&21R) on the pedal supporting tube (11) by using the carriage bolt (20), flat washer (73) and knob (89)
- 4) 3 optional positions for the pedals.

STEP 2

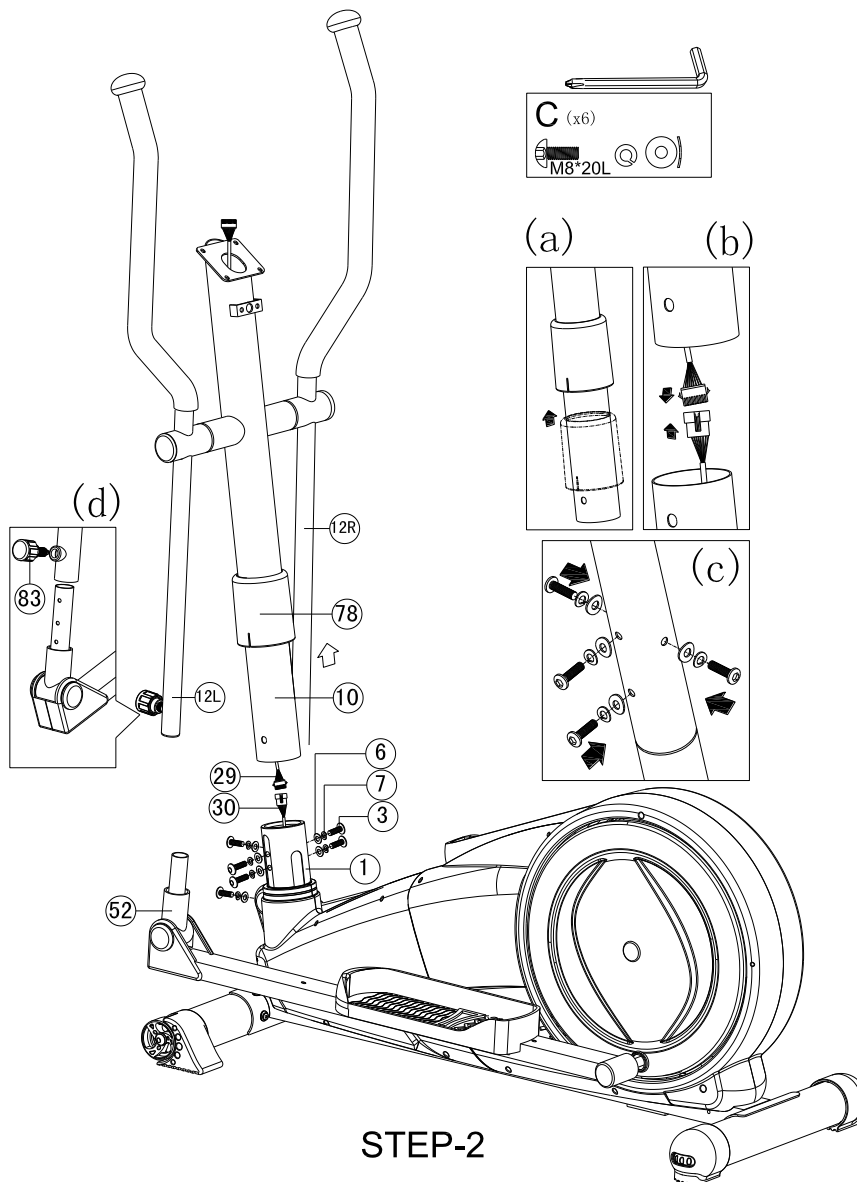

STEP-2

- 1) Suggest assembling this step by two persons.
- 2) First, lift up the cover for handlebar post (78) like fig. (a), then connect computer cable (29) with the cable of motor (30) like fig.(b)
- 3) Insert the handlebar post (10) on the main frame and tighten it by using the curved washer (6), the spring washer (7) and the allen bolt (3). Place down the cover for handlebar post (78) and make it tight on the main frame.
- 4) Assemble the left and right movable handlebar (12L&12R) on the movable handlebar support (52) by using smaller adjustable knob (83) like fig.(d)
- 5) You can adjust the height of swing handlebar by using the knob.

STEP 3

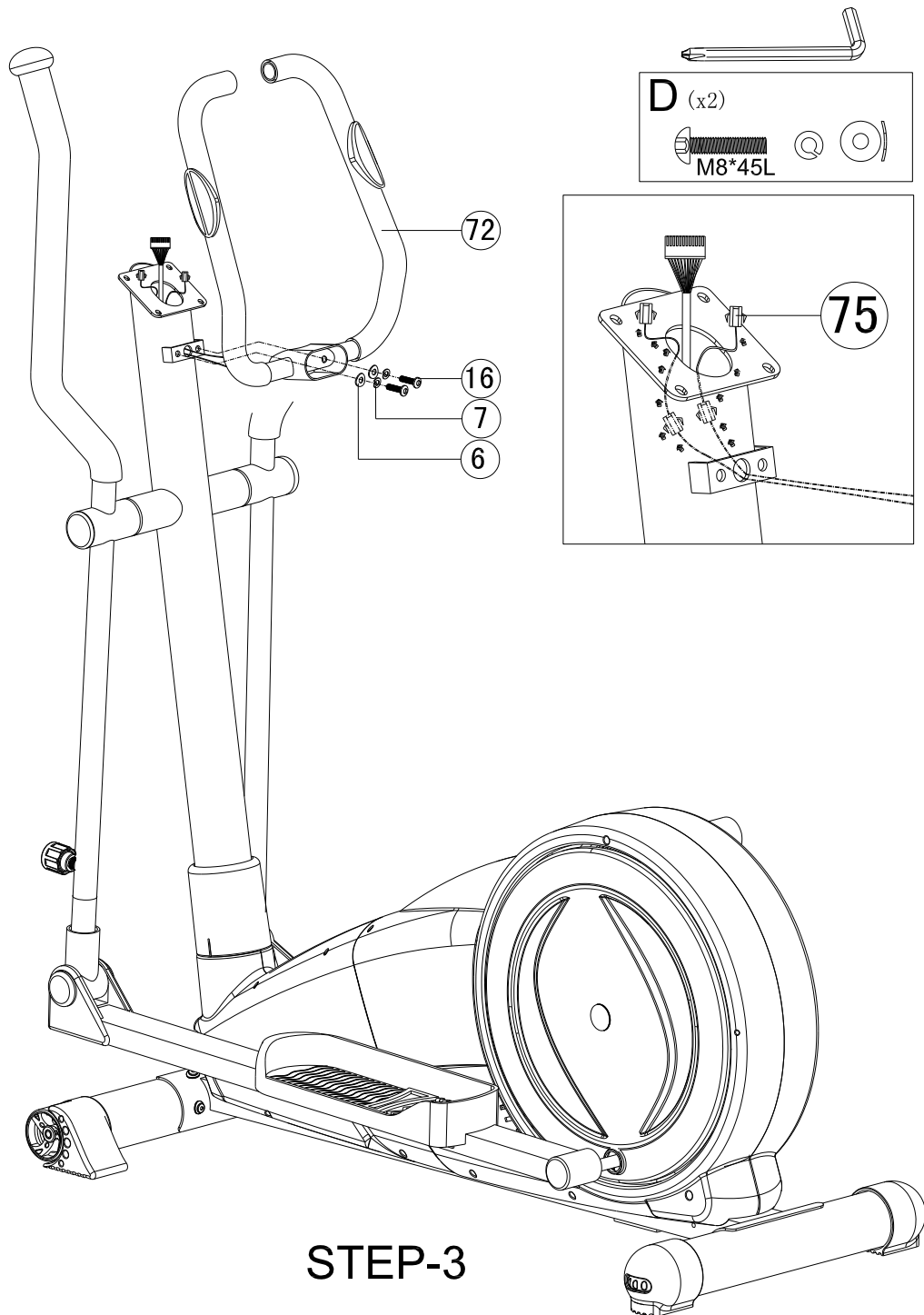

STEP 4

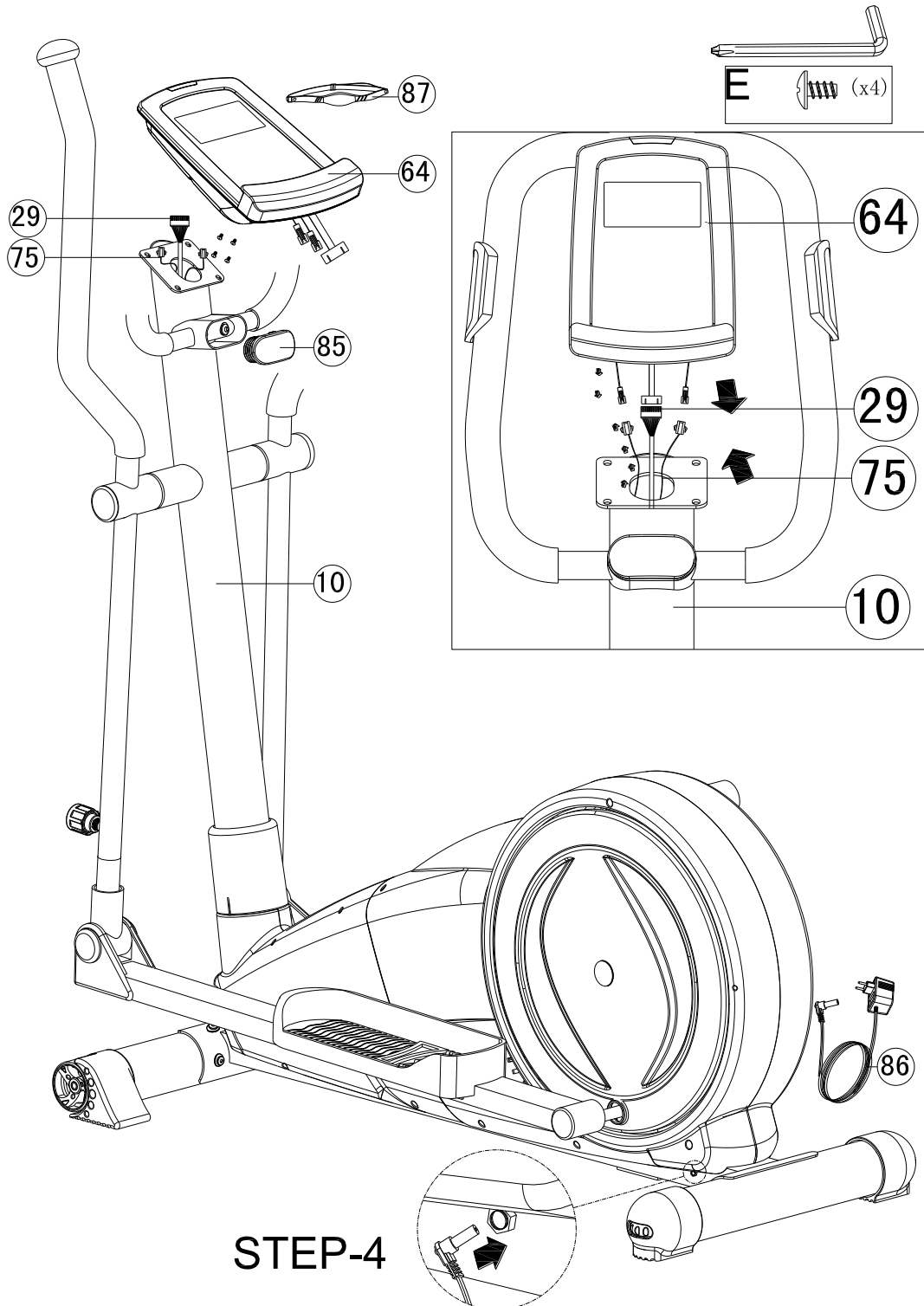

- 1) Connect the computer cable (29) and cable of hand pulse sensor (75) with the computer (64), then fix the computer (64) on the handlebar post (10) by using the screws.
- 2) Put the end cap (85) onto the fixed bar.

CONTROL PANEL



SUPPORT DEVICES

Support iOS devices:

- iPod touch (5th generation)
- iPod touch (4th generation)
- iPod touch (3rd generation)
- iPhone 5S
- iPhone 5C
- iPhone 5
- iPhone 4S
- iPhone 4
- iPhone 3GS
- iPad Air
- iPad 4
- iPad 3
- iPad 2
- iPad
- iPad Min
- Support iOS 5.0 or above

Support Android devices:

- Android tablet OS 4.0 or above
- Android tablet resolution 1280X800 pixels
- Android phone OS 2.2 or above
- Android phone resolution:
 - 1920X1080 pixels
 - 1280X800 pixels
 - 1280X760 pixels
 - 800X480 pixels

“Made for iPod,” “Made for iPhone,” and “Made for iPad” mean that an electronic accessory has been designed to connect specifically to iPod, iPhone, or iPad, respectively, and has been certified by the developer to meet Apple performance standards. Apple is not responsible for the operation of this device or its compliance with safety and regulatory standards. Please note that the use of this accessory with iPod, iPhone, or iPad may affect wireless performance.

iPad, iPhone, iPod, iPod classic, iPod nano, iPod shuffle, and iPod touch are trademarks of Apple Inc., registered in the U.S. and other countries.

DISPLAY FUNCTIONS

ITEM	DESCRIPTION
TIME	Workout time displayed during exercise. Range 0:00 ~ 99:59
SPEED	Workout speed displayed during exercise. Range 0.0 ~ 99.9
DISTANCE	Workout distance displayed during exercise. Range 0.0 ~ 99.9
CALORIES	Burned calories during workout display. Range 0 ~ 999
PULSE	Pulse bpm displayed during exercise. Pulse alarm when over preset target pulse.
RPM	Rotation per minute Range 0 ~ 999
WATT	Workout power consumption In Watt Program mode, computer will remain preset watt value (setting range 0~350)
MANUAL	Manual mode workout.
PROGRAM	Beginner, Advance, and Sporty PROGRAM selection.
CARDIO	Target HR training mode.

KEYS

ITEM	DESCRIPTION
Up	<ul style="list-style-type: none"> • Increase resistance level • Setting selection.
Down	<ul style="list-style-type: none"> • Decrease resistance level • Setting selection.
Enter	<ul style="list-style-type: none"> • Confirm setting or selection.
Reset	<ul style="list-style-type: none"> • Hold on pressing for 2 seconds, computer will reboot and start from user setting. • Reverse to main menu during presetting workout value or stop mode.
Start/ Stop	<ul style="list-style-type: none"> • Start or Stop workout.

Recovery	<ul style="list-style-type: none"> • Test heart rate recovery status.
Body fat	<ul style="list-style-type: none"> • Test body fat% and BMI.

OPERATION

POWER ON

Plug in power supply, computer will power on and display all segments on LCD for 2 seconds. After 4 minutes without pedaling or pulse input, console will enter into power saving mode.

Press any key may wake the console up.

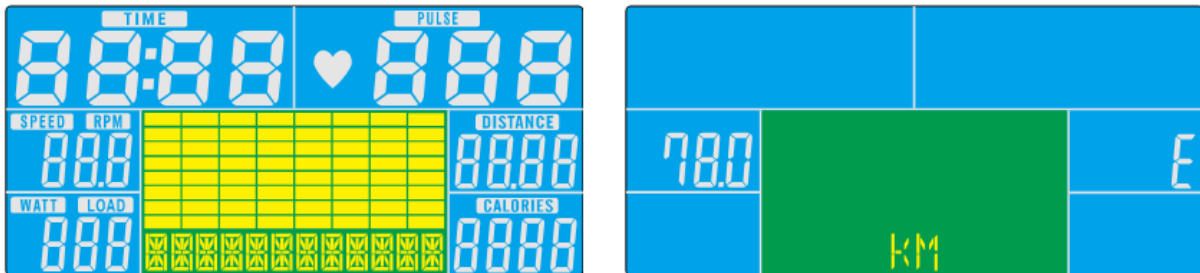

WORKOUT SELECTION

Press UP and Down to select workout Manual → Beginner → Advance → Sporty → Cardio → Watt

MANUAL MODE

Press START in main menu may start workout in manual mode.



- 1) Press UP or DOWN to select workout program, choose Manual and press ENTER to confirm.
- 2) Press UP or DOWN to preset TIME, DISTANCE, CALORIES, PULSE and press ENTER to confirm.
- 3) Press START/STOP keys to start workout. Press UP or DOWN to adjust load level.
- 4) Press START/STOP keys to pause workout. Press RESET to reverse to main menu.

BEGINNER MODE



- 1) Press UP or DOWN to select workout program, choose Beginner mode and press ENTER to confirm.
- 2) Press UP or DOWN to preset TIME.

- 3) Press START/STOP key to start workout. Press UP or DOWN to adjust load level.
- 4) Press START/STOP key to pause workout. Press RESET to reverse to main menu.

ADVANCE MODE



- 1) Press UP or DOWN to select workout program, choose Advance mode and press ENTER to confirm.
- 2) Press UP or DOWN to preset TIME.
- 3) Press START/STOP key to start workout. Press UP or DOWN to adjust load level.
- 4) Press START/STOP key to pause workout. Press RESET to reverse to main menu.

SPORTY MODE

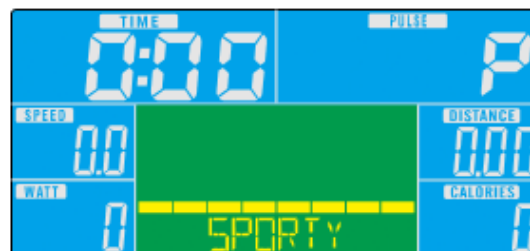

- 1) Press UP or DOWN to select workout program, choose Sporty mode and press ENTER to confirm.
- 2) Press UP or DOWN to preset TIME.
- 3) Press START/STOP key to start workout. Press UP or DOWN to adjust load level.
- 4) Press START/STOP key to pause workout. Press RESET to reverse to main menu.

CARDIO MODE

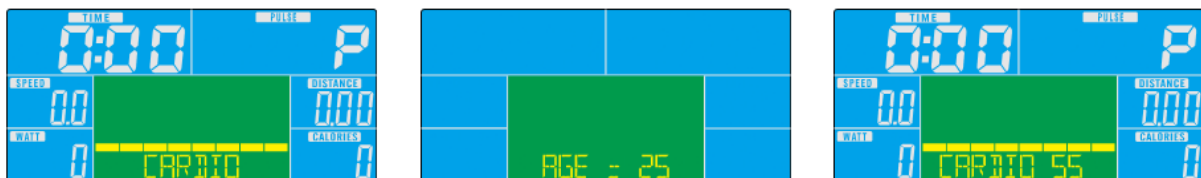

- 1) Press UP or DOWN to select workout program, choose H.R.C. and press ENTER to confirm.
- 2) Press UP or Down to select 55%.75%.90% or TAG (TARGET H.R.) (default: 100).
- 3) Press UP or DOWN to preset workout TIME.
- 4) Press START/STOP key to start or stop workout. Press RESET to reverse to main menu.

WATT MODE



- 1) Press UP or DOWN to select workout program, choose WATT and press ENTER to confirm.
- 2) Press UP or DOWN to preset WATT target. (default: 120)
- 3) Press UP or DOWN to preset TIME.
- 4) Press START/STOP key to start workout. Press UP or DOWN to adjust Watt level.
- 5) Press START/STOP key to pause workout. Press RESET to reverse to main menu.

iConsole+ APP

Turn on Bluetooth on tablet, search for console device and press connect. (password: 0000)

Turn on iconsole+ app on tablet, and start workout with tablet.



NOTE:

1. Once console is connect to tablet via Bluetooth, the console will power off.
2. Please exit iConsole app and turn off the Bluetooth from iPad, then the console will power on again.

TERMS AND CONDITIONS OF WARRANTY, WARRANTY CLAIMS

General Conditions of Warranty and Definition of Terms

All Warranty Conditions stated hereunder determine Warranty Coverage and Warranty Claim Procedure. Conditions of Warranty and Warranty Claims are governed by Act No. 40/1964 Coll. Civil Code, Act No. 513/1991 Coll., Commercial Code, and Act No. 634/1992 Coll., Consumer Protection Act, as amended, also in cases that are not specified by these Warranty rules.

The seller is SEVEN SPORT s.r.o. with its registered office in Borivojova Street 35/878, Prague 13000, Company Registration Number: 26847264, registered in the Trade Register at Regional Court in Prague, Section C, Insert No. 116888.

According to valid legal regulations it depends whether the Buyer is the End Customer or not.

“The Buyer who is the End Customer” or simply the “End Customer” is the legal entity that does not conclude and execute the Contract in order to run or promote his own trade or business activities.

“The Buyer who is not the End Customer” is a Businessman that buys Goods or uses services for the purpose of using the Goods or services for his own business activities. The Buyer conforms to the General Purchase Agreement and business conditions to the extent specified in the Commercial Code.

These Conditions of Warranty and Warranty Claims are an integral part of every Purchase Agreement made between the Seller and the Buyer. All Warranty Conditions are valid and binding, unless otherwise specified in the Purchase Agreement, in the Amendment to this Contract or in another written agreement.

Warranty Conditions

Warranty Period

The Seller provides the Buyer a 24 months Warranty for Goods Quality, unless otherwise specified in the Certificate of Warranty, Invoice, Bill of Delivery or other documents related to the Goods. The legal warranty period provided to the Consumer is not affected.

By the Warranty for Goods Quality, the Seller guarantees that the delivered Goods shall be, for a certain period of time, suitable for regular or contracted use, and that the Goods shall maintain its regular or contracted features.

The Warranty does not cover defects resulting from (if applicable):

- User's fault, i.e. product damage caused by unqualified repair work, improper assembly, insufficient insertion of seat post into frame, insufficient tightening of pedals and cranks
- Improper maintenance
- Mechanical damages
- Regular use (e.g. wearing out of rubber and plastic parts, moving mechanisms, joints etc.)
- Unavoidable event, natural disaster
- Adjustments made by unqualified person
- Improper maintenance, improper placement, damages caused by low or high temperature, water, inappropriate pressure, shocks, intentional changes in design or construction etc.

Warranty Claim Procedure

The Buyer is obliged to check the Goods delivered by the Seller immediately after taking the responsibility for the Goods and its damages, i.e. immediately after its delivery. The Buyer must check the Goods so that he discovers all the defects that can be discovered by such check.

When making a Warranty Claim the Buyer is obliged, on request of the Seller, to prove the purchase and validity of the claim by the Invoice or Bill of Delivery that includes the product's serial number, or eventually by the documents without the serial number. If the Buyer does not prove the validity of the Warranty Claim by these documents, the Seller has the right to reject the Warranty Claim.

If the Buyer gives notice of a defect that is not covered by the Warranty (e.g. in the case that the Warranty Conditions were not fulfilled or in the case of reporting the defect by mistake etc.), the Seller is eligible to require a compensation for all the costs arising from the repair. The cost shall be calculated according to the valid price list of services and transport costs.

If the Seller finds out (by testing) that the product is not damaged, the Warranty Claim is not accepted. The Seller reserves the right to claim a compensation for costs arising from the false Warranty Claim.

In case the Buyer makes a claim about the Goods that is legally covered by the Warranty provided by the Seller, the Seller shall fix the reported defects by means of repair or by the exchange of the damaged part or product for a new one. Based on the agreement of the Buyer, the Seller has the right to exchange the defected Goods for a fully compatible Goods of the same or better technical characteristics. The Seller is entitled to choose the form of the Warranty Claim Procedures described in this paragraph.

The Seller shall settle the Warranty Claim within 30 days after the delivery of the defective Goods, unless a longer period has been agreed upon. The day when the repaired or exchanged Goods is handed over to the Buyer is considered to be the day of the Warranty Claim settlement. When the Seller is not able to settle the Warranty Claim within the agreed period due to the specific nature of the Goods defect, he and the Buyer shall make an agreement about an alternative solution. In case such agreement is not made, the Seller is obliged to provide the Buyer with a financial compensation in the form of a refund.



SEVEN SPORT s.r.o.

Registered Office:

Borivojova 35/878, 130 00 Praha 3, Czech Republic

Headquarters:

Delnicka 957, 749 01 Vitkov, Czech Republic

Warranty & Service Centre: Cermenska 486, 749 01 Vitkov, Czech Republic
CRN: 26847264
VAT ID: CZ26847264
Phone: +420 556 300 970
E-mail: eshop@insportline.cz
reklamace@insportline.cz
servis@insportline.cz
Web: www.insportline.cz

SK

INSPORTLINÉ s.r.o.

Headquarters, Warranty & Service centre: Elektricna 6471, 911 01 Trencin, Slovakia
CRN: 36311723
VAT ID: SK2020177082
Phone: +421(0)326 526 701
E-mail: objednavky@insportline.sk
reklamacie@insportline.sk
servis@insportline.sk
Web: www.insportline.sk

Date of Sale:

Stamp and Signature of Seller: