

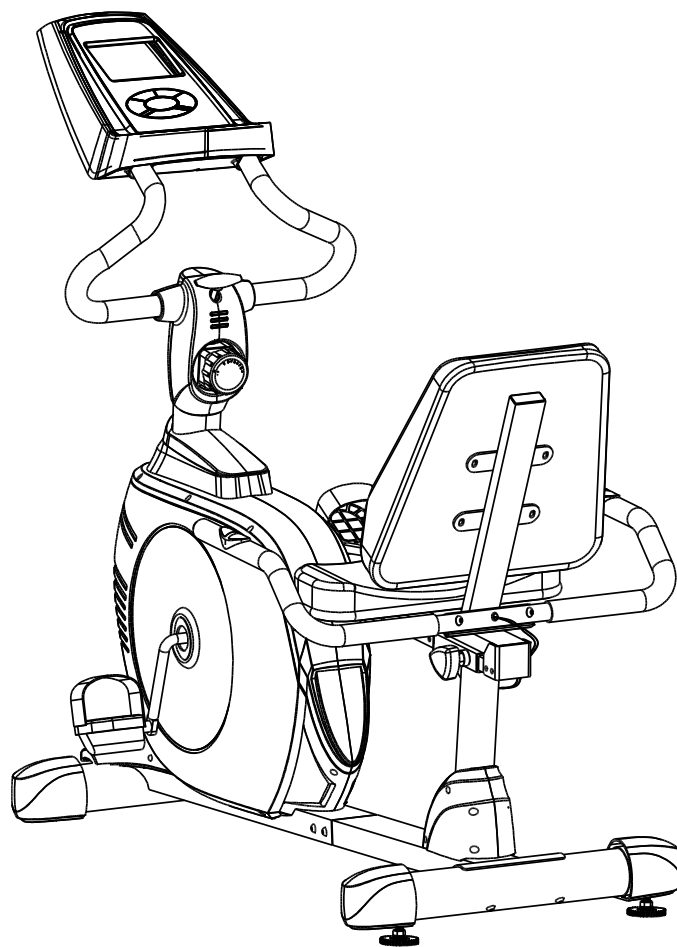

USER MANUAL – EN
IN 8245 Recumbent inSPORTline Nahary



CONTENTS

- IMPORTANT SAFETY INSTRUCTIONS 3
- OVERVIEW DRAWING..... 4
- PARTS LIST 5
 - HARDWARE PACKING LIST 7
 - TOOLS..... 8
- ASSEMBLY INSTRUCTIONS 8
 - STEP 1: REAR MAIN FRAME INSTALLATION 8
 - STEP 2: FRONT AND REAR STABILIZERS INSTALLATION..... 9
 - STEP 3: RIGHT/LEFT FOOT PEDALS AND BACK/SEAT SUPPORT BRACKET INSTALLATION 10
 - STEP 4: FRONT POST AND FRONT POST COVER INSTALLATION..... 11
 - STEP 5: SEAT/BACK CUSHIONS AND REAR HANDLEBAR INSTALLATION..... 12
 - STEP 6: FRONT HANDLEBAR, FRONT/REAR DECORATIVE COVERS FOR FRONT POST, AND COMPUTER INSTALLATION..... 13
- OPERATING THE COMPUTER..... 14
- ADJUSTMENTS 15
 - ADJUSTING THE ADJUSTABLE LEVELER 15
 - ADJUSTING THE FRONT HANDLEBAR..... 16
 - ADJUSTING THE TENSION CONTROL KNOB 16
 - ADJUSTING THE SEAT FORWARD OR BACK..... 16
- MAINTENANCE 17
 - CLEANING..... 17
 - STORAGE..... 17
- TROUBLESHOOTING 17
- WARM UP AND COOL DOWN ROUTINE..... 17
- TERMS AND CONDITIONS OF WARRANTY, WARRANTY CLAIMS..... 19



IMPORTANT: Read all instructions carefully before using this product. Retain this owner's manual for future reference.

The specifications of this product may vary from this photo, subject to change without notice.

IMPORTANT SAFETY INSTRUCTIONS

Basic precautions should always be followed, including the following important safety instructions when using this equipment. Read all instructions before using this equipment.

1. Read all instructions and follow it carefully before using this equipment. Make sure the equipment is properly assembled and tightened before use.
2. Before exercise, in order to avoid injuring the muscle, warm-up exercises are recommended.
3. Please make sure all parts are not damaged and fixed well before use. This equipment should be placed on a flat surface when using. Using a mat or other covering material on the ground is recommended.
4. Please wear proper clothes and shoes when using this equipment; do not wear clothes that may catch any part of the equipment; remember to tighten the pedaling straps.
5. Do not attempt any maintenance or adjustments other than those described in this manual. Should any problems arise, discontinue use and consult your local dealer.
6. Do not use the equipment outdoors.
7. This equipment is for household use only. It is not a commercial model.
8. Only one person at a time should use this equipment.
9. If you feel any chest pains, nausea, dizziness, or short of breath, you should stop exercising immediately and consult your physician before continuing.
10. Care should be taken in mounting or dismounting the equipment.
11. Do not allow children to use or play on the equipment. Keep children and pets away from the equipment while in use. This machine is designed for adults use only. The minimum free space required for safe operation is not less than two meters.
12. The maximum weight capacity for this product is 140 kgs.
13. Class - HC (according to EN ISO 20957) for home use.

WARNING: Before beginning any exercise program consult your physician. This is especially important for the people who are over 35 years old or who have pre-existing health problems. Read all instructions before using any fitness equipment.

CAUTION: Read all instructions carefully before operating this product. Retain this Owner's Manual for future reference.

OVERVIEW DRAWING

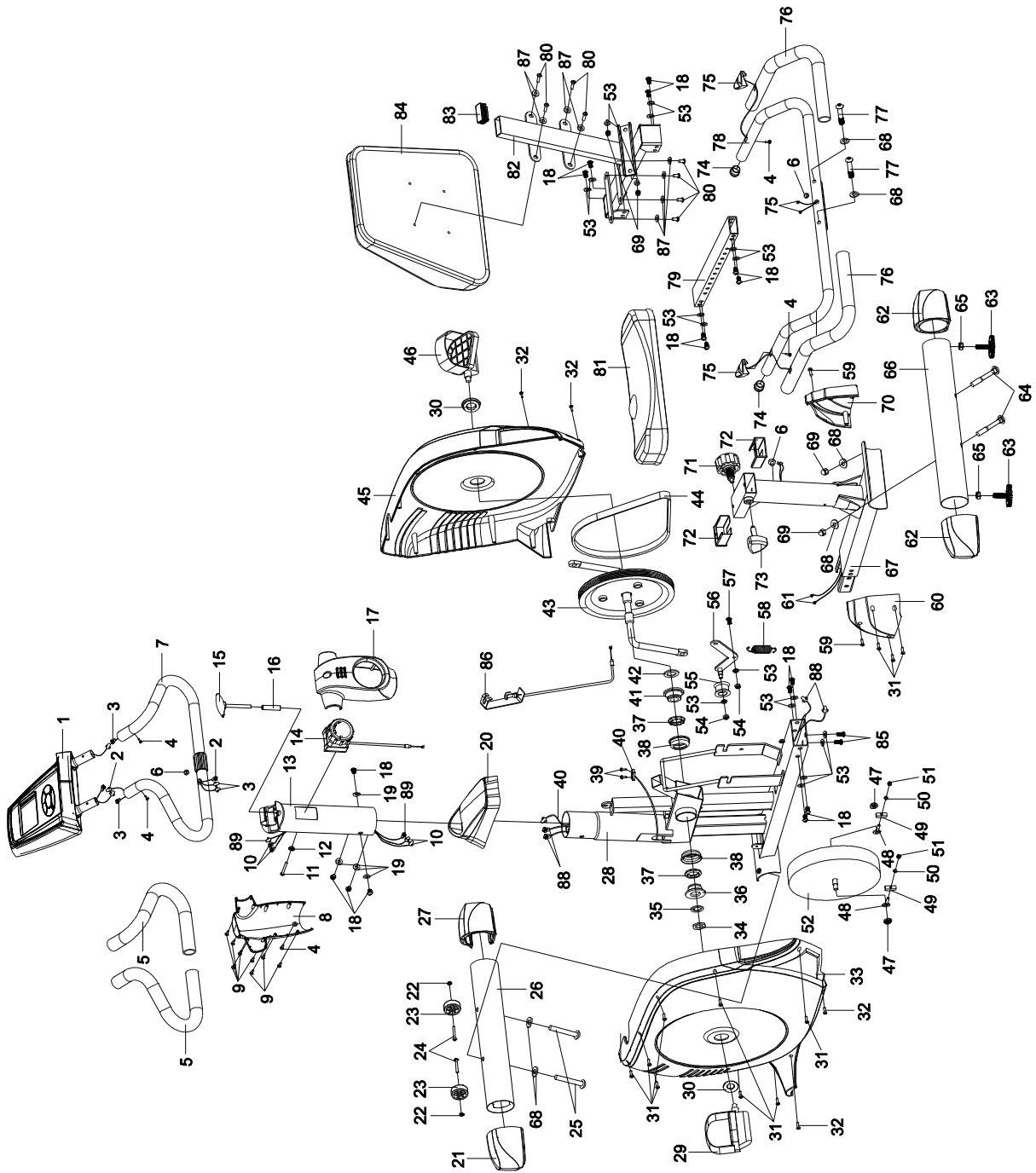





PARTS LIST

No.	Description	Qty
001	Computer (XLG-903)	1
002	Extension Sensor Wire B L=500mm	1
003	Extension Hand Pulse Sensor Wire D L=500mm	2
004	Screw ST4.2x20mm	5
005	Front Handlebar Foam Grip Ø33xØ27x500	2
006	Wire Plug Ø12.1	3
007	Front Handlebar Ø25x1.5	1
008	Front Decorative Cover for Front Post	1
009	Screw ST2.9x16mm	8
010	Extension Hand Pulse Sensor Wire C L=350mm	1
011	Bolt M5x30	1
012	Big Curve Washer Ø5	1
013	Front Post Ø76x1.5	1
014	Tension Control Knob L=170mm	1
015	Front Handlebar T-Knob M8x75	1
016	Spacer Ø12x1.5x50	1
017	Rear Decorative Cover for Front Post	1
018	Bolt M8x15mm	16
019	Curve Washer Ø8	4
020	Front Post Cover	1
021	Front Left Stabilizer End Cap	1
022	Nylon Nut M6	2
023	Transport Wheel Ø45x19	2
024	Bolt M6x40	2
025	Bolt M8x90mm	2
026	Front Stabilizer Ø76x1.5	1
027	Front Right Stabilizer End Cap	1
028	Front Main Frame 80x40x2	1
029	Left Foot Pedal (YH-30X)	1
030	Cover Cap Ø40xØ25x10	2
031	Screw ST4.2x25mm	11
032	Phillips Self Tapping Screw ST4.2x25mm	4
033	Left Shroud	1
034	Hexagon Nut 7/8"	1
035	Washer Ø34.5xØ23x2.5	1
036	Bearing Nut II 7/8"	1

037	Bearing	2
038	Bearing Cup	2
039	Screw ST2.9x12mm	2
040	Sensor with Wire L=750mm	1
041	Bearing Nut I 15/16"	1
042	Washer Ø40xØ24x3	1
043	Belt Pulley with Crank Ø260 J6	1
044	Belt PJ390 J6	1
045	Right Shroud	1
046	Right Foot Pedal (YH-30X)	1
047	Nut M10x1.0	2
048	Eyebolt M6x36	2
049	Tension Bracket	2
050	Spring Washer Ø6	2
051	Nut M6	2
052	Flywheel Ø250	1
053	Washer Ø16xØ8x1.5t	18
054	Nylon Nut M8	2
055	Idle Wheel	1
056	Idle Wheel Bracket	1
057	Bolt M8x20mm	1
058	Spring Ø18x92xØ3	1
059	Screw ST4.8x20mm	2
060	Left Rear Main Frame Cover	1
061	Hand Pulse Sensor Extension Wire A L=1000mm	1
062	Rear Stabilizer End Cap	2
063	Adjustable Leveler M10	2
064	Carriage Bolt M8x90mm	2
065	Nut M10	2
066	Rear Stabilizer Ø76x1.5	1
067	Rear Main Frame 80x40x1.5	1
068	Big Curve Washer Ø20xØ8x1.5t	6
069	Cap Nut M8	4
070	Right Rear Main Frame Cover	1
071	Round Knob M16x1.5	1
072	Bushing	2
073	Triangle Knob M12x58	1
074	Rear Handlebar Round End Cap	2

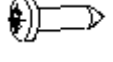
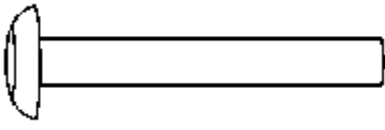
075	Hand Pulse Sensor with Wire L=750mm	2
076	Rear Handlebar Foam Grip Ø27xØ33x600	2
077	Bolt M8x45mm	2
078	Rear Handlebar Ø76x1.5	1
079	Seat Sliding Tube 53x23x2	1
080	Bolt M6x15	8
081	Seat Cushion 420x250x60	1
082	Back and Seat Support Bracket 53x23x2	1
083	Backrest and Seat Support Bracket End Cap	1
084	Back Cushion x400x430x90	1
085	Bolt M8x30mm	2
086	Tension Cable L=950mm	1
087	Washer Ø6xØ18	8
088	Extension Hand Pulse Sensor Wire B L=1000mm	1
089	Extension Sensor Wire A L=350mm	1

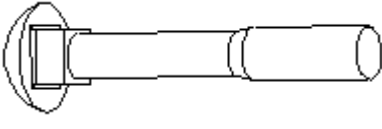
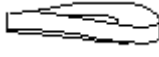
HARDWARE PACKING LIST

 (4) Screw ST4.2x20mm 3 PCS	 (9) Screw ST2.9x16mm 8 PCS	 (25) Bolt M8x90mm 2 PCS
 (53) Washer Ø16xØ8x1.5t 2 PCS	 (64) Carriage Bolt M8x90mm 2 PCS	 (68) Big Curve Washer Ø20xØ8x1.5t 6 PCS
 (69) Cap Nut M8 4 PCS	 (77) Bolt M8x45mm 2 PCS	

TOOLS

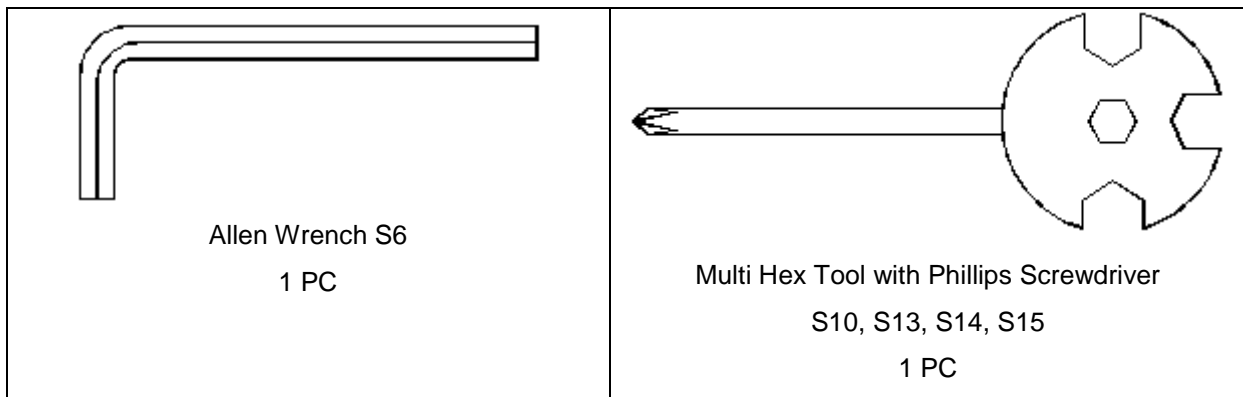

ASSEMBLY INSTRUCTIONS

STEP 1: REAR MAIN FRAME INSTALLATION

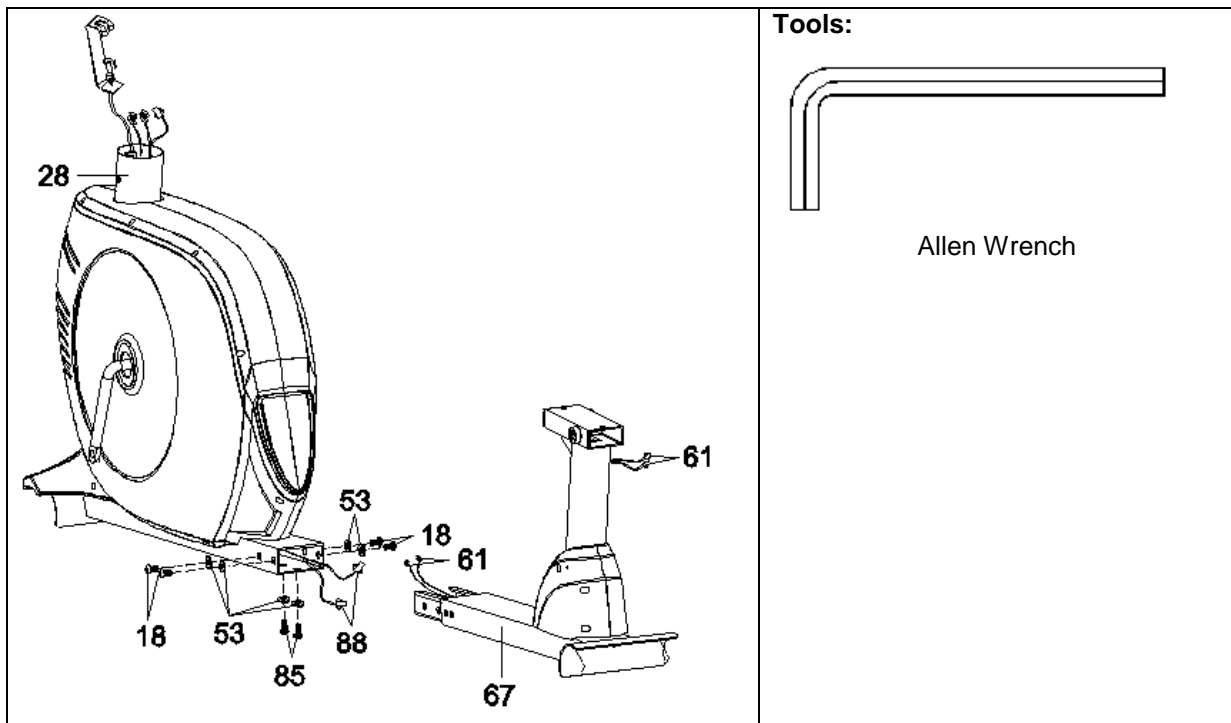

Remove two M8x30mm Bolts (85), four M8x15mm Bolts (18), and six $\text{\O}16\text{x}\text{\O}8\text{x}1.5\text{t}$ Washers (53) from the Rear Main Frame (67). Remove bolts with the S6 Allen Wrench provided.



Connect the Hand Pulse Sensor Extension Wire A (61) from the Rear Main Frame (67) to the Hand Pulse Sensor Extension Wire B (88) from the Front Main Frame (28).

Attach the Rear Main Frame (67) into the Front Main Frame (28) with two M8x30mm Bolts (85), four M8x15mm Bolts (18), and six $\text{\O}16\text{x}\text{\O}8\text{x}1.5\text{t}$ Washers (53) that were removed. Tighten bolts with the S6 Allen Wrench provided.

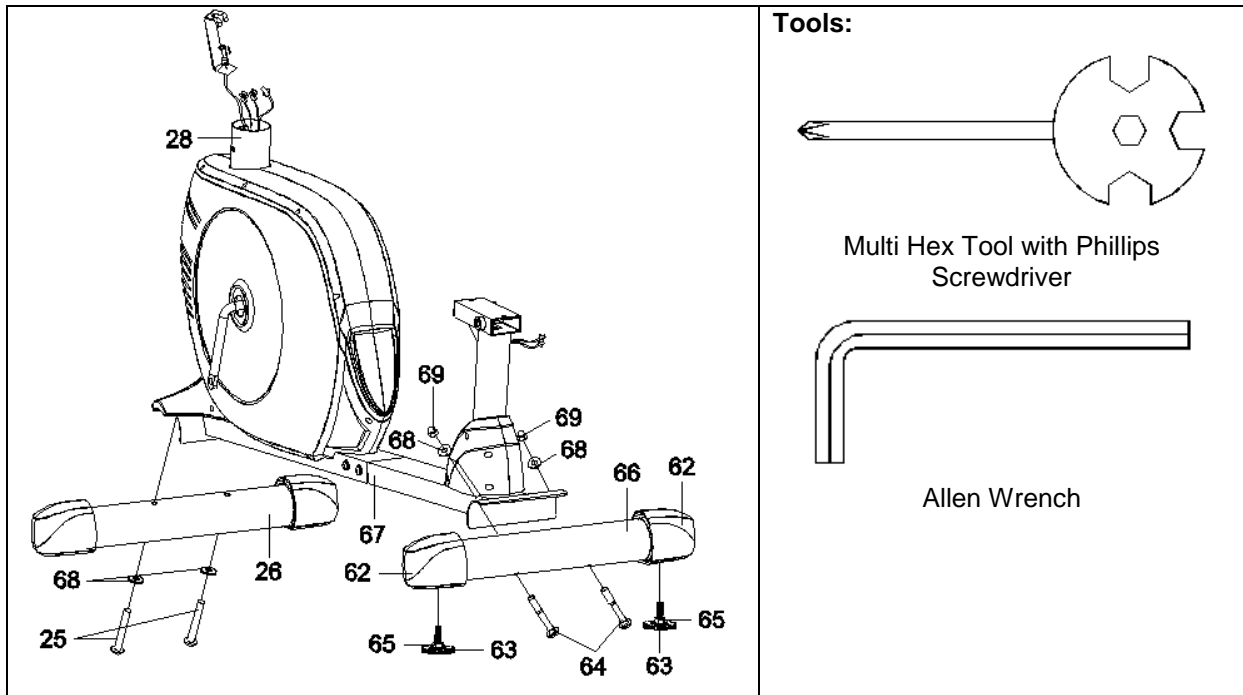
STEP 2: FRONT AND REAR STABILIZERS INSTALLATION

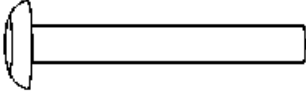
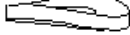
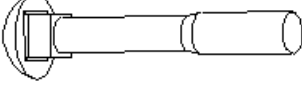

Hardware:

 (25) Bolt M8x90mm 2 PCS	 (68) Big Curve Washer Ø20xØ8x1.5t 4 PCS	 (64) Carriage Bolt M8x90mm 2 PCS	 (69) Cap Nut M8 2 PCS
---	---	---	---

Position the Front Stabilizer (26) in front of Front Main Frame (28) and align bolt holes.

Attach the Front Stabilizer (26) onto the front curve of the Front Main Frame (28) with two M8x90mm Bolts (25) and two Ø20xØ8x1.5t Big Curve Washers (68). Tighten bolts and curve washers with the S6 Allen Wrench provided.

Position the Rear Stabilizer (66) behind the Rear Main Frame (67) and align bolt holes.

Attach the Rear Stabilizer (66) onto the rear curve of the Rear Main Frame (67) with two M8x90mm Carriage Bolts (64), two Ø20xØ8x1.5t Big Curve Washers (68), and two M8 Cap Nuts (69). Tighten cap nuts and bolts with the Multi hex Tool with Phillips Screwdriver provided.

Install two M10 Adjustable Levelers (63) with two M10 Nuts (65) onto the Rear Stabilizer (66).

STEP 3: RIGHT/LEFT FOOT PEDALS AND BACK/SEAT SUPPORT BRACKET INSTALLATION

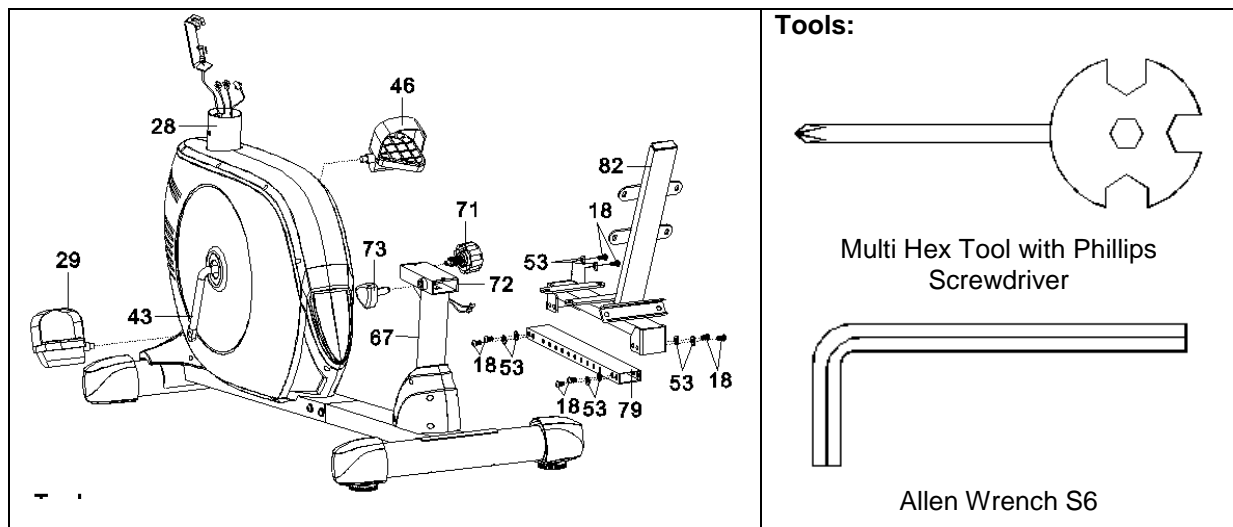

The Cranks, Foot Pedals, Pedal Shafts and Pedal Straps are marked “R” for Right and “L” for Left.

Insert the pedal shaft of Left Foot Pedal (29) into threaded hole in the left Crank (43). Turn the pedal shaft by hand in the counter-clockwise direction until snug.

Note: DO NOT turn the pedal shaft in the clockwise direction, doing so will strip the threads.

Tighten the pedal shaft of Left Foot Pedal (29) with the Multi Hex Tool with Phillips Screwdriver provided.

Insert pedal shaft of Right Foot Pedal (46) into threaded hole in right Crank (43). Turn the pedal shaft by hand in the clockwise direction until snug.

Tighten pedal shaft of Right Foot Pedal (43) with the Multi Hex Tool with Phillips Screwdriver provided.

Remove eight M8x15mm Bolts (18), eight Ø16xØ8x1.5t Washers (53), and the Seat Sliding Tube (79) from the Back and Seat Support Bracket (82). Remove bolts with the S6 Allen Wrench provided.

Insert the Seat Sliding Tube (79) into the Bushings (72) of the Rear Main Frame (67).

Attach the Seat Sliding Tube (79) to the Back and Seat Support Bracket (82) with eight M8x15mm Bolts (18) and eight Ø16xØ8x1.5t Washers (53) that were removed. Tighten bolts with the S6 Allen Wrench provided.

Adjust the seat position and insert the Round Knob (71) and Triangle Knob (73). Turn the Round Knob (71) and Triangle Knob (73) in the clockwise direction to tighten.

STEP 4: FRONT POST AND FRONT POST COVER INSTALLATION

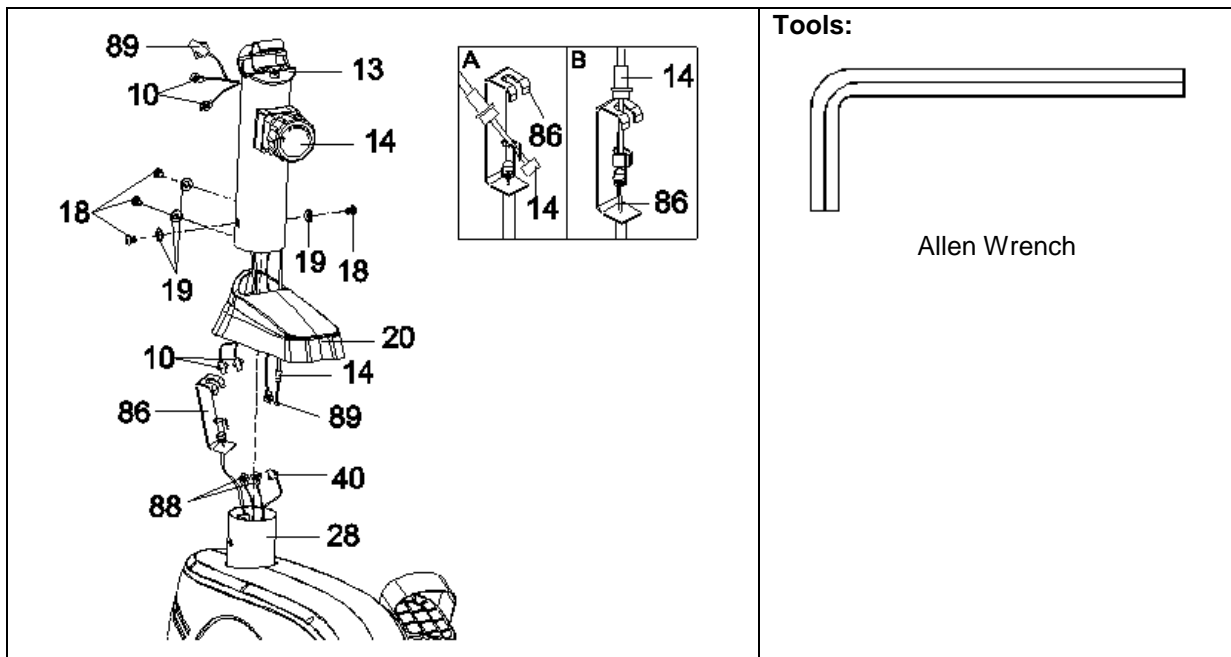

Remove four M8x15mm Bolts (18) and four Ø8 Curve Washers (19) from the Front Main Frame (28). Remove bolts and curve washers with the S6 Allen Wrench provided.

Slide the Front Post Cover (20) up to the Front Post (13).

Put the cable end of resistance cable of Tension Control Knob (14) into the spring hook of Tension Cable (86) as shown in drawing A of figure 4. Pull the resistance cable of Tension Control Knob (14) up and force it into the gap of metal bracket of Tension Cable (86) as shown in drawing B of figure 4.

Connect the Extension Hand Pulse Sensor Wire B (88) and Sensor Wire (40) from the Front Main Frame (28) to the Extension Hand Pulse Sensor Wire C (10) and Extension Sensor Wire A (89) from the Front Post (13).



Insert the Front Post (13) onto the tube of the Front Main Frame (28) and secure with four M8x15mm Bolts (18) and four Ø8 Curve Washers (19) that were removed. Tighten bolts and curve washers with the S6 Allen Wrench provided.

Slide the Front Post Cover (20) down to the Front Post (13).

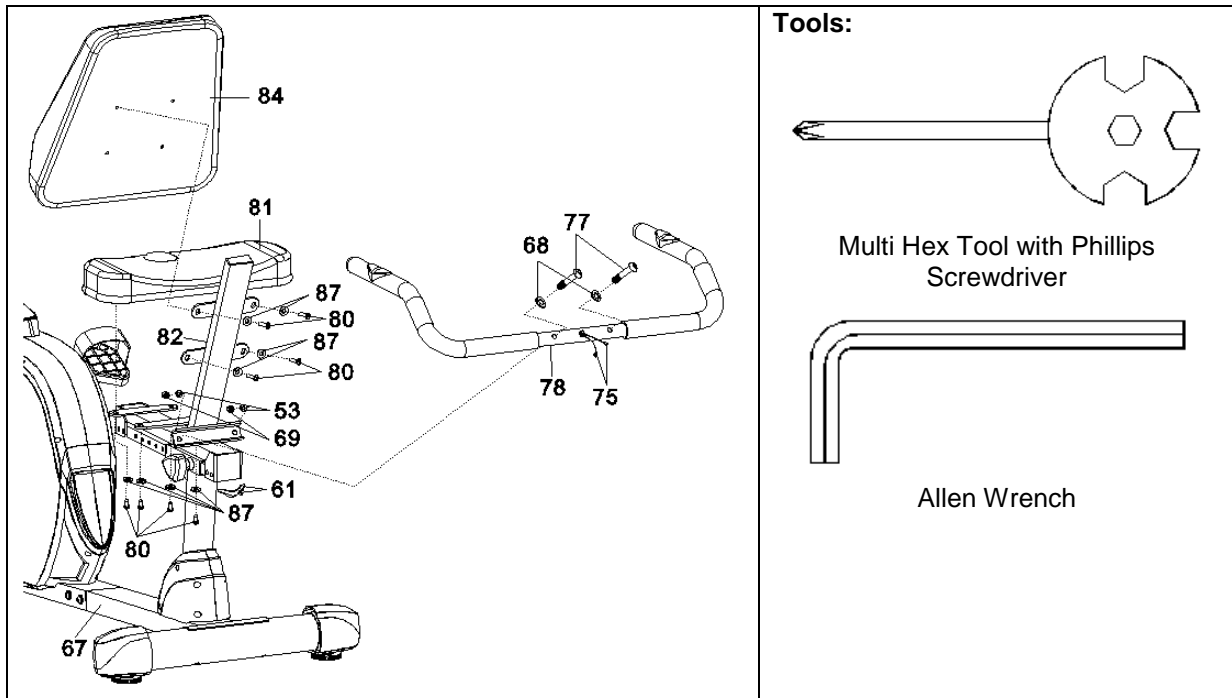
STEP 5: SEAT/BACK CUSHIONS AND REAR HANDLEBAR INSTALLATION

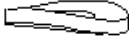

Hardware:

 <p>(77) Bolt M8x45mm 2 PCS</p>	 <p>(68) Big Curve Washer Ø20xØ8x1.5t 2 PCS</p>	 <p>(53) Washer Ø16xØ8x1.5t 2 PCS</p>	 <p>(69) Cap Nut M8 2 PCS</p>
--	--	--	--

Remove eight M6x15mm Bolts (80) and eight Ø6xØ18 Washers (87) from the back of the Seat and Back Cushions (81, 84). Remove bolts with the Multi Hex Tool with Phillips Screwdriver provided. Then attach the Seat and Back Cushions (81, 84) onto the Back and Seat Support Bracket (82) with eight M6x15 Bolts (80) and eight Ø6xØ18 Washers (87) that were removed. Tighten bolts with the Multi Hex Tool with Phillips Screwdriver provided.



Attach the Rear Handlebar (78) onto the Back and Seat Support Bracket (82) with two M8x45mm Bolts (77), two Ø20xØ8x1.5t Big Curve Washers (68), two Ø16xØ8x1.5t Washers (53), and two M8 Cap Nuts (69). Tighten nuts and bolts with the Multi Hex Tool with Phillips Screwdriver and S6 Allen Wrench provided.

Connect the Hand Pulse Sensor Extension Wire A (61) from the Rear Main Frame (67) to the Hand Pulse Sensor with Wires (75) from the Rear Handlebar (78).

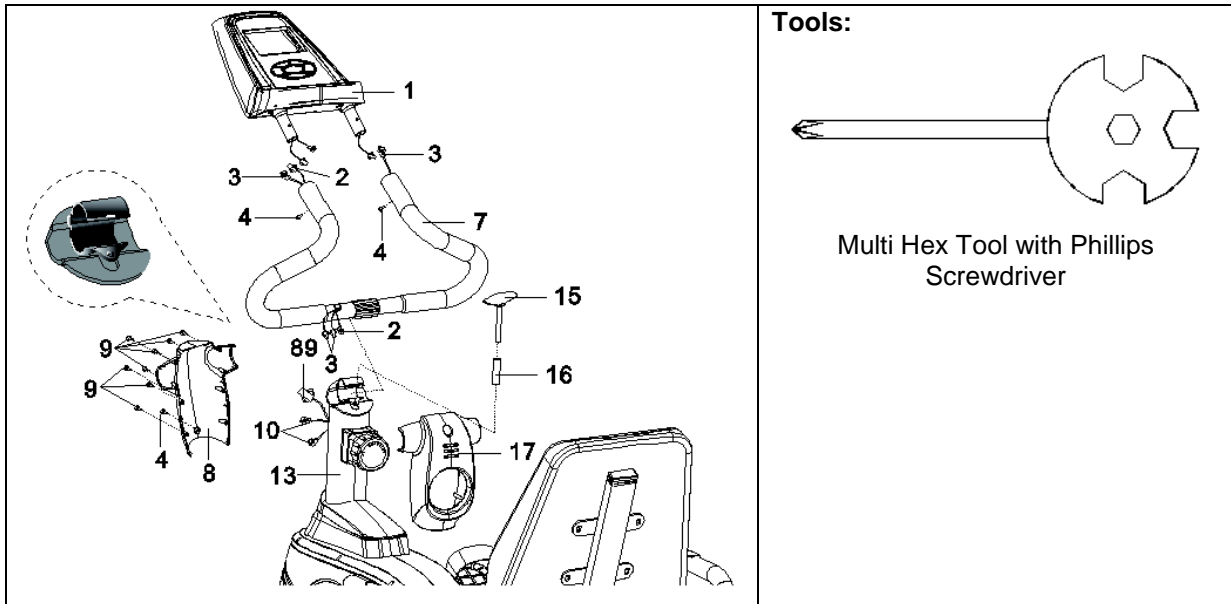
STEP 6: FRONT HANDLEBAR, FRONT/REAR DECORATIVE COVERS FOR FRONT POST, AND COMPUTER INSTALLATION



Hardware:

 (4) Screw ST4.2x20mm 3 PCS	 (9) Screw ST2.9x16mm 8 PCS
--	--

Place the Front Handlebar (7) through clamp on the top end of the Front Post (13). Connect the Extension Hand Pulse Sensor Wire C (10) and Extension Sensor Wire A (89) from the Front Post (13) to the Extension Hand Pulse Sensor Wires D (3) and Extension Sensor Wire B (2) from the Front Handlebar (7). Hold the Front Handlebar (7) in desired position and fasten Front/Rear Decorative Covers for Front Post (8, 17), M8x75 Front Handlebar T-Knob (15), and Ø12x1.5x50 Spacer (16) onto clamp and tighten Front/Rear Decorative Covers for Front Post (8, 17) with one ST4.2x20mm Screw (4) and eight ST2.9x16mm Screws (9). Tighten screws with the Multi Hex Tool with Phillips Screwdriver provided.

NOTE: M8x75 Front Handlebar T-Knob should be tightly secured before using.

Connect the Extension Hand Pulse Sensor Wires D (3) and Extension Sensor Wire B (2) to the wires that come from the Computer (1). Then install the Computer (1) to the Front Handlebar (7) by inserting the Computer (1) into the Front Handlebar (7), using two ST4.2x20mm Screws (4). Tighten screws with the Multi Hex Tool with Phillips Screwdriver provided.

OPERATING THE COMPUTER



SPECIFICATIONS

TIME	0:00-99:59 MIN:SEC
SPEED	0.0-99.9 KM/H
DIS (DISTANCE)	0.0-99.9 KM
CAL (CALORIES)	0.0-999 KCAL
PULSE	40-200 BEATS/MIN

USING YOUR COMPUTER

The computer can be activated by pressing the buttons or by pedaling. If you leave the equipment idle for approximately 4 minutes, the power will turn off automatically.

BUTTON FUNCTIONS

MODE: Press the MODE button to select each function of computer.

Press and hold the MODE button for 4 seconds, all data values will clear to zero.

SET: Press the SET button to set data values of TIME, DIS. (DISTANCE), or CAL. (CALORIES) for target pre-setting.

RESET: Press RESET button to clear data values of TIME, DIS. (DISTANCE), or CAL. (CALORIES) to zero for target pre-setting.

RECOVERY: The Pulse Recovery is for personal orientation and compares the approximate pulse rate before and after training. You will notice that your fitness will improve with regular exercise. The Pulse Recovery feature is to be used directly after your workout. To use this function:

- 1) Grip the handlebar sensors with both your hands during exercise.
- 2) Press the RECOVERY button.
- 3) The time will countdown from 60 to 0 seconds. Grip the handlebar sensors with both your hands.
- 4) Your personal fitness Pulse Recovery level will appear on the display. When countdown is complete, the Pulse Recovery grade will be displayed.

Your ratings for Pulse Recovery are as follows:

F1 = Excellent F4 = Below Average

F2 = Good F5 = Not Good

F3 = Fair F6 = Poor

COMPUTER FUNCTIONS

SCAN: Press the MODE button until the screen displays SCAN, the computer will automatically scan the functions every 5 seconds.

TIME: Displays your elapsed workout time in minutes and seconds. You may also pre-set target time in STOP mode before training. To set TIME press the MODE button until you see the TIME begin blinking. Press the SET button to change the time, each time you press the SET button TIME should change by 1 minute. Press the RESET button to clear the target time to zero. The pre-set target time range is from 00:00 to 99:00 minutes. Once you pre-set target time and then start to exercise, time starts counting down from pre-set target time to 0:00 per 1 second backward. When the pre-set target time counts down to 0:00, time will start to count up and the computer will begin beep to remind you.

SPEED: Display the current training speed.

DIS. (DISTANCE): Displays the accumulative distance traveled during workout. You may also pre-set target distance in STOP mode before training. To set DISTANCE press the MODE button until you see the DISTANCE begin blinking. Press the SET button to change the distance, each time you press the SET button DISTANCE should change by 0.1 km. Press the RESET button to clear the target distance to zero. The pre-set target distance range is from 0.00 to 99.9 km. Once you pre-set target distance and then start to exercise, distance starts counting down from pre-set target distance to 0.00. When the pre-set target distance counts down to 0.00, distance will start to count up and the computer will begin beep to remind you.

CAL. (CALORIES): Displays the total accumulated calories burned during workout. You

May also pre-set target calories in STOP mode before training. To set CALORIES press the MODE button until you see the CALORIES begin blinking. Press the SET button to change the calories, each time you press the SET button CALORIES change by 1 calorie. Press the RESET button to clear the target calories to zero. The pre-set target calories range is from 0 to 999 calories. Once you pre-set target calories and then start to exercise, calories start counting down from pre-set target calories to 0. When the pre-set target calories count down to 0, calories will start to count up and the computer will begin beep to remind you. (This data is a rough guide for comparison of different exercise sessions and should not be used in medical treatment).

PULSE: Displays your current heart rate figures after you grip the handlebar sensors with both your hands during exercise. To ensure the pulse readout is more precise, please always hold on to the handlebar grip sensors with two hands instead of just with one hand only when you try to test your heart rate figures.

HOW TO INSTALL THE BATTERIES

1. Remove the battery cover on the back of the computer.
2. Place two size AA batteries into the battery housing.
3. Insure batteries are correctly positioned and battery springs are in proper contact with batteries.
4. Re-install the battery cover.
5. If the display is illegible or only partial segment appears, remove batteries and wait 15 seconds before reinstalling

ADJUSTMENTS

ADJUSTING THE ADJUSTABLE LEVELER

Turn the adjustable leveler on the rear stabilizer as needed to level the recumbent bike.

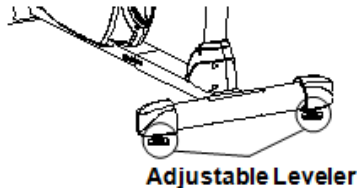

ADJUSTING THE FRONT HANDLEBAR

Hold the front handlebar while loosening the front handlebar T-Knob. Adjust the front handlebar to the desired position and turn the front handlebar T-Knob in a clockwise direction to tighten.

NOTE: Continue to turn the front handlebar T-Knob until front handlebar is secure before exercising.

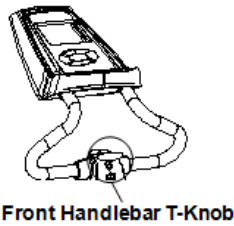

ADJUSTING THE TENSION CONTROL KNOB

To increase the tension, turn the tension control knob in a clockwise direction. To decrease the tension, turn the tension control knob in a counterclockwise direction.

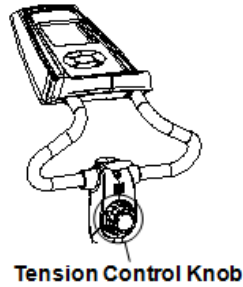

ADJUSTING THE SEAT FORWARD OR BACK

Release the triangle knob from the rear main frame. Turn the round knob in a counterclockwise direction until it can be pulled out. Pull out the round knob and then slide the back and seat support bracket back or forth direction to the suitable position. Lock the back and seat support bracket in place by releasing the round knob and sliding the back and seat support bracket back or forth slightly until the round knob "pops" down into the hole of the seat sliding tube. For added safety, tighten the round knob and triangle knob in a clockwise direction.

NOTE: When adjusting the seat back or forth direction, make sure the bushing does not exceed the mark line on the seat sliding tube.

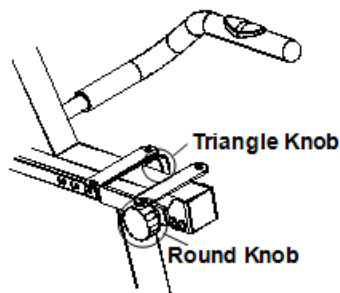

MAINTENANCE

CLEANING

The recumbent bike can be cleaned with a soft clean damp cloth. Do not use abrasives or solvents on plastic parts. Please wipe your perspiration off the recumbent bike after each use. Be careful not to get excessive moisture on the computer display panel as this might cause an electrical hazard or electronics to fail. Please keep the recumbent bike, especially the computer console out of direct sunlight to prevent screen damage. Please inspect all assembly bolts, nuts, screws, and pedals on the machine for proper tightness every week.

STORAGE

Store the recumbent bike in a clean and dry environment away from children.

TROUBLESHOOTING

TROUBLE	SOLUTION
The recumbent bike wobbles when in use.	Turn the adjustable lever on the rear stabilizer as needed to level the recumbent bike.
There is no display on the computer console.	<ol style="list-style-type: none">1. Remove the computer console and verify the wires that come from the computer console are properly connected to the wires that come from the front handlebar post.2. Check if the batteries are correctly positioned and battery springs are in proper contact with batteries.3. The batteries in the computer console may be dead. Replace with new batteries.
There is no heart rate reading or heart rate reading is erratic / inconsistent.	<ol style="list-style-type: none">1. Make sure that the wire connections for the hand pulse sensors are secure.2. To ensure the pulse readout is more precise, please always hold on to the handlebar grip sensors with both hands instead of just with one hand when you try to test your heart rate figures.3. Avoid gripping the hand pulse sensors too tight. Try to maintain moderate pressure while holding onto the hand pulse sensors.
The recumbent bike makes a squeaking noise when in use.	The bolts may be loose on the recumbent bike. Please inspect all of the bolts and tighten any loose bolts.

WARM UP AND COOL DOWN ROUTINE

The **WARM-UP** is an important part of any workout. The purpose of warming up is to prepare your body for exercise and to minimize injuries. Warm up for two to five minutes before aerobic exercising. It should begin every session to prepare your body for more strenuous exercise by heating up and stretching your muscles, increasing your circulation and pulse rate, and delivering more oxygen to your muscles.

COOL DOWN at the end of your workout, repeat these exercises to reduce soreness in tired muscles. The purpose of cooling down is to return the body to its resting state at the end of each exercise session. A proper cool-down slowly lowers your heart rate and allows blood to return to the heart.

HEAD ROLLS

Rotate your head to the right for one count, you should feel a stretching sensation up the left side of your neck. Then rotate your head back for one count, stretching your chin to the ceiling and letting

your mouth open. Rotate your head to the left for one count, then drop your head to your chest for one count.



SHOULDER LIFTS

Lift your right shoulder toward your ear for one count. Then lift your left shoulder up for one count as you lower your right shoulder.



SIDE STRETCHES

Open your arms to the side and lift them until they are over your head. Reach your right arm as far toward the ceiling as you can for one count. Repeat this action with your left arm.



QUADRICEPS STRETCH

With one hand against a wall for balance, reach behind you and pull your right foot up. Bring your heel as close to your buttocks as possible. Hold for 15 counts and repeat with left foot.



INNER THIGH STRETCH

Sit with the soles of your feet together and your knees pointing outward. Pull your feet as close to your groin as possible. Gently push your knees toward the floor. Hold for 15 counts.



TOE TOUCHES

Slowly bend forward from your waist, letting your back and shoulders relax as you stretch toward your toes. Reach as far as you can and hold for 15 counts.



HAMSTRING STRETCHES

Extend your right leg. Rest the sole of your left foot against your right inner thigh. Stretch toward your toe as far as possible. Hold for 15 counts. Relax and then repeat with left leg.



CALF/ACHILLES STRETCH

Lean against a wall with your left leg in front of the right and your arms forward. Keep your right leg straight and the left foot on the floor; then bend the left leg and lean forward by moving your hips toward the wall. Hold, then repeat on the other side for 15 counts.



TERMS AND CONDITIONS OF WARRANTY, WARRANTY CLAIMS

General Conditions of Warranty and Definition of Terms

All Warranty Conditions stated hereunder determine Warranty Coverage and Warranty Claim Procedure. Conditions of Warranty and Warranty Claims are governed by Act No. 40/1964 Coll. Civil

Code, Act No. 513/1991 Coll., Commercial Code, and Act No. 634/1992 Coll., Consumer Protection Act, as amended, also in cases that are not specified by these Warranty rules.

The seller is SEVEN SPORT s.r.o. with its registered office in Borivojova Street 35/878, Prague 13000, Company Registration Number: 26847264, registered in the Trade Register at Regional Court in Prague, Section C, Insert No. 116888.

According to valid legal regulations it depends whether the Buyer is the End Customer or not.

“The Buyer who is the End Customer” or simply the “End Customer” is the legal entity that does not conclude and execute the Contract in order to run or promote his own trade or business activities.

“The Buyer who is not the End Customer” is a Businessman that buys Goods or uses services for the purpose of using the Goods or services for his own business activities. The Buyer conforms to the General Purchase Agreement and business conditions to the extent specified in the Commercial Code.

These Conditions of Warranty and Warranty Claims are an integral part of every Purchase Agreement made between the Seller and the Buyer. All Warranty Conditions are valid and binding, unless otherwise specified in the Purchase Agreement, in the Amendment to this Contract or in another written agreement.

Warranty Conditions

Warranty Period

The Seller provides the Buyer a 24 months Warranty for Goods Quality, unless otherwise specified in the Certificate of Warranty, Invoice, Bill of Delivery or other documents related to the Goods. The legal warranty period provided to the Consumer is not affected.

By the Warranty for Goods Quality, the Seller guarantees that the delivered Goods shall be, for a certain period of time, suitable for regular or contracted use, and that the Goods shall maintain its regular or contracted features.

The Warranty does not cover defects resulting from:

User's fault, i.e. product damage caused by unqualified repair work, improper assembly, insufficient insertion of seat post into frame, insufficient tightening of pedals and cranks

Improper maintenance

Mechanical damages

Regular use (e.g. wearing out of rubber and plastic parts, joints etc.)

Unavoidable event, natural disaster

Adjustments made by unqualified person

Improper maintenance, improper placement, damages caused by low or high temperature, water, inappropriate pressure, shocks, intentional changes in design or construction etc.

Warranty Claim Procedure

The Buyer is obliged to check the Goods delivered by the Seller immediately after taking the responsibility for the Goods and its damages, i.e. immediately after its delivery. The Buyer must check the Goods so that he discovers all the defects that can be discovered by such check.

When making a Warranty Claim the Buyer is obliged, on request of the Seller, to prove the purchase and validity of the claim by the Invoice or Bill of Delivery that includes the product's serial number, or eventually by the documents without the serial number. If the Buyer does not prove the validity of the Warranty Claim by these documents, the Seller has the right to reject the Warranty Claim.

If the Buyer gives notice of a defect that is not covered by the Warranty (e.g. in the case that the Warranty Conditions were not fulfilled or in the case of reporting the defect by mistake etc.), the Seller is eligible to require a compensation for all the costs arising from the repair. The cost shall be calculated according to the valid price list of services and transport costs.

If the Seller finds out (by testing) that the product is not damaged, the Warranty Claim is not accepted. The Seller reserves the right to claim a compensation for costs arising from the false Warranty Claim.

In case the Buyer makes a claim about the Goods that is legally covered by the Warranty provided by the Seller, the Seller shall fix the reported defects by means of repair or by the exchange of the damaged part or product for a new one. Based on the agreement of the Buyer, the Seller has the right to exchange the defected Goods for a fully compatible Goods of the same or better technical characteristics. The Seller is entitled to choose the form of the Warranty Claim Procedures described in this paragraph.

The Seller shall settle the Warranty Claim within 30 days after the delivery of the defective Goods, unless a longer period has been agreed upon. The day when the repaired or exchanged Goods is handed over to the Buyer is considered to be the day of the Warranty Claim settlement. When the Seller is not able to settle the Warranty Claim within the agreed period due to the specific nature of the Goods defect, he and the Buyer shall make an agreement about an alternative solution. In case such agreement is not made, the Seller is obliged to provide the Buyer with a financial compensation in the form of a refund.



SEVEN SPORT s.r.o.

Sídlo: Bořivojova 35/878, 130 00, Praha 3, ČR
Centrála: Dělnická 957, 749 01 Vítkov
Reklamace a servis: Čermenská 486, 749 01 Vítkov

IČO: 26847264
DIČ: CZ26847264
Telefon: +420 556 300 970
Mail: eshop@insportline.cz
reklamace@insportline.cz
servis@insportline.cz
Web: www.insportline.cz

SK

inSPORTline s.r.o.

Centrála, reklamácie, servis: Električná 6471, 911 01 Trenčín, SK

IČO: 36311723
DIČ: SK2020177082
Telefón: +421(0)326 526 701
Mail: objednavky@insportline.sk
reklamacie@insportline.sk
servis@insportline.sk
Web: www.insportline.sk

Date of Sale:

Stamp and Signature of Seller: