

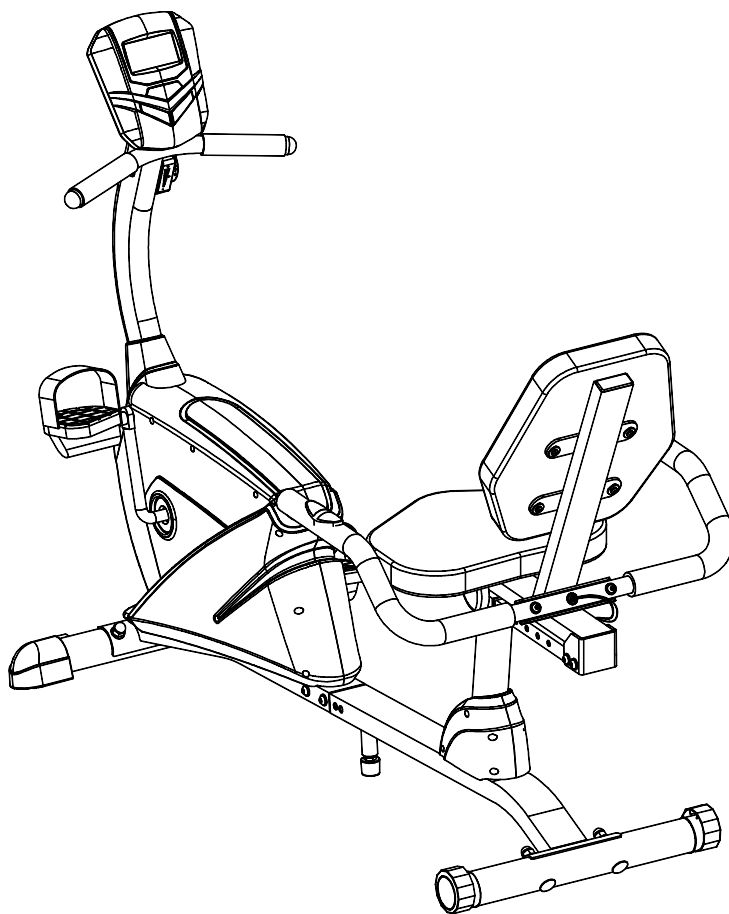

USER MANUAL - EN
IN 8244 Recumbent inSPORTline Varis



IMPORTANT: Read all instructions carefully before using this product. Retain this owner's manual for future reference.

The specifications of this product may vary from this photo, subject to change without notice.

CONTENTS

- IMPORTANT SAFETY INSTRUCTIONS 3
- OVERVIEW DRAWING..... 4
- PARTS LIST 5
 - HARDWARE PACKING LIST 7
 - TOOLS..... 7
- ASSEMBLY INSTRUCTIONS 8
 - STEP 1: REAR MAIN FRAME INSTALLATION 8
 - STEP 2: FRONT AND REAR STABILIZERS INSTALLATION..... 9
 - STEP 3: FRONT HANDLEBAR POST AND FOOT PEDALS INSTALLATION 10
 - STEP 4: SEAT SLIDING TUBE, BACK / SEAT SUPPORT BRACKET, AND HANDLEBAR INSTALLATION 11
 - STEP 5: COMPUTER AND SEAT/BACK CUSHIONS INSTALLATION 12
- OPERATING THE COMPUTER..... 13
- ADJUSTMENTS 14
 - ADJUSTING THE TENSION CONTROL KNOB 14
 - ADJUSTING THE REAR STABILIZER END CAP..... 15
 - ADJUSTING THE SEAT FORWARD OR BACK..... 15
- MAINTENANCE 15
 - CLEANING..... 15
 - STORAGE..... 16
- TROUBLESHOOTING 16
- WARM UP AND COOL DOWN ROUTINE..... 16
- TERMS AND CONDITIONS OF WARRANTY, WARRANTY CLAIMS..... 18

IMPORTANT SAFETY INSTRUCTIONS

Basic precautions should always be followed, including the following important safety instructions when using this equipment. Read all instructions before using this equipment.

1. Read all instructions and follow it carefully before using this equipment. Make sure the equipment is properly assembled and tightened before use.
2. Before exercise, in order to avoid injuring the muscle, warm-up exercises are recommended.
3. Please make sure all parts are not damaged and fixed well before use. This equipment should be placed on a flat surface when using. Using a mat or other covering material on the ground is recommended.
4. Please wear proper clothes and shoes when using this equipment; do not wear clothes that may catch any part of the equipment; remember to tighten the pedaling straps.
5. Do not attempt any maintenance or adjustments other than those described in this manual. Should any problems arise, discontinue use and consult your local dealer.
6. Do not use the equipment outdoors.
7. This equipment is for household use only. It is not a commercial model. Class: HC according to EN 957)
8. Only one person at a time should use this equipment.
9. If you feel any chest pains, nausea, dizziness, or short of breath, you should stop exercising immediately and consult your physician before continuing.
10. Care should be taken in mounting or dismounting the equipment.
11. Do not allow children to use or play on the equipment. Keep children and pets away from the equipment while in use. This machine is designed for adults use only. The minimum free space required for safe operation is not less than two meters.
12. The maximum weight capacity for this product is 130 kgs.
- 13.

WARNING: Before beginning any exercise program consult your physician. This is especially important for the people who are over 35 years old or who have pre-existing health problems. Read all instructions before using any fitness equipment.

CAUTION: Read all instructions carefully before operating this product. Retain this Owner's Manual for future reference.

OVERVIEW DRAWING

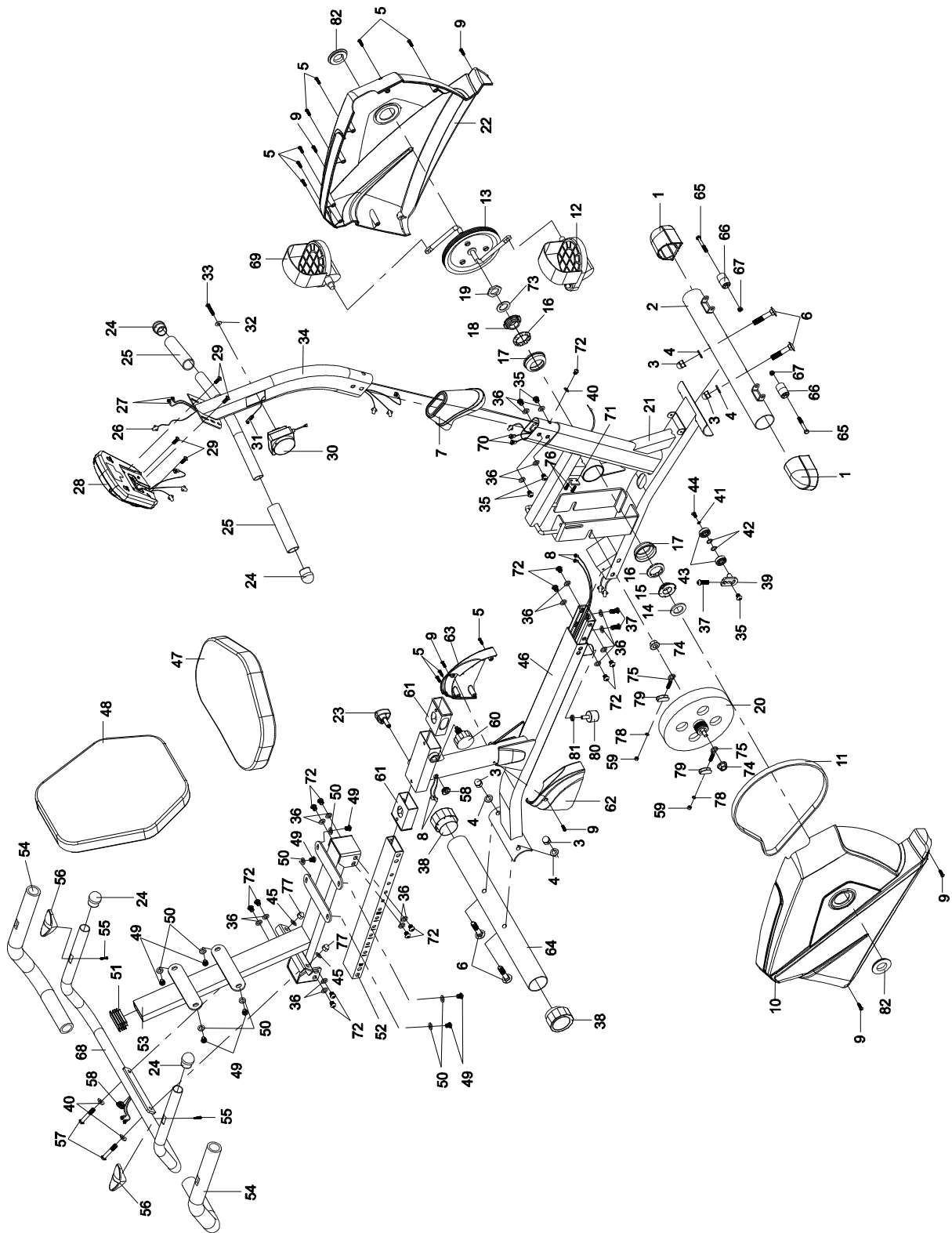







PARTS LIST

No.	Description	Qty
001	Front Stabilizer End Cap	2
002	Front Stabilizer	1
003	Cap Nut M10	4
004	Curve Washer Ø10	4
005	Screw ST4.2x25	10
006	Bolt M10x57	4
007	Front Handlebar Post Cover	1
008	Middle Section Hand Pulse Sensor Wire L=1000mm	1
009	Pan Head Phillips Self Drilling Screw ST4.2x25	6
010	Right Cover	1
011	Belt 330J6	1
012	Right Foot Pedal YH-30X	1
013	Crank	1
014	Washer Ø34.5xØ23x2.5	1
015	Bearing Nut II 7/8"	1
016	Bearing	2
017	Bearing Cup	2
018	Bearing Nut I 15/16"	1
019	Hexagon Nut 7/8"	1
020	Flywheel Ø230	1
021	Front Main Frame	1
022	Left Cover	1
023	Triangle Knob M12x55	1
024	Round End Cap for Handlebar Ø25x1.5	4
025	Front Handlebar Foam Grip Ø30xØ24x160	2
026	Extension Sensor Wire L=500mm	1
027	Extension Hand Pulse Sensor Wire I L=500mm	2
028	Computer (HR-1586)	1
029	Bolt M5x10	4
030	Tension Control Knob	1
031	Tension Cable L=750mm	1
032	Big Washer Ø5xØ20x1	1
033	Bolt M5x20	1
034	Front Handlebar Post	1
035	Bolt M8x10	5

036	Washer Ø8xØ16x1.5	18
037	Bolt M8x30	3
038	Rear Stabilizer End Cap	2
039	Idle Wheel Bracket	1
040	Curve Washer Ø8xØ20x2	3
041	Washer Ø6xØ12x1	1
042	Washer Ø10.2xØ14x1	2
043	Bearing 6000ZZ	2
044	Bolt M6x10	1
045	Big Washer Ø8xØ20x2	2
046	Rear Main Frame	1
047	Seat Cushion 250x345x40	1
048	Back Cushion 310x345x40	1
049	Bolt M6x15	8
050	Big Washer Ø6xØ18x1.5	8
051	Back and Seat Support Bracket End Cap 23x53x2	1
052	Seat Sliding Tube	1
053	Back and Seat Support Bracket	1
054	Handlebar Foam Grip Ø30xØ24x510	2
055	Screw ST4.2x20	2
056	Hand Pulse Sensor with Wire L=750	2
057	Bolt M8x45	2
058	Wire Plug Ø12.1	2
059	Nut M6	2
060	Round Knob M16x1.5	1
061	Bushing	2
062	Right Rear Main Frame Cover	1
063	Left Rear Main Frame Cover	1
064	Rear Stabilizer Ø50x1.5x430	1
065	Bolt M6x48	2
066	Transport Wheel Ø23xØ6x32	2
067	Nylon Nut M6	2
068	Handlebar	1
069	Left Foot Pedal YH-30X	1
070	Extension Hand Pulse Sensor Wire II L=1000mm	2
071	Sensor with Wire L=450mm	1
072	Bolt M8x15	13
073	Washer Ø40xØ24x3	1

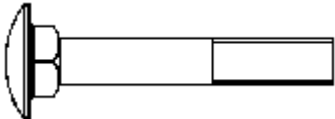
074	Nut M10x1	2
075	Eyebolt M6x36	2
076	Screw ST2.9x12	2
077	Cap Nut M8	2
078	Spring Washer Ø6xØ11.2x2	2
079	Tension Bracket	2
080	Rubber Bolt	1
081	Nut M8	1
082	Cover Cap Ø40xØ25x10	2

HARDWARE PACKING LIST

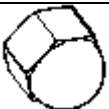
 <p>(3) Cap Nut M10 4PCS</p>	 <p>(4) Curve Washer Ø10 4PCS</p>	 <p>(6) Bolt M10x57 4PCS</p>
 <p>(40) Curve Washer Ø8xØ20x2 2PCS</p>	 <p>(45) Big Washer Ø8xØ20x2 2PCS</p>	 <p>(57) Bolt M8x45 2PCS</p>
 <p>(77) Cap Nut M8 2PCS</p>		

TOOLS

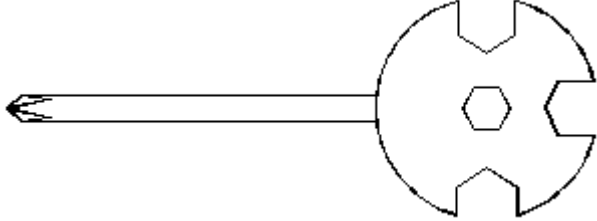
 <p>Allen Wrench S6 1 PC</p>	 <p>Multi Hex Tool with Phillips Screwdriver S10, S13, S14, S15 1 PC</p>
---	--

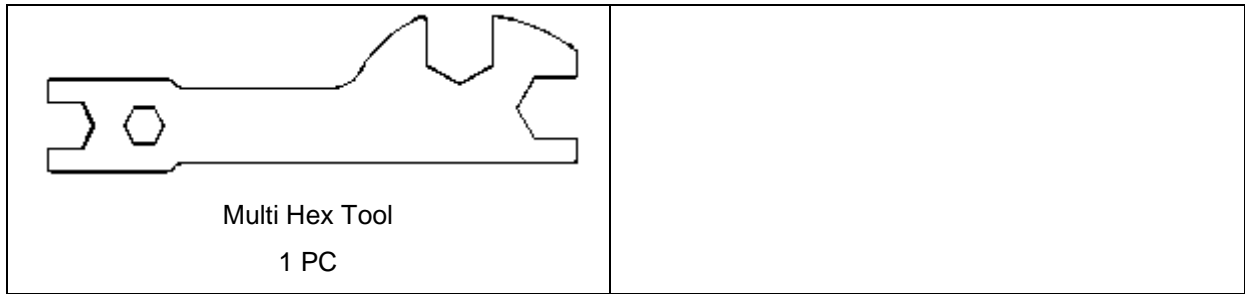

ASSEMBLY INSTRUCTIONS

STEP 1: REAR MAIN FRAME INSTALLATION

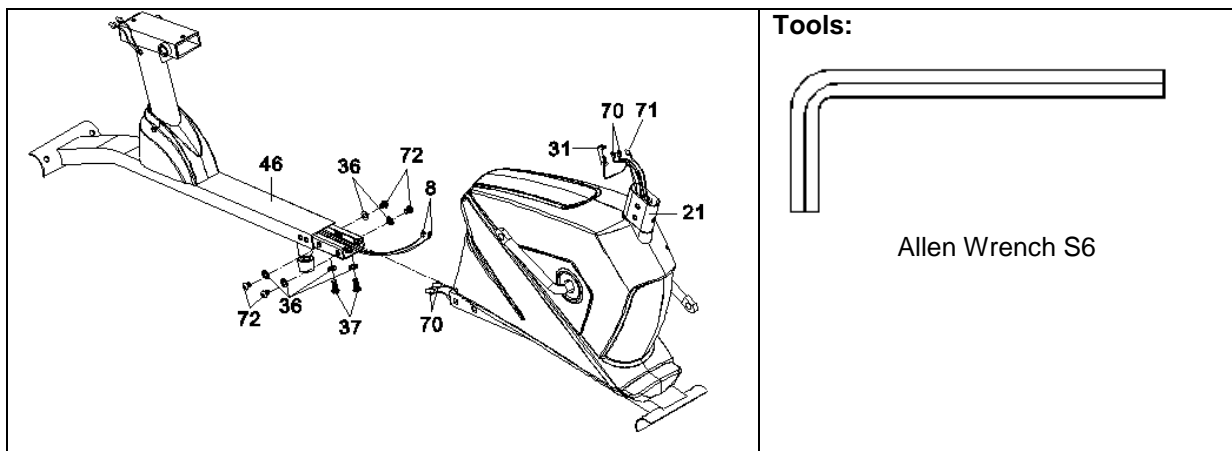

Remove two M8x30 Bolts (37), four M8x15 Bolts (72), and six Ø8xØ16x1.5 Washers (36) from the Rear Main Frame (46). Remove bolts with the S6 Allen Wrench provided.



Connect the Middle Section Hand Pulse Sensor Wires (8) from the Rear Main Frame (46) to the Extension Hand Pulse Sensor Wires II (70) from the Front Main Frame (21).

Attach the Rear Main Frame (46) into the Front Main Frame (21) with two M8x30 Bolts (37), four M8x15 Bolts (72), and six Ø8xØ16x1.5 Washers (36) that were removed. Tighten bolts with the S6 Allen Wrench provided.

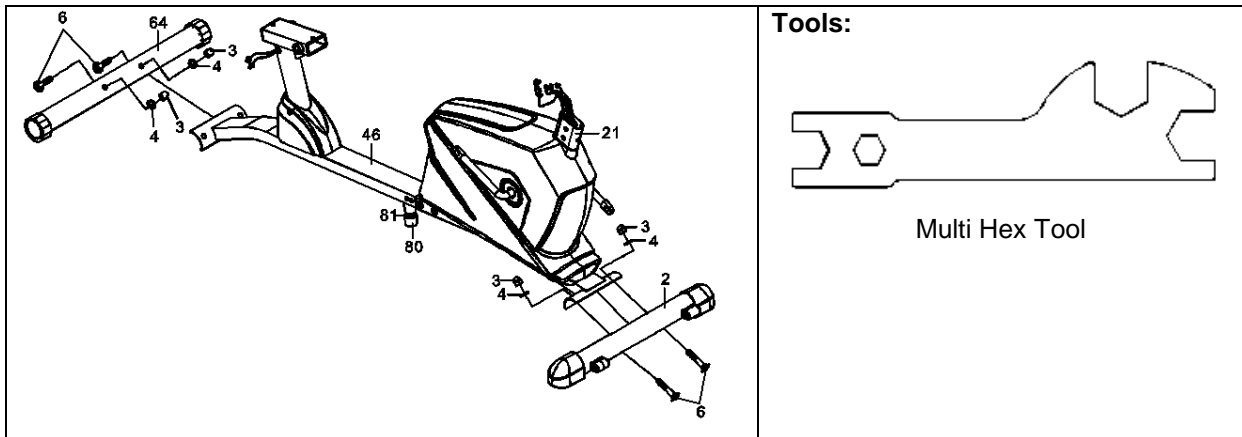
STEP 2: FRONT AND REAR STABILIZERS INSTALLATION

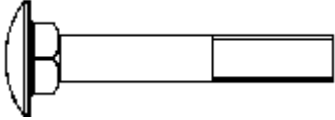

Hardware:

 <p>(3) Cap Nut M10 4PCS</p>	 <p>(4) Curve Washer Ø10 4PCS</p>	 <p>(6) Bolt M10x57 4PCS</p>
---	--	---

Position the Front Stabilizer (2) in front of the Front Main Frame (21) and align bolt holes.

Attach the Front Stabilizer (2) onto the front curve of the Front Main Frame (21) with two M10 Cap Nuts (3), two Ø10 Curve Washers (4), and two M10x75 Bolts (6). Tighten cap nuts with the Multi Hex Tool provided.

Position the Rear Stabilizer (64) behind the Rear Main Frame (46) and align bolt holes.

Attach the Rear Stabilizer (64) onto the rear curve of the Rear Main Frame (46) with two M10 Cap Nuts (3), two Ø10 Curve Washers (4), and two M10x75 Bolts (6). Tighten cap nuts with the Multi Hex Tool provided.

You may turn the Rubber Bolt (80) and M8 Nut (81) on the Rear Main Frame (46) as needed to level the recumbent bike.

STEP 3: FRONT HANDLEBAR POST AND FOOT PEDALS INSTALLATION

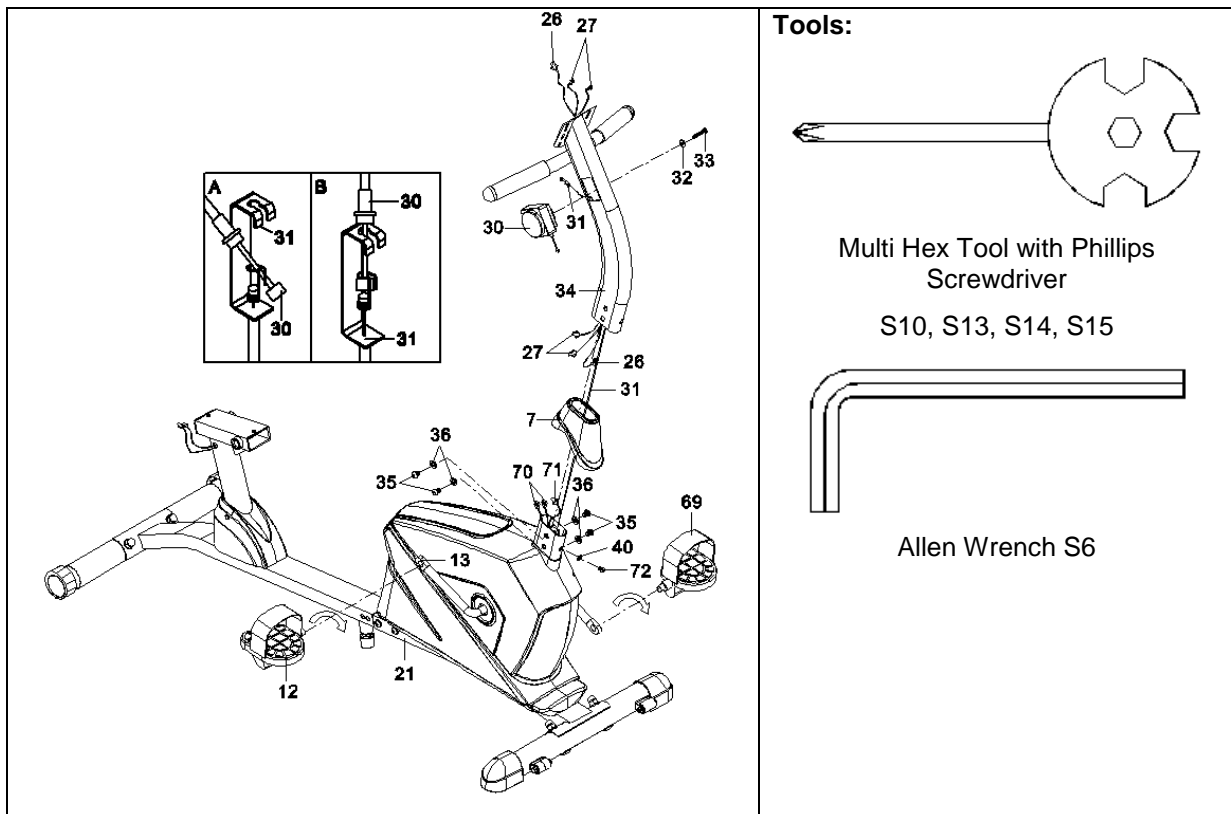

Tools:

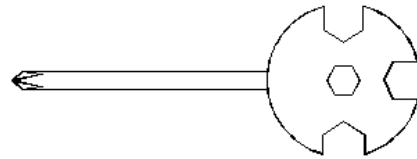

Multi Hex Tool with Phillips
Screwdriver

S10, S13, S14, S15



Allen Wrench S6

Remove one $\text{\O}8 \times \text{\O}20 \times 2$ Curve Washer (40), one M8x15 Bolt (72), four M8x10 Bolts (35) and four $\text{\O}8 \times \text{\O}16 \times 1.5$ Washers (36) from the Front Main Frame (21). Remove bolts with the S6 Allen Wrench provided.

Slide the Front Handlebar Post Cover (7) up to the Front Handlebar Post (34).

Insert the Tension Cable (31) through into the bottom hole of Front Handlebar Post (34) and pull it out from the square hole of Front Handlebar Post (34).

Connect the Sensor Wire (71) and Extension Hand Pulse Sensor Wires II (70) from the Front Main Frame (21) to the Extension Sensor Wire (26) and Extension Hand Pulse Sensor Wires I (27) from the Front Handlebar Post (34).

Insert the Front Handlebar Post (34) onto the tube of the Front Main Frame (21) and secure with one $\text{\O}8 \times \text{\O}20 \times 2$ Curve Washer (40), one M8x15 Bolt (72), four M8x10 Bolts (35) and four $\text{\O}8 \times \text{\O}16 \times 1.5$ Washers (36) that were removed. Tighten bolts with the S6 Allen Wrench provided. Slide the Front Handlebar Post Cover (7) down to the Front Main Frame (21).

Remove the $\text{\O}5 \times \text{\O}20 \times 1$ Big Washer (32) and M5x20 Bolt (33) from the Tension Control Knob (30). Remove bolt with the Multi Hex Tool with Phillips Screwdriver provided.

Put the cable end of resistance cable of Tension Control Knob (30) into the spring hook of Tension Cable (31) as shown in drawing A of figure 3. Pull the resistance cable of Tension Control Knob (30) up and force it into the gap of metal bracket of Tension Cable (31) as shown in drawing B of figure 3. Attach the Tension Control Knob (30) onto the Front Handlebar Post (34) with the $\text{\O}5 \times \text{\O}20 \times 1$ Big Washer (32) and M5x20 Bolt (33) that were removed. Tighten bolt with the Multi Hex Tool with Phillips Screwdriver provided.

FOOT PEDALS INSTALLATION:

The Cranks, Foot Pedals, Pedal Shafts and Pedal Straps are marked "R" for Right and "L" for Left.

Insert the pedal shaft of Left Foot Pedal (69) into threaded hole in the left Crank (13). Turn the pedal shaft by hand in the counter-clockwise direction until snug.

Note: DO NOT turn the pedal shaft in the clockwise direction, doing so will strip the threads.

Tighten the pedal shaft of Left Foot Pedal (69) with the Multi Hex Tool with Phillips Screwdriver provided.

Insert pedal shaft of Right Foot Pedal (12) into threaded hole in right Crank (13). Turn the pedal shaft by hand in the clockwise direction until snug. Tighten pedal shaft of Right Foot Pedal (12) with the Multi Hex Tool with Phillips Screwdriver provided.

STEP 4: SEAT SLIDING TUBE, BACK / SEAT SUPPORT BRACKET, AND HANDLEBAR INSTALLATION

Tools:

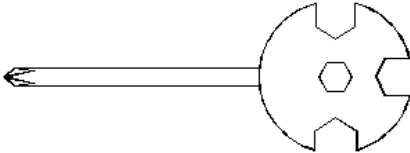





Multi Hex Tool with Phillips Screwdriver
S10, S13, S14, S15



Allen Wrench S6

Hardware:

 (40) Curve Washer Ø8xØ20x2 2 PCS	 (45) Big Washer Ø8xØ20x2 2 PCS	 (57) Bolt M8x45 2 PCS	 (77) Cap Nut M8 2 PCS
---	---	--	---

Remove eight Ø8xØ16x1.5 Washers (36) and eight M8x15 Bolts (72) from the Seat Sliding Tube (52). Remove bolts with the S6 Allen Wrench provided.

Insert the Seat Sliding Tube (52) into the Bushings (61) of the Rear Main Frame (46).

Attach the Seat Sliding Tube (52) to the Back and Seat Support Bracket (53) with eight Ø8xØ16x1.5 Washers (36) and eight M8x15 Bolts (72) that were removed. Tighten bolts with the S6 Allen Wrench provided.

Adjust the seat position and insert the Round Knob (60) and Triangle Knob (23). Turn the Round Knob (60) and Triangle Knob (23) in the clockwise direction to tighten.

Attach the Handlebar (68) onto the Back and Seat Support Bracket (53) with two M8x45 Bolts (57), two Ø8xØ20x2 Curve Washers (40), two Ø8xØ20x2 Big Washers (45), and two M8 Cap Nuts (77). Tighten nuts with the Multi Hex Tool with Phillips Screwdriver provided.

Connect the Middle Section Hand Pulse Sensor Wires (8) from the Rear Main Frame (46) to the Hand Pulse Sensor Wires (56) from the Handlebar (68).

STEP 5: COMPUTER AND SEAT/BACK CUSHIONS INSTALLATION

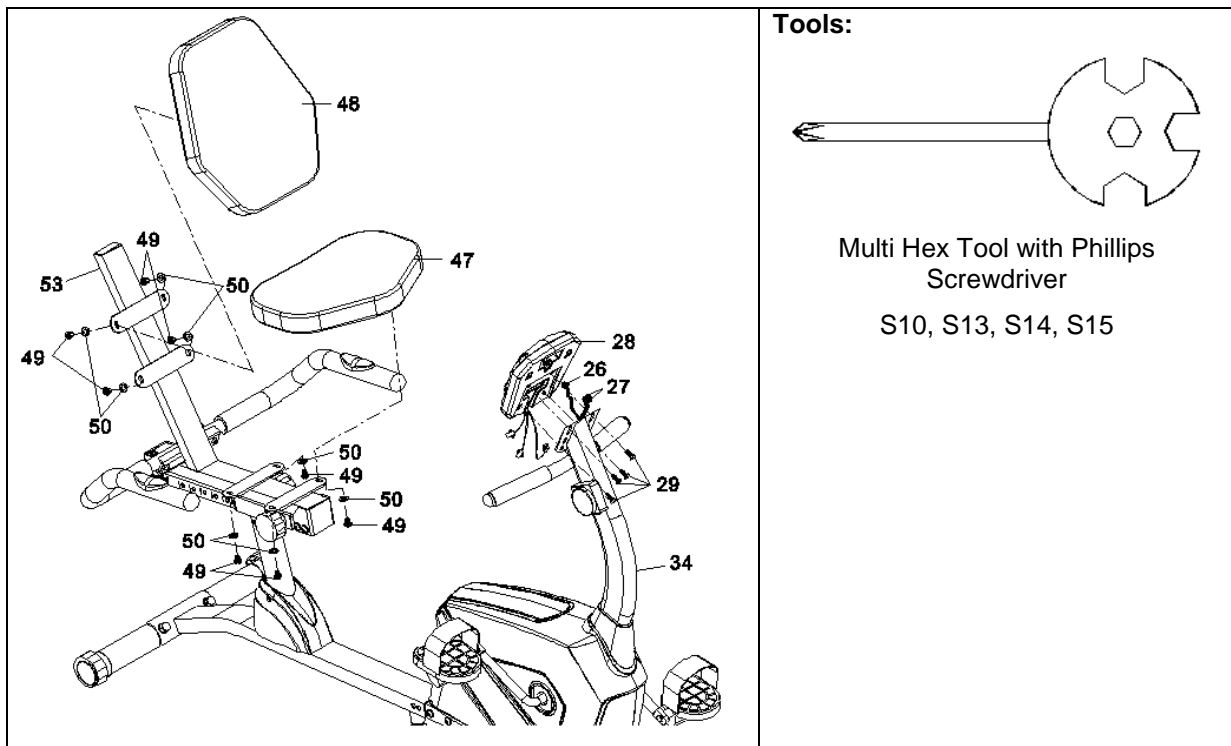

Remove four M5x10 Bolts (29) from the Computer (28). Remove bolts with the Multi Hex Tool with Phillips Screwdriver provided.

Connect the Extension Sensor Wire (26) and Extension Hand Pulse Sensor Wires I (27) from the Front Handlebar Post (34) to the wires that come from the Computer (28). Tuck wires into the Front Handlebar Post (34).

Attach the Computer (28) onto the top end of the Front Handlebar Post (34) with four M5x10 Bolts (29) that were removed. Tighten bolts with the Multi Hex Tool with Phillips Screwdriver provided.

Remove eight M6x15 Bolts (49) and eight Ø6xØ18x1.5 Big Washers (50) from the back of the Seat and Back Cushions (47, 48). Remove bolts with the Multi Hex Tool with Phillips Screwdriver provided. Then attach the Seat and Back Cushions (47, 48) onto the Back and Seat Support Bracket (53) with eight M6x15 Bolts (49) and eight Ø6xØ18x1.5 Big Washers (50) that were removed. Tighten bolts with the Multi Hex Tool with Phillips Screwdriver provided.

OPERATING THE COMPUTER



SPECIFICATION

FUNCTION	RANGE
TIME	0:00-99:59 min:sec
SPEED	0.0-99.9 km/h
DIST (DISTANCE)	0.0-999.9 km
CAL (CALORIES)	0.0-999.9 kcal
ODO (ODOMETER)	0.0-9999 km
♥ (PULSE)	40-239 beats/min

USING YOUR COMPUTER

The computer can be activated by pressing the buttons or by pedaling. If you leave the equipment idle for approximate 4 minutes, the power will turn off automatically.

BUTTON FUNCTIONS

MODE: Press the MODE button to select each function of computer.

Press and hold the MODE button for 3 seconds, all data values will clear to zero except the ODO (ODOMETER) data values.

SET: Press the SET button to set data values of TIME, DISTANCE, CALORIES, or PULSE for target pre-setting.

RESET: Press the RESET button to clear data values of TIME, DISTANCE, or CALORIES to zero. Press the RESET button to clear data values of TIME, DISTANCE, CALORIES, or PULSE to zero for target pre-setting.

COMPUTER FUNCTIONS

SCAN: Press the MODE button until the screen displays SCAN; the computer will automatically scan the function of TIME, SPEED, DIST (DISTANCE), CAL (CALORIES), ODO (ODOMETER), and ♥ (PULSE) every 5 seconds.

TIME: Displays your elapsed workout time in minutes and seconds. You may also pre-set target time in STOP mode before training. To set TIME press the MODE button until you see the TIME displays on the screen. Press the SET button to change the time, each time you press the SET button TIME should change by 1 minute. Press the RESET button to clear the target time to zero. The pre-set target time range is from 0:00 to 99:00 minutes. Once you pre-set target time and then start to exercise, time starts counting down from pre-set target time to 0:00 per 1 second backward. When the pre-set target time counts down to 0:00, time will start to count up and the computer will begin beeping to remind you.

SPEED: Display the current training speed.

DIST (DISTANCE): Displays the accumulative distance traveled during workout. You may also pre-set target distance in STOP mode before training. To set DISTANCE press the MODE button until you see the DIST displays on the screen. Press the SET button to change the distance. Press the RESET button to clear the target distance to zero. The pre-set target distance range is from 0.0 to 999.0 km. Once you pre-set target distance and then start to exercise, distance starts counting down from pre-set target distance to 0.0. When the pre-set target distance counts down to 0.0, distance will start to count up and the computer will begin beeping to remind you.

CAL (CALORIES): Displays the total accumulated calories burned during workout. You may also pre-set target calories in STOP mode before training. To set CALORIES press the MODE button until you see the CAL displays on the screen. Press the SET button to change the calories. Press the RESET button to clear the target calories to zero. The pre-set target calories range is from 0.0 to 999.0 calories. Once you pre-set target calories and then start to exercise, calories start counting down from pre-set target calories to 0.0. When the pre-set target calories count down to 0.0, calories will start to count up and the computer will begin beeping to remind you. (This data is a rough guide for comparison of different exercise sessions and should not be used in medical treatment).

ODO (ODOMETER): Displays the total accumulative distance traveled. The data values of ODO can not be clear to zero by pressing and holding the MODE or RESET button for 3 seconds. If you take out the batteries from the computer, the ODO data values will clear to zero.

♥ **(PULSE):** Displays your current heart rate figures after you grip the handlebar sensors with both your hands during exercise. To ensure the pulse readout is more precise, please always hold on to the handlebar grip sensors with two hands instead of just with one hand only when you try to test your heart rate figures. You may also pre-set target heart rate in STOP mode before training. To set PULSE press the MODE button until you see the ♥ displays on the screen. Press the SET button to pre-set target heart rate. Press the RESET button to clear the target heart rate to zero. Once you pre-set target heart rate and then start to exercise, please grip the handlebar sensors with both your hands during exercise. If the heart rate detected greater than the target heart rate, the computer will begin beeping to remind you.

HOW TO INSTALL THE BATTERIES

1. Remove the battery cover on the back of the computer.
2. Place two size AA batteries into the battery housing.
3. Insure batteries are correctly positioned and battery springs are in proper contact with batteries.
4. Re-install the battery cover.
5. If the display is illegible or only partial segment appears, remove batteries and wait 15 seconds before reinstalling.

ADJUSTMENTS

ADJUSTING THE TENSION CONTROL KNOB

To increase the tension, turn the tension control knob in a clockwise direction. To decrease the tension, turn the tension control knob in a counterclockwise direction.

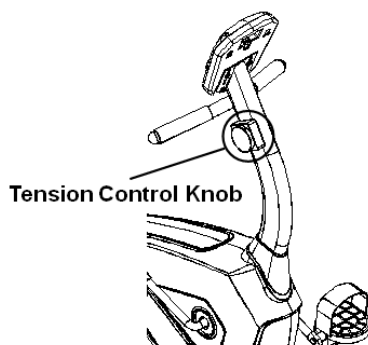

ADJUSTING THE REAR STABILIZER END CAP

Turn the rear stabilizer end cap on the rear stabilizer as needed to level the recumbent bike.

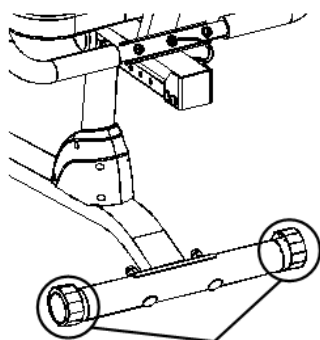

Rear Stabilizer End Cap

ADJUSTING THE SEAT FORWARD OR BACK

Release the triangle knob from the rear main frame. Turn the round knob in a counterclockwise direction until it can be pulled out. Pull out the round knob and then slide the back and seat support bracket back or forth direction to the suitable position. Lock the back and seat support bracket in place by releasing the round knob and sliding the back and seat support bracket back or forth slightly until the round knob "pops" down into the hole of the seat sliding tube. For added safety, tighten the round knob and triangle knob in a clockwise direction.

NOTE: When adjusting the seat back or forth direction, make sure the bushing does not exceed the mark line on the seat sliding tube.

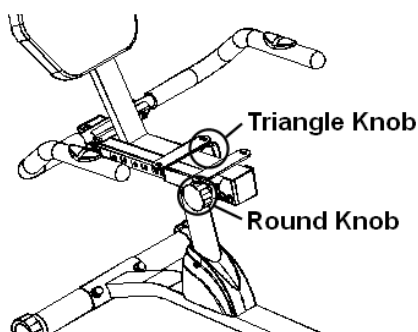

MAINTENANCE

CLEANING

The recumbent bike can be cleaned with a soft clean damp cloth. Do not use abrasives or solvents on plastic parts. Please wipe your perspiration off the recumbent bike after each use. Be careful not to

get excessive moisture on the computer display panel as this might cause an electrical hazard or electronics to fail. Please keep the recumbent bike, especially the computer console out of direct sunlight to prevent screen damage. Please inspect all assembly bolts, nuts, screws, and pedals on the machine for proper tightness every week.

STORAGE

Store the recumbent bike in a clean and dry environment away from children.

TROUBLESHOOTING

TROUBLE	SOLUTION
The recumbent bike wobbles when in use.	Turn the rear stabilizer end cap on the rear stabilizer as needed to level the recumbent bike.
There is no display on the computer console.	<ol style="list-style-type: none"> 1. Remove the computer console and verify the wires that come from the computer console are properly connected to the wires that come from the front handlebar post. 2. Check if the batteries are correctly positioned and battery springs are in proper contact with batteries. 3. The batteries in the computer console may be dead. Replace with new batteries.
There is no heart rate reading or heart rate reading is erratic / inconsistent.	<ol style="list-style-type: none"> 1. Make sure that the wire connections for the hand pulse sensors are secure. 2. To ensure the pulse readout is more precise, please always hold on to the handlebar grip sensors with both hands instead of just with one hand when you try to test your heart rate figures. 3. Avoid gripping the hand pulse sensors too tight. Try to maintain moderate pressure while holding onto the hand pulse sensors.
The recumbent bike makes a squeaking noise when in use.	The bolts may be loose on the recumbent bike. Please inspect all of the bolts and tighten any loose bolts.

WARM UP AND COOL DOWN ROUTINE

The **WARM-UP** is an important part of any workout. The purpose of warming up is to prepare your body for exercise and to minimize injuries. Warm up for two to five minutes before aerobic exercising. It should begin every session to prepare your body for more strenuous exercise by heating up and stretching your muscles, increasing your circulation and pulse rate, and delivering more oxygen to your muscles.

COOL DOWN at the end of your workout, repeat these exercises to reduce soreness in tired muscles. The purpose of cooling down is to return the body to its resting state at the end of each exercise session. A proper cool-down slowly lowers your heart rate and allows blood to return to the heart.

HEAD ROLLS

Rotate your head to the right for one count, you should feel a stretching sensation up the left side of your neck. Then rotate your head back for one count, stretching your chin to the ceiling and letting your mouth open. Rotate your head to the left for one count, then drop your head to your chest for one count.



SHOULDER LIFTS

Lift your right shoulder toward your ear for one count. Then lift your left shoulder up for one count as you lower your right shoulder.



SIDE STRETCHES

Open your arms to the side and lift them until they are over your head. Reach your right arm as far toward the ceiling as you can for one count. Repeat this action with your left arm.



QUADRICEPS STRETCH

With one hand against a wall for balance, reach behind you and pull your right foot up. Bring your heel as close to your buttocks as possible. Hold for 15 counts and repeat with left foot.



INNER THIGH STRETCH

Sit with the soles of your feet together and your knees pointing outward. Pull your feet as close to your groin as possible. Gently push your knees toward the floor. Hold for 15 counts.



TOE TOUCHES

Slowly bend forward from your waist, letting your back and shoulders relax as you stretch toward your toes. Reach as far as you can and hold for 15 counts.



HAMSTRING STRETCHES

Extend your right leg. Rest the sole of your left foot against your right inner thigh. Stretch toward your toe as far as possible. Hold for 15 counts. Relax and then repeat with left leg.



CALF/ACHILLES STRETCH

Lean against a wall with your left leg in front of the right and your arms forward. Keep your right leg straight and the left foot on the floor; then bend the left leg and lean forward by moving your hips toward the wall. Hold, then repeat on the other side for 15 counts.



TERMS AND CONDITIONS OF WARRANTY, WARRANTY CLAIMS

General Conditions of Warranty and Definition of Terms

All Warranty Conditions stated hereunder determine Warranty Coverage and Warranty Claim Procedure. Conditions of Warranty and Warranty Claims are governed by Act No. 40/1964 Coll. Civil Code, Act No. 513/1991 Coll., Commercial Code, and Act No. 634/1992 Coll., Consumer Protection Act, as amended, also in cases that are not specified by these Warranty rules.

The seller is SEVEN SPORT s.r.o. with its registered office in Borivojova Street 35/878, Prague 13000, Company Registration Number: 26847264, registered in the Trade Register at Regional Court in Prague, Section C, Insert No. 116888.

According to valid legal regulations it depends whether the Buyer is the End Customer or not.

“The Buyer who is the End Customer” or simply the “End Customer” is the legal entity that does not conclude and execute the Contract in order to run or promote his own trade or business activities.

“The Buyer who is not the End Customer” is a Businessman that buys Goods or uses services for the purpose of using the Goods or services for his own business activities. The Buyer conforms to the General Purchase Agreement and business conditions to the extent specified in the Commercial Code.

These Conditions of Warranty and Warranty Claims are an integral part of every Purchase Agreement made between the Seller and the Buyer. All Warranty Conditions are valid and binding, unless otherwise specified in the Purchase Agreement, in the Amendment to this Contract or in another written agreement.

Warranty Conditions

Warranty Period

The Seller provides the Buyer a 24 months Warranty for Goods Quality, unless otherwise specified in the Certificate of Warranty, Invoice, Bill of Delivery or other documents related to the Goods. The legal warranty period provided to the Consumer is not affected.

By the Warranty for Goods Quality, the Seller guarantees that the delivered Goods shall be, for a certain period of time, suitable for regular or contracted use, and that the Goods shall maintain its regular or contracted features.

The Warranty does not cover defects resulting from:

User's fault, i.e. product damage caused by unqualified repair work, improper assembly, insufficient insertion of seat post into frame, insufficient tightening of pedals and cranks

Improper maintenance

Mechanical damages

Regular use (e.g. wearing out of rubber and plastic parts, joints etc.)

Unavoidable event, natural disaster

Adjustments made by unqualified person

Improper maintenance, improper placement, damages caused by low or high temperature, water, inappropriate pressure, shocks, intentional changes in design or construction etc.

Warranty Claim Procedure

The Buyer is obliged to check the Goods delivered by the Seller immediately after taking the responsibility for the Goods and its damages, i.e. immediately after its delivery. The Buyer must check the Goods so that he discovers all the defects that can be discovered by such check.

When making a Warranty Claim the Buyer is obliged, on request of the Seller, to prove the purchase and validity of the claim by the Invoice or Bill of Delivery that includes the product's serial number, or eventually by the documents without the serial number. If the Buyer does not prove the validity of the Warranty Claim by these documents, the Seller has the right to reject the Warranty Claim.

If the Buyer gives notice of a defect that is not covered by the Warranty (e.g. in the case that the Warranty Conditions were not fulfilled or in the case of reporting the defect by mistake etc.), the Seller is eligible to require a compensation for all the costs arising from the repair. The cost shall be calculated according to the valid price list of services and transport costs.

If the Seller finds out (by testing) that the product is not damaged, the Warranty Claim is not accepted. The Seller reserves the right to claim a compensation for costs arising from the false Warranty Claim.

In case the Buyer makes a claim about the Goods that is legally covered by the Warranty provided by the Seller, the Seller shall fix the reported defects by means of repair or by the exchange of the damaged part or product for a new one. Based on the agreement of the Buyer, the Seller has the right to exchange the defected Goods for a fully compatible Goods of the same or better technical characteristics. The Seller is entitled to choose the form of the Warranty Claim Procedures described in this paragraph.

The Seller shall settle the Warranty Claim within 30 days after the delivery of the defective Goods, unless a longer period has been agreed upon. The day when the repaired or exchanged Goods is handed over to the Buyer is considered to be the day of the Warranty Claim settlement. When the Seller is not able to settle the Warranty Claim within the agreed period due to the specific nature of the Goods defect, he and the Buyer shall make an agreement about an alternative solution. In case such agreement is not made, the Seller is obliged to provide the Buyer with a financial compensation in the form of a refund.



SEVEN SPORT s.r.o.

Sídlo: Bořivojova 35/878, 130 00, Praha 3, ČR
Centrála: Dělnická 957, 749 01 Vítkov
Reklamace a servis: Čermenská 486, 749 01 Vítkov

IČO: 26847264
DIČ: CZ26847264
Telefon: +420 556 300 970
Mail: eshop@insportline.cz
reklamace@insportline.cz
servis@insportline.cz
Web: www.insportline.cz

SK

inSPORTline s.r.o.

Centrála, reklamácie, servis: Električná 6471, 911 01 Trenčín, SK

IČO: 36311723
DIČ: SK2020177082
Telefón: +421(0)326 526 701
Mail: objednavky@insportline.sk
reklamacie@insportline.sk
servis@insportline.sk
Web: www.insportline.sk

Date of Sale:

Stamp and Signature of Seller: