



USER MANUAL – EN

IN 8124 Digital Pedometer inSPORTline Strippy



CONTENTS

- INTRODUCTION..... 3
- BUTTONS..... 3
- OPERATING MODES 4
- SETTING YOUR PEDOMETER..... 4
- CALCULATING STRIDE LENGTH 5
- OPERATING INSTRUCTIONS 5
 - STEP MODE 5
 - DISTANCE MODE 5
 - CALORIES MODE 6
 - EXERCISE TIME MODE 6
 - MEMORY MODE 6
 - TOTAL DATA MODE 6
 - ALARM MODE 7
 - RESETTING THE PEDOMETER 7
- USB CONNECTION 7
- UPLOADING YOUR DATA 8
- BATTERY REPLACEMENT 8
- CARE AND MAINTENANCE & CLEARING..... 8
- TERMS AND CONDITIONS OF WARRANTY, WARRANTY CLAIMS..... 9

INTRODUCTION

This digital pedometer displays steps taken, distance traveled, calories burned, total exercise time, and 30-days memory storage, among many other useful features. Also, the most important, could download your exercise data to the PC.

Please read this manual carefully before using this pedometer. We suggest you keep this manual for future reference.

To keep your health and reduce chronic disease risk, we recommend you to take 10,000 steps a day. For an effective weight loss, the total steps should be between 12,000 and 15,000. If you want to achieve a higher fitness level, you are suggested to take at least 30,000 steps per day.

REMARK: In any mode (except for SET mode), press and hold MODE button for more than 2 seconds to turn on/off the pedometer function. When the pedometer function is on, the sign  is flashing.

BUTTONS

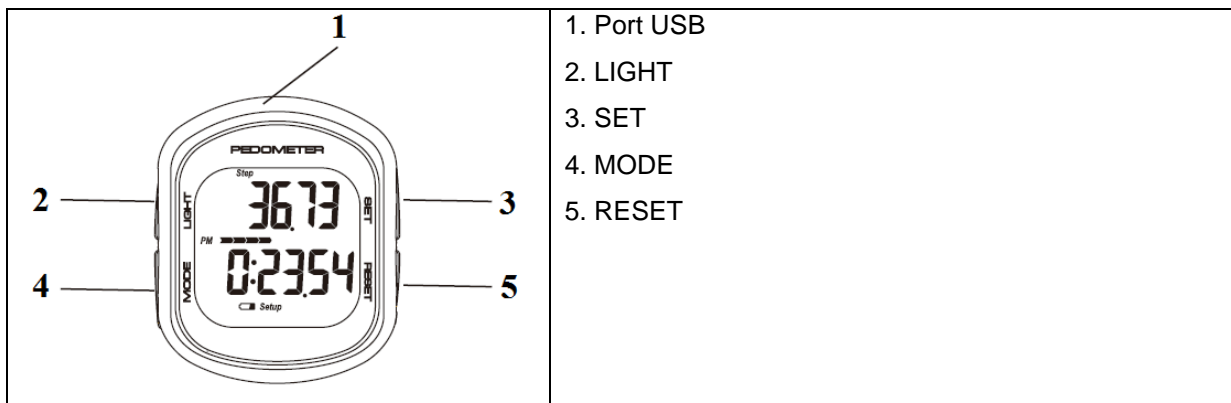

MODE BUTTON

- Scroll through modes
- Decrease value in time and user information

SET BUTTON

- Press and hold to access SETTING mode while in STEP mode & ALARM mode
- To shift between display in DISTANCE / CALORIES mode
- Scroll data in TOTAL DATA mode

RESET BUTTON

- Press and hold to clear data in STEP, DISTANCE, CALORIES, TIMER mode and TOTAL DATA mode
- Increase value in SETUP mode and Alarm setting
- Scroll through data in the past 30 days

MASTER RESET BUTTON

- Hard reset for device (will clear all data & memory)

OPERATING MODES

This pedometer has 7 operational modes. Press Mode button to scroll through modes in the following sequence:

STEP	Display the numbers of steps taken
KM/MILE	Display distance traveled
KCAL	Display calories burned
MIN	Display total exercise time
RECORD	Display the numbers of steps taken, calories burned, distance traveled, and exercise time for the past 30 days
TOTAL	Display the numbers of total steps taken, total calories burned, total distance traveled, and total exercise time for the past few days
ALM	Optional function for 2 alarm to go off at the user's expected time

SETTING YOUR PEDOMETER

SETUP MODE

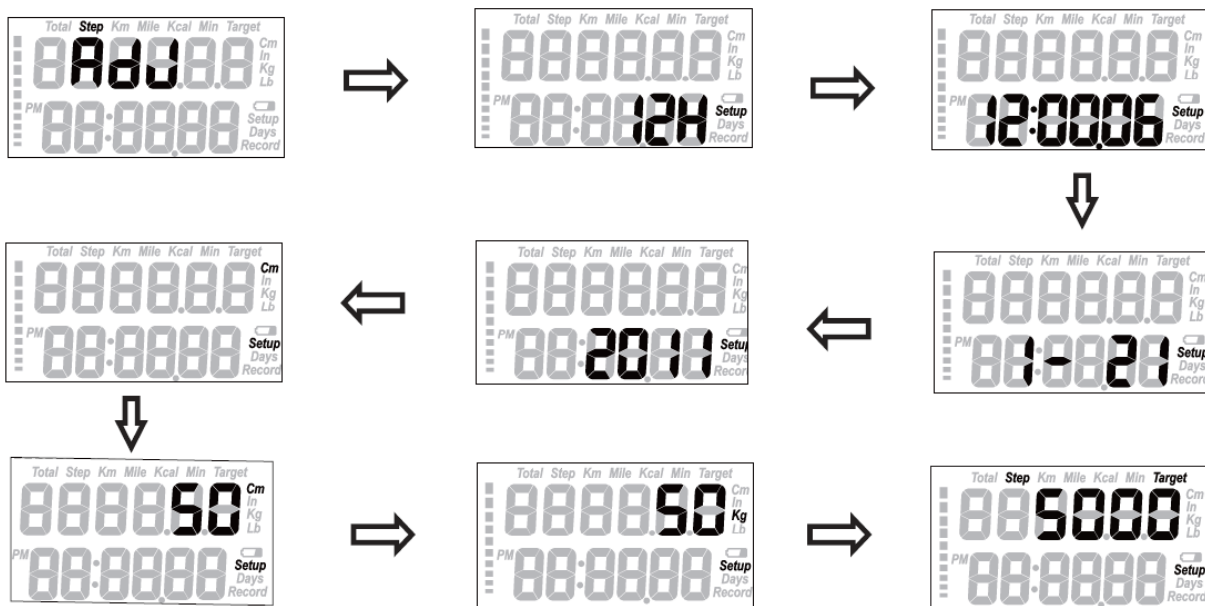

Press MODE to enter into STEP mode. Press and hold the SET button for 2 seconds to enter SETUP mode as follows: 12-24 Hour Format / Seconds / Hours / Minutes / Month / Day / Year / Measurement Units / Stride / Weight / Target Steps.

Press RESET button to increase the setting value, while Press MODE button to decrease; pressing and holding the button will change the number rapidly.

When the value is correct, press SET to move to next. Continue to press SET and change values as required until the pedometer returns to STEP mode.

There are 10 icons which show the percentage of your step to the target steps on the left side of LCD screen. When you reach target steps (100%). The icon will be full of 10 icons and will flash with an alarm for 30 seconds. The default goal is 5000 steps, you can change your target steps to reflect your fitness goals.

NOTE: The pedometer will automatically back to STEP mode if there is no input for 10 seconds in the SETUP mode.

CALCULATING STRIDE LENGTH

In order to calculate accurate DISTANCE traveled, you need to measure and input your stride length.

How to calculate your stride length:

To properly calculate your stride length, measure a predetermined distance in feet. Correct stride distance is defined as a tip of your foot to another one. To measure the correct average stride distance, divide the total distance of ten steps you walked / run by the number of step (10).

Calculate the stride distance in the following way: You walk 6.2 meters, 6.2m (total distance) / 10 (number of steps) = 0.62m (62cm).

NOTE: Unlike the conventional pedometer, this pedometer using a 3D motion sensor that can detect fine body step movement without mechanical sensor, so no rattle sound will create.

NOTE: To avoid inaccurate counting, the pedometer only will show the number of steps taken after continuous steps for 5 seconds, This means that the pedometer won't display the number taken during the first 5 seconds you walk. All the steps taken will be counted and displayed 5 seconds afterward.

OPERATING INSTRUCTIONS

STEP MODE



- The default mode for the device is **Step**.
- In STEP mode, the first line display the total number of steps taken that day.
- The time in 12-Hour or 24-Hour format is displayed at the bottom of LCD screen.
- Press and hold SET button for 2 seconds to enter into Time/Weight/Strides/Target SETUP mode.
- Press and hold RESET button for 2 seconds to clear the data.
- Steps taken, distance traveled, calories burned, total exercise time will be saved to MEMORY mode up to 30 days and cleared to zero at midnight automatically.

DISTANCE MODE



- Press MODE to enter into **Km/Mile**.
- Press and hold RESET button for 2 seconds to clear the data.

CALORIES MODE



- Press MODE to enter into **Kcal**.
- Press and hold RESET button for 2 seconds to clear the data.

EXERCISE TIME MODE



Press MODE to enter into **Min**.

Press and hold RESET button for 2 seconds to clear the data.

MEMORY MODE



- Press MODE to enter into **Record**.
- Press SET button to recall the data as follows: Step / Distance / Calories / Exercise Time.
- Press RESET button to scroll through the days.

TOTAL DATA MODE



- Press MODE to enter into **Total**.
- In this MODE, the top number displays the total accumulated data in the past few days.

- Press SET to recall total accumulated data as follows: Step / Distance / Calories / Exercise Time.
- Press and hold RESET button for 2 seconds to clear the data.

ALARM MODE



- Press MODE to enter into **ALM**.
- Press and hold SET button for 2 seconds to set the alarm.
- Press RESET button to increase the value, while press MODE button to decrease the value.

RESETTING THE PEDOMETER

There are two different ways to RESET your pedometer: DAILY RESET and FULL RESET

To perform a DAILY RESET, Press & Hold RESET for 2 seconds while in STEP, DISTANCE, CALORIES or EXERCISE TIME MODE. The data for the current day is erased.

To perform a FULL RESET, Press & Hold RESET for 2 seconds while in TOTAL MEMORY MODE to erase all accumulated data and reset the pedometer to factory fresh condition.

NOTE: Reset any of the step, distance, calories burned, exercise time data will cause all data mentioned above for current day being erased.

USB CONNECTION

If you want to upload the data to your PC, firstly you need to install the driver from the CD to your computer.

After installed the pedometer driver, plug the supplied USB cable into the USB port and connect it to your computer.



1. Run the software.
2. For the first time to use, you are required to register your pedometer in the software by clicking "Create New Profile".
3. Log into the system with your user name and password.

UPLOADING YOUR DATA

Here is main screen of the system and its fiction.

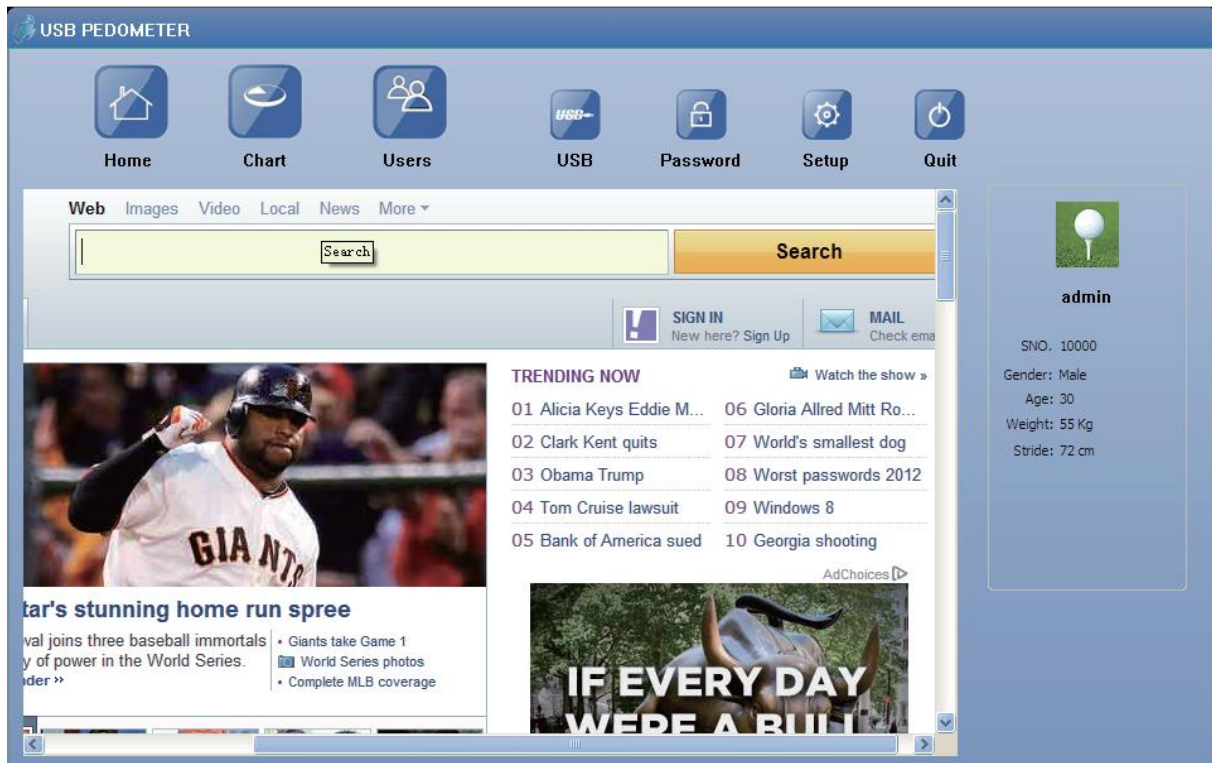

Home: Web browser

Chart: To view your workout data in various mode

Users: To manage different user accounts who registered in the system

USB: To export pedometer data to PC or synchronize profile between PC and pedometer

Password: To change password or permission

Quit: Quit the system

BATTERY REPLACEMENT

WE STRONGLY RECOMMEND TAKING YOUR PEDOMETER TO A LOCAL JEWELER STORE TO HAVE BATTERY REPLACED TO AVOID POSSIBILITY OF PERMANENTLY DAMAGE OF THE PEDOMETER.

1. Take the pedometer out of silicone set, then remove the battery cover.
2. Remove the exhausted battery from the unit, and inset a new one. Make sure the battery positive (+) side point to the battery compartment cover.
3. Replace the cover on the battery compartment

CARE AND MAINTENANCE & CLEARING

- Do not disassemble the pedometer. If in need of repair, refer to the warranty section of this manual.
- Do not subject the device to extreme shocks (do not drop on the floor).
- Do not expose the device to strong chemicals such as gasoline, clean solvents, acetone, alcohol, or insect repellents, as they may damage the device's seal, case and finish.

- Store the product in a dry place when you are not using it.
- Leaky batteries can damage the device. Remove the battery when the device will not be used for a long time.
- To avoid accidental strangulation, keep the pedometer out of reach of young children.
- The operation environment of the pedometer must be free from shocks, magnetic fields, electrical noise and strong vibration.
- Do not immerse the product in water as this will result in damage to it.
- It could be cleaned with a lightly moistened cloth. Apply mild soap to the area if there are stubborn stains or marks.

TERMS AND CONDITIONS OF WARRANTY, WARRANTY CLAIMS

General Conditions of Warranty and Definition of Terms

All Warranty Conditions stated hereunder determine Warranty Coverage and Warranty Claim Procedure. Conditions of Warranty and Warranty Claims are governed by Act No. 40/1964 Coll. Civil Code, Act No. 513/1991 Coll., Commercial Code, and Act No. 634/1992 Coll., Consumer Protection Act, as amended, also in cases that are not specified by these Warranty rules.

The seller is SEVEN SPORT s.r.o. with its registered office in Borivojova Street 35/878, Prague 13000, Company Registration Number: 26847264, registered in the Trade Register at Regional Court in Prague, Section C, Insert No. 116888.

According to valid legal regulations it depends whether the Buyer is the End Customer or not.

“The Buyer who is the End Customer” or simply the “End Customer” is the legal entity that does not conclude and execute the Contract in order to run or promote his own trade or business activities.

“The Buyer who is not the End Customer” is a Businessman that buys Goods or uses services for the purpose of using the Goods or services for his own business activities. The Buyer conforms to the General Purchase Agreement and business conditions to the extent specified in the Commercial Code.

These Conditions of Warranty and Warranty Claims are an integral part of every Purchase Agreement made between the Seller and the Buyer. All Warranty Conditions are valid and binding, unless otherwise specified in the Purchase Agreement, in the Amendment to this Contract or in another written agreement.

Warranty Conditions

Warranty Period

The Seller provides the Buyer a 24 months Warranty for Goods Quality, unless otherwise specified in the Certificate of Warranty, Invoice, Bill of Delivery or other documents related to the Goods. The legal warranty period provided to the Consumer is not affected.

By the Warranty for Goods Quality, the Seller guarantees that the delivered Goods shall be, for a certain period of time, suitable for regular or contracted use, and that the Goods shall maintain its regular or contracted features.

The Warranty does not cover defects resulting from:

User’s fault, i.e. product damage caused by unqualified repair work, improper assembly, insufficient insertion of seat post into frame, insufficient tightening of pedals and cranks

Improper maintenance

Mechanical damages

Regular use (e.g. wearing out of rubber and plastic parts, joints etc.)

Unavoidable event, natural disaster

Adjustments made by unqualified person

Improper maintenance, improper placement, damages caused by low or high temperature, water, inappropriate pressure, shocks, intentional changes in design or construction etc.

Warranty Claim Procedure

The Buyer is obliged to check the Goods delivered by the Seller immediately after taking the responsibility for the Goods and its damages, i.e. immediately after its delivery. The Buyer must check the Goods so that he discovers all the defects that can be discovered by such check.

When making a Warranty Claim the Buyer is obliged, on request of the Seller, to prove the purchase and validity of the claim by the Invoice or Bill of Delivery that includes the product's serial number, or eventually by the documents without the serial number. If the Buyer does not prove the validity of the Warranty Claim by these documents, the Seller has the right to reject the Warranty Claim.

If the Buyer gives notice of a defect that is not covered by the Warranty (e.g. in the case that the Warranty Conditions were not fulfilled or in the case of reporting the defect by mistake etc.), the Seller is eligible to require a compensation for all the costs arising from the repair. The cost shall be calculated according to the valid price list of services and transport costs.

If the Seller finds out (by testing) that the product is not damaged, the Warranty Claim is not accepted. The Seller reserves the right to claim a compensation for costs arising from the false Warranty Claim.

In case the Buyer makes a claim about the Goods that is legally covered by the Warranty provided by the Seller, the Seller shall fix the reported defects by means of repair or by the exchange of the damaged part or product for a new one. Based on the agreement of the Buyer, the Seller has the right to exchange the defected Goods for a fully compatible Goods of the same or better technical characteristics. The Seller is entitled to choose the form of the Warranty Claim Procedures described in this paragraph.

The Seller shall settle the Warranty Claim within 30 days after the delivery of the defective Goods, unless a longer period has been agreed upon. The day when the repaired or exchanged Goods is handed over to the Buyer is considered to be the day of the Warranty Claim settlement. When the Seller is not able to settle the Warranty Claim within the agreed period due to the specific nature of the Goods defect, he and the Buyer shall make an agreement about an alternative solution. In case such agreement is not made, the Seller is obliged to provide the Buyer with a financial compensation in the form of a refund

**SEVEN SPORT s.r.o.**

Sídlo: Bořivojova 35/878, 130 00, Praha 3, ČR
Centrála: Dělnická 957, 749 01 Vítkov
Reklamacie a servis: Čermenská 486, 749 01 Vítkov

IČO: 26847264
DIČ: CZ26847264
Telefon: +420 556 300 970
Mail: eshop@insportline.cz
reklamacie@insportline.cz
servis@insportline.cz
Web: www.insportline.cz

SK**inSPORTline s.r.o.**

Centrála, reklamácie, servis: Električná 6471, 911 01 Trenčín, SK

IČO: 36311723
DIČ: SK2020177082
Telefón: +421(0)326 526 701
Mail: objednavky@insportline.sk
reklamacie@insportline.sk
servis@insportline.sk
Web: www.insportline.sk