



**USER MANUAL – EN**  
**IN 8052 Vibrogym inSPORTline Katrina SE**



**CONTENTS**

PARTS ..... 3  
SAFETY PRECAUTIONS ..... 4  
MAINTENANCE ..... 5  
ASSEMBLY STEPS ..... 6  
WARNING AND NOTICE ..... 8  
PRODUCT INSTALLATION ..... 8  
CONSOLE AND COLUMN DISPLAY OPERATION ..... 10  
EXERCISE POSITIONS ..... 22  
EXPLODED DRAWING ..... 28  
PARTS LIST ..... 28  
TERMS AND CONDITIONS OF WARRANTY, WARRANTY CLAIMS ..... 30

## PARTS



Read all precautions and instructions in this manual before using this equipment. Save this manual for future reference.

## **SAFETY PRECAUTIONS**

**Thank you for your purchasing our products. Even though we go to great efforts to ensure the quality of each product, occasional errors, and /or omissions do occur. In any event should you find this product to be defective or missing a part please contact your place of purchase.**

**Be sure to read the entire manual before assembly and operation. Also, please note following safety precautions:**

1. This appliance is not intended for use by persons (including children) with reduced physical, sensory or mental capabilities, or lack of experience and knowledge, unless they have been given supervision or instruction concerning use of the appliance by a person responsible for their safety.
2. Children should be supervised to ensure that they do not play with the appliance. Children should keep away from the vibration plate at all time.
3. If the supply cord is damaged, it must be replaced by the manufacturer, its service agent or similarly qualified persons in order to avoid a hazard.
4. Before beginning any exercise program, consult your personal physician. If you experience any pain or tightness in your chest, irregular heartbeats, shortness of breath, faintness or other unusual discomfort while exercising, stop and consult your physician before continuing.
5. Do not insert any object into any openings.
6. No person weighing over 180 kilograms should use this product.
7. Only one person at a time should use this equipment.
8. Always use this vibration plate on a clear and level surface. Do not use outdoors or near water.
9. Leave the machine till it stops.
10. Do not use the machine, when you use aerobic equipment or spray.
11. Inspect your machine prior to exercise to ensure that all nuts and bolts are fully tightened.
12. Turn off the power switch after use.
13. User is suggested to use 10-15 minutes a day in order to obtain the best exercise result.
14. User is suggested to stretch or warming up body before using this machine. Start your exercise slowly and increase intensity of exercise gradually.

### **CONTRAINDICATIONS:**

- Pregnancy
- Acute thrombosis conditions
- Cardio-vascular disease
- Fresh wounds resulting from an operation or surgical intervention
- Hip- and knee replacements
- Acute hernia, discopathy, spondylolysis
- Diabetes and epilepsy
- Heavy migraine
- Wearing a pacemaker and tumor

## MAINTENANCE

Regular maintenance to keep the machine running in the best condition:

1. Please pay attention when in installation and please gently move and place, when the machine is tilted in contact with the ground, please use a soft material to pave the way so as not to scratch the surface of the paint between equipment and hard objects to avoid collision, direct damage to the equipment surface.
2. Please use tool or have more than two labors to move the equipment, do not directly move the equipment chassis and the handle bar to avoid damage to the arm and feet.
3. Equipment should be placed on a smooth and even floor, preferably on a carpeted or following treatment of non-slip dry room. This prevents equipment corrosion, wear and tear.
4. In some parts of the equipment should be kept with constantly maintenance. Use a neutral detergent after use or use damp cloth on machine surface. Do not use methanol, ethanol, amino acid-based cleaning agent or.
5. Regular check equipment parts to see if loose screws, if any parts is shaking or unstable is found, immediately locking, if still cannot be resolved, may notify the vendor for processing.
6. Please use Damp cloth for clearing after use on the device display and other surfaces and exterior handrails, and cleaning, especially the serious part of a drop of sweat wipe, conditional Club After you can smear on the part of the equipment, wipe it again to avoid stripping.
7. Do not move the products and do not touch machine inner parts as not to damage the power supply unit and the risk of electric shock.
8. On operating, if there are no unusual sound, or if any, equipment and facilities for damage or malfunction, immediately stop using, so as not to expand the extent of damage, and notify the your vendor to check and maintenance.

## ASSEMBLY STEPS

### STEP 1

Please take the base frame and column out of box and connect cables.

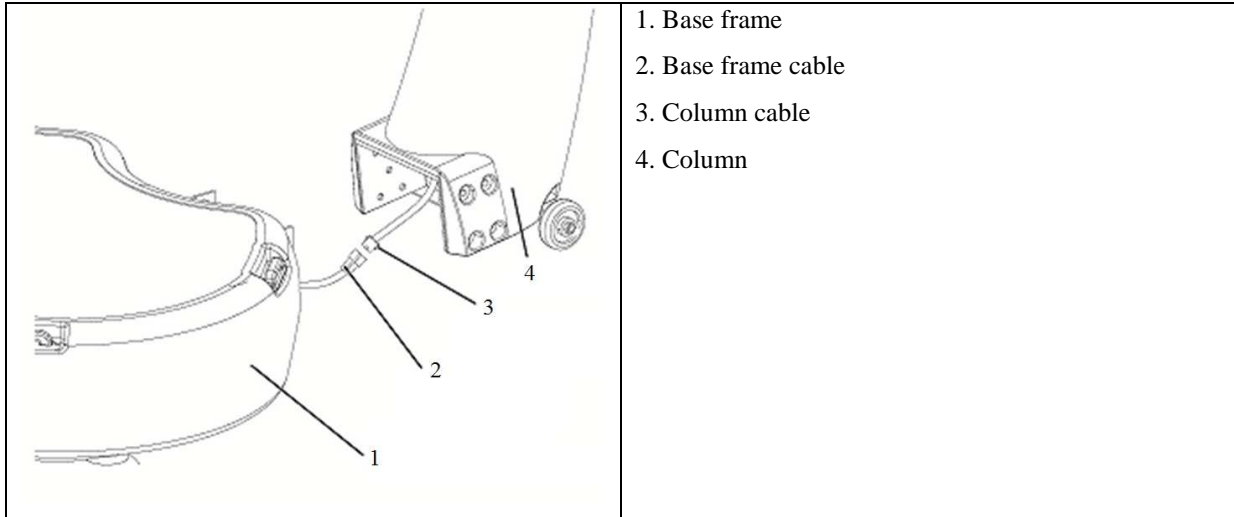

### STEP 2

Please assembling post column and base frame with bolts / spring washers and washers to tight up. Please be aware not to cut the cable.

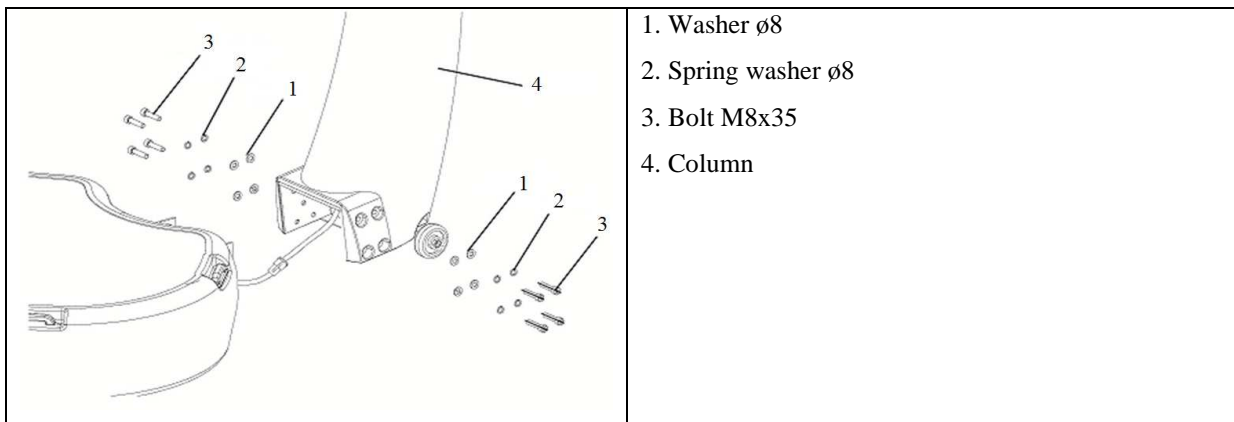

### STEP 3

- A. Please have the handle bar go through the column, and please have the handle bar cover assembling on the handle bar edge with M6 bolts to tight up.
- B. Please have the washers and bolts assembling on the column.

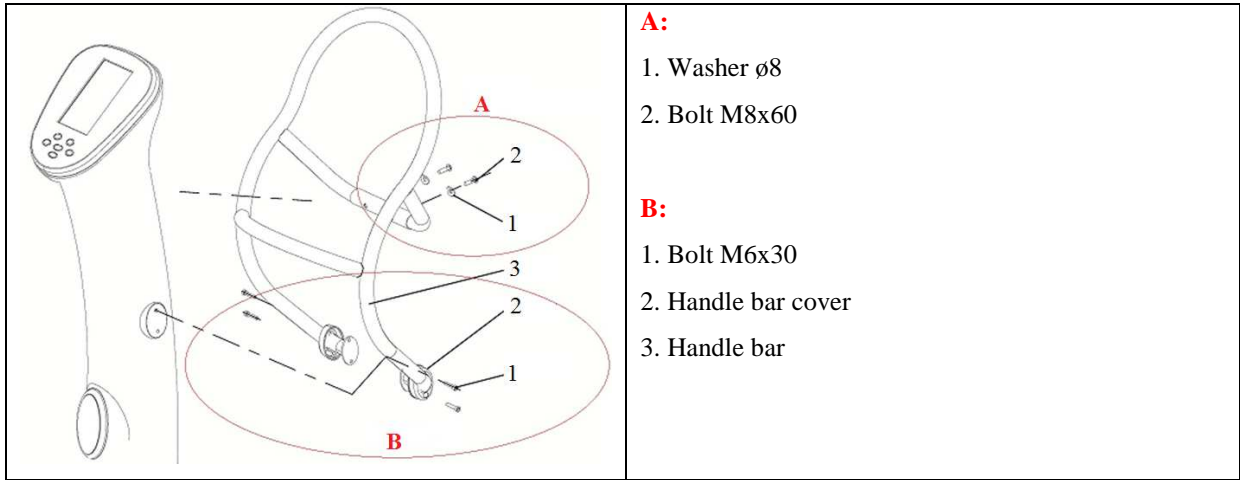

#### STEP 4

Please connect the power cord on the back side of column.

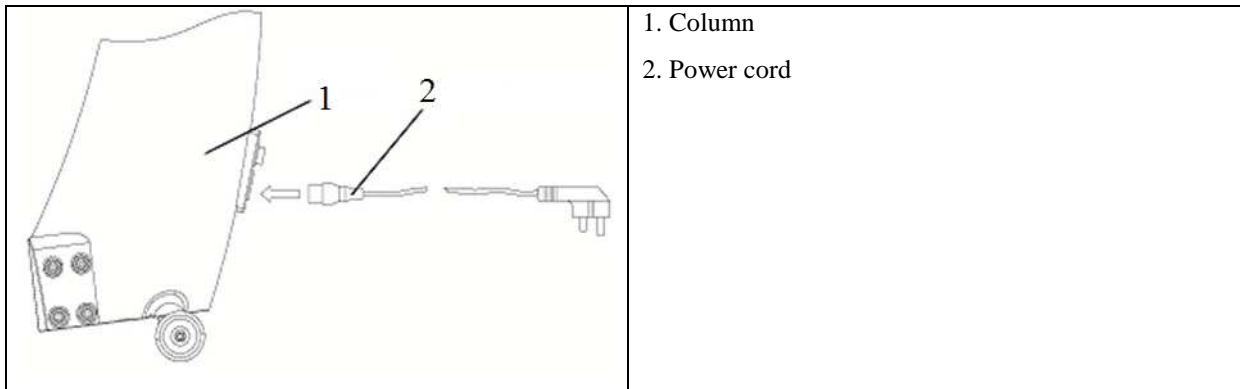

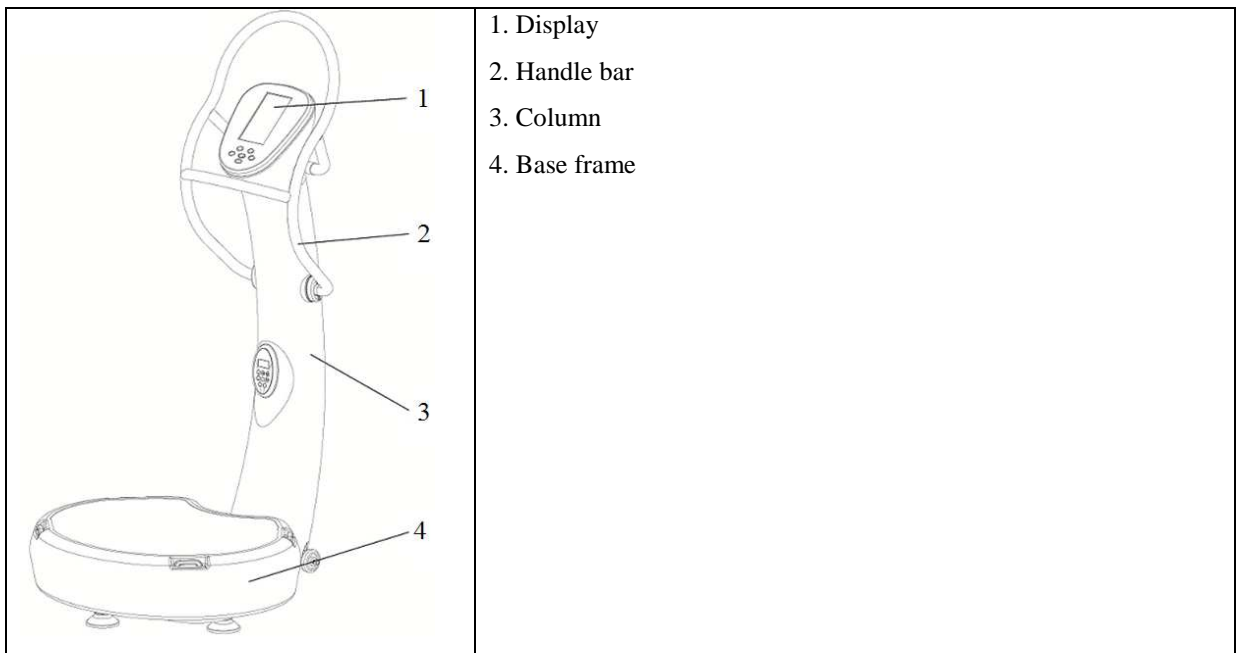

**Assembling completed.**











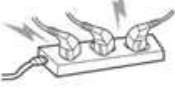

## WARNING AND NOTICE

- **Warning and notice for your safety**

The below is written for your safety, please read carefully and use the product properly.

 CAUTION	Follow instructions or risk injury	 !	This product is made for AC 220V, 50Hz/60Hz	 ⊘	Do not disassemble or attempt to repair
 WARNING	Follow instructions or risk injury	 ⊘	Do not use under these conditions	 ⊘	Do not touch

- **Notice of electrical power and the way of using**

	 ⊘	Do not use a damaged or faulty electrical plug or socket.
	 ⊘	Use AC 220V, 50Hz/60Hz power supply. Avoid using a multi-board power device.
	 ⊘	Do not touch power supply with wet hands.
	 !	Remove water or dust from power cord with a clean dry cloth.
	 ⊘	Do not place the product by a heat source. Avoid naked flames.

A patient and unhealthy person should exercise with this product after talking with a doctor.

If you feel no good during using this product, must stop using. Continuous using with no good condition could cause the accident or serious danger to your body.

## PRODUCT INSTALLATION



Place the product at least 1m from walls and furniture

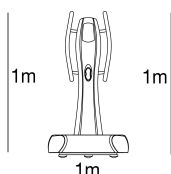





Place on a flat surface

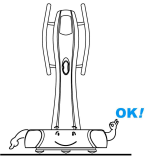

Do not disassemble or attempt to repair the product.



Children and the elderly must be supervised when using this product.



During using this product children should be kept away from this product.



Do not use if the product is wet.



Do not place hands, feet or other body parts under the product.

An accident happen caused by user's own discretion without reading this manual, user can't blame to the company.

Please read this manual for your safety.

# CONSOLE AND COLUMN DISPLAY OPERATION



## TIME

Time displays from 00:20 to 10 minutes, 10 sec. UP and DOWN adjustment.



## SPEED/HZ

From 20hz to 60hz, 1 hz UP and DOWN adjustment.

Hz amplitude setting for High and Low



## PRESET PROGRAMS

8 Preset programs:

P1: STRETCHING AND RELAXATION

P2: WHOLE BODY EXERCISE

P3: UPPER BODY EXERCISE



P4: LOWER BODY EXERCISE





P5-P8: ADVANCE EXERCISE PROGRAMS

## USER PROGRAMS

3 User programs setting selection combinations





## BUTTON OPERATION

	<p>START – Push START to Start the settings or selected programs.</p>		<p>Press ENTER button to confirm setting and go to next step.</p>
---	---	---	---

	<p>During workout: Push to increase speed</p> <p>During setting: Push to increase TIME, Speed HZ, H/L and Program selection.</p>		<p>During setting: Push the RETURN to go back last setting or to go back to last page.</p>
	<p>During workout: Push to decrease speed.</p> <p>During setting: Push to decrease TIME, Speed HZ, H/L and Program selection.</p>		<p>During workout: Push PAUSE / STOP to pause the exercise or go back last page.</p>



## COLUMN DISPLAY OPERATION

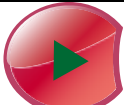

	<p>During workout: Push to decrease speed.</p> <p>During setting: Push to decrease TIME, Speed HZ, H/L and Program selection.</p>		<p>During setting: Push RETURN to go back last setting or to go back to last page.</p>
	<p>During workout: Push to increase speed.</p> <p>During setting: Push to increase TIME, Speed HZ, H/L and Program selection.</p>		<p>Press ENTER button to confirm setting and go to next step.</p>
	<p>START – Push START to Start the settings or selected programs.</p>		

	<p>During workout: Push PAUSE / STOP to pause or stop the exercise or go back last page.</p>		
---	--	--	--

**OPERATING INSTRUCTIONS**

	<p><b>OPENING</b></p> <ol style="list-style-type: none"> <li>1. Press UP to view last page.</li> <li>2. Press down to view next page.</li> <li>3. Each page will remind for 10 seconds and go to next page.</li> <li>4. After Warning messages, display will go to MENU page for program selection. Press DOWN for quick enter to MENU page.</li> </ol>
	<p><b>MENU</b></p> <ol style="list-style-type: none"> <li>1. Four Modes: MANUAL, PRESET, USER, PRECAUTIONS.</li> <li>2. Press UP DOWN to select each programs.</li> <li>3. Press ENTER to enter each program.</li> </ol>

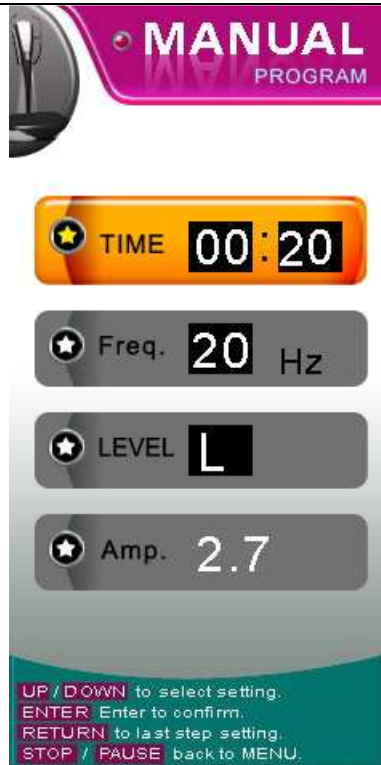

### MANUAL PROGRAM

1. Press UP / DOWN to adjust Time Frequency and Level.
2. Press ENTER to confirm the setting and go to next step.
3. Press RETURN to go back last setting.
4. After TIME, FREQ. and LEVEL set, MANUAL PROGRAM SETTING COMPLETED.
5. Press START to start this exercise.
6. Press STOP/PAUSE back to MENU.
7. TIME from 00:20~10:00mins, interval 10 seconds, up and down.
8. HZ range:20~60:1 Hz up and down during operating, speed is adjustable by press UP and DOWN for 1 hz interval.



### 8 PRESET PROGRAMS

1. P1: Stretching and relaxation  
 P2: Whole body exercise  
 P3: Upper body exercise  
 P4: Lower body exercise  
 P5-P8: Advance exercise program
2. Press UP / DOWN to view each preset program's exercise positions and total workout time.
3. Press Enter to go in Preset program preview.
4. START to start exercise directly.
5. RETURN back to MENU.



### PRESET PREVIEW PROGRAM

1. Press UP / DOWN or ENTER to view each exercise steps.
2. Press RETURN to back to last page PRESET PROGRAM.
3. Press START to start the exercise.
4. During operating, speed is adjustable by press UP and DOWN for 1 hz interval.



### 3 USER PROGRAMS

1. Press UP / DOWN to view each user program's exercise positions and total workout time.
2. Press ENTER for User program preview.
3. Press RETURN back to MENU.
4. Press START to start this exercise.

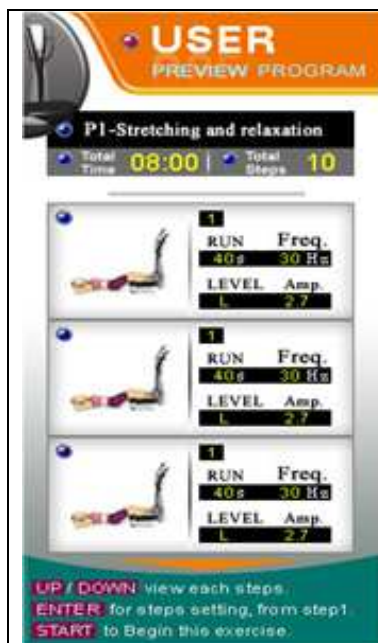

### 10 steps User Preview Programs

1. Press UP/ DOWN to view each User setting steps.
2. Press ENTER to edit each User programs setting.
3. Press RETURN back to User Program.
4. Press START to start this exercise.



### User Edit Program: 10 steps setting

1. Freq. setting by using UP DOWN to adjust hz level, press ENTER to confirm.
2. Please select Pose workout position by UP DOWN to view each workout exercise position, press ENTER to confirm. Available workout positions are subject to Hz level.
3. Please select Level H or L by using UP DOWN, press ENTER to confirm.
4. Please select each interval steps RUN time by UP / DOWN to adjust and press ENTER to confirm.
5. Press RETURN back to last data setting
6. Repeat each steps setting for total 10 steps. After entered all settings, message showed: **User program setting completed.**
7. Press START to start the exercise.
8. Press STOP back to User preview program and all entered setting will be saved.
9. User total workout time will be added up by each steps setting.





### WORKOUT Display:

1. During workout HZ level can be adjusted by UP DOWN, 1 hz up.
2. Quick button on remote controller by press 30 hz, 40 hz , 50hz , the hz level will automatic goes to 30, 40, 50hz.
3. Preset and user program interval RUN time will be countdown until 0 and go into REST mode for 15 seconds.  
  
After total workout time countdown to 0, program is completed, please press START to run this program again or press RETURN back to Program.
4. During workout if you wish to pause, please press STOP/ PAUSE to pause the exercise and press RETURN back to Program page, or press START to continue this workout program.
5. Please follow up the workout exercise position and read each workout position instruction for more information and workout tips.













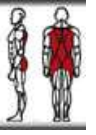

	<p><b>REST mode:</b></p> <ol style="list-style-type: none"> <li>1. Each Rest mode is 15 seconds.</li> <li>2. REST mode is designed for the interval exercise so the user could standby for next position and the next workout position picture will be showed on display during the Rest Mode.</li> </ol>
	<p><b>PRECAUTIONS</b></p> <ol style="list-style-type: none"> <li>1. Please read the entire precautions WARNING message before attempt to use this machine.</li> <li>2. Please press UP DOWN to go last and next page.</li> <li>3. Each page remind 10 seconds and automatically go to next page.</li> <li>4. Press RETURN back to MENU page.</li> </ol>

## PRESET PROGRAMS

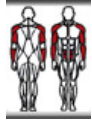

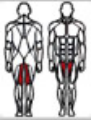

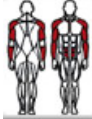





P1-STRETCHING AND RELAXATION							P2-WHOLE BODY EXERCISE						
No	Workout pose	Muscle group	RUN	Freq.	LEVEL	Amp	No	Workout pose	Muscle group	RUN	Freq.	LEVEL	Amp.
1			40	30	L	2.3	1			60	25	L	2.5
2			55	35	L	2.0	2			55	40	L	2.0
3			50	35	L	2.0	3			55	45	H	1.5
4			35	40	L	2.0	4			50	45	H	1.5
5			40	40	L	2.0	5			60	40	H	2.0
6			45	35	L	2.0	6			60	50	L	1.5
7			50	40	L	2.0	7			45	45	L	1.5
8			40	40	L	2.0	8			40	50	L	1.5
9			45	35	L	2.0	9			30	35	L	2.0

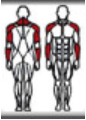

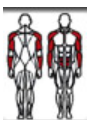











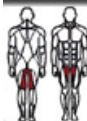



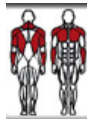



10	Pose27 		50	30	L	2.3	10	Pose27 		25	35	L	2.0
----	---	---	----	----	---	-----	----	---	---	----	----	---	-----

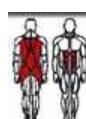









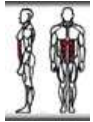

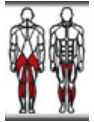

P3-UPPER BODY EXERCISE							P4-LOWER BODY EXERCISE						
No	Workout pose	Muscle group	RUN	Freq.	LEVEL	Amp	No	Workout pose	Muscle group	RUN	Freq.	LEVEL	Amp.
1	Pose18 		40	30	L	2.3	1	Pose02 		60	30	L	2.3
2	Pose15 		35	35	L	2.0	2	Pose21 		55	35	L	2.0
3	Pose17 		40	30	L	2.3	3	Pose09 		50	45	L	1.5
4	Pose12 		45	40	H	2.0	4	Pose08 		50	40	H	2.0
5	Pose14 		35	45	L	1.5	5	Pose20 		45	40	H	2.0
6	Pose11 		35	50	L	1.5	6	Pose07 		45	50	L	1.5
7	Pose10 		45	45	H	1.5	7	Pose19 		55	50	H	1.5
8	Pose13 		50	50	L	1.5	8	Pose23 		50	45	L	1.5

9	Pose31 		50	40	L	2.0	9	Pose22 		30	40	L	2.0
10	Pose32 		45	35	L	2.0	10	Pose24 		40	35	L	2.0

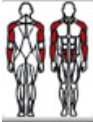

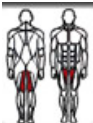

P5-PROGRAM 5							P6-PROGRAM 6						
No	Workout pose	Muscle group	RUN	Freq.	LEVEL	Amp	No	Workout pose	Muscle Group	RUN	Freq.	LEVEL	Amp.
1	Pose02 		60	30	L	2.3	1	Pose05 		45	35	L	2.0
2	Pose03 		55	40	L	2.0	2	Pose08 		55	40	L	2.0
3	Pose18 		40	40	L	2.0	3	Pose26 		40	40	L	2.0
4	Pose25 		50	45	H	1.5	4	Pose25 		35	45	L	1.5
5	Pose14 		35	45	L	1.5	5	Pose04 		45	50	H	1.5
6	Pose09 		60	50	L	1.5	6	Pose11 		35	45	L	1.5
7	Pose19 		55	45	H	1.5	7	Pose30 		35	40	L	2.0

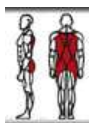





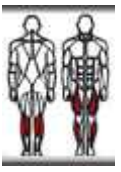

8	Pose08 		60	50	L	1.5	8	Pose18 		40	40	L	2.0
9	Pose31 		30	40	L	2.0	9	Pose21 		50	35	L	2.0
10	Pose24 		35	35	L	2.0	10	Pose24 		40	30	L	2.3

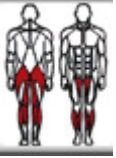







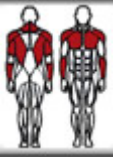

P7-PROGRAM 7							P8-PROGRAM 8						
No	Workout pose	Muscle group	RUN	Freq.	LEVEL	Amp	No	Workout pose	Muscle group	RUN	Freq.	LEVEL	Amp.
1	Pose01 		40	35	L	2.0	1	Pose32 		40	35	L	2.0
2	Pose19 		55	35	L	2.0	2	Pose21 		55	40	L	2.0
3	Pose10 		30	40	L	2.0	3	Pose25 		30	45	L	1.5
4	Pose06 		35	40	H	2.0	4	Pose26 		35	45	H	1.5
5	Pose14 		35	45	L	1.5	5	Pose11 		40	40	L	2.0
6	Pose12 		40	50	L	1.5	6	Pose12 		40	45	L	1.5

7	Pose25 		55	45	H	1.5	7	Pose04 		45	50	H	1.5
8	Pose08 		60	45	L	1.5	8	Pose09 		50	45	L	1.5
9	Pose32 		35	35	L	2.0	9	Pose06 		45	40	L	2.0
10	Pose22 		35	35	L	2.0	10	Pose27 		45	35	L	2.0







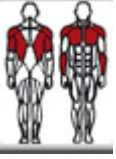



## EXERCISE POSITIONS



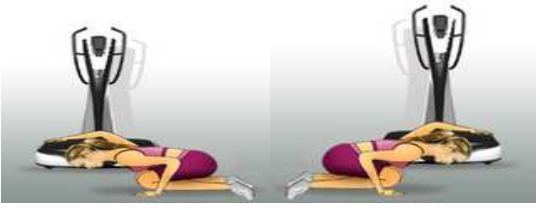

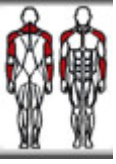



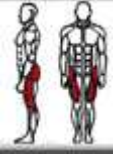

Pose01 (UP and DOWN) 		Stand on toes with slightly bent at the hips and knees with contracted abdominal.
Pose02 		Standing with feet shoulder width apart. Keeping the back straight and knees slightly bent and flexing hips until you feel desired tension in your quadriceps, hips.
Pose03 		Standing with legs width apart. Sit back and gently bend the legs until you feel the tension in the back, buttock, quadriceps and inner thigh area.



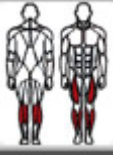



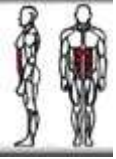

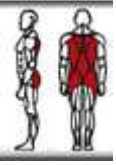

<p>Pose04</p> 		<p>Feet standing outward in the position wider than shoulder width bend the legs and sit back; you should feel tension inner thigh and hamstring.</p>
<p>Pose05 (L and R)</p> 		<p>Standing forward with one leg in front of the other. Front leg should slightly bent, keep the back leg straight while pushing the rear heel into the plate with tension in your calves.</p>
<p>Pose06</p> 		<p>Hips pushed backwards with legs straight but not locked. Holding the handles let your upper torso drop as far forward as possible for stretch your buttock and hamstring muscle groups.</p>
<p>Pose07 (L and R)</p> 		<p>Standing with one foot on the plate lower your body with contracted abdominals.</p>
<p>Pose08 (L and R)</p> 		<p>Keeping leg on the plate straight, bend and lean another leg. Lower your hips and sit back. This exercise will stretch the insides of your thighs.</p>

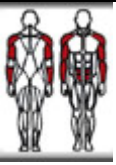
<p>Pose09 (L and R)</p> 		<p>Step one foot on the plate while another feet on the floor. Bent knees and ankles and lower your body slowly until you feel tension in the hamstrings.</p>
<p>Pose10</p> 		<p>Place elbows on the plate with contracted abdominals, gently push your hips upward slowly. You should feel tension in your abdominal region.</p>
<p>Pose11 (UP and DOWN)</p> 		<p>Place hands on the mat with shoulder width apart and bend elbow to push up and lower body with contracted abdominals.</p>
<p>Pose12 (L and R)</p> 		<p>Lay on side with one foot directly behind the other, place flexed elbow on the plate while pushing your hips upward with contracted abdominals at the same time.</p>
<p>Pose13</p> 		<p>Slowly flex shoulder to comfortable range with elbow on the plate, pulling hips away from hands horizontally.</p>
<p>Pose14 (UP and DOWN)</p> 		<p>Keep your hips close to the edge of plate and place hands on the plate with shoulder width apart. Pushing your hips upward and downward with bent elbows.</p>

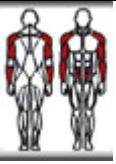

<p>Pose15</p> 		<p>Placing hands on the plate shoulder width apart. Keep back straight with contracted abdominals.</p>
<p>Pose16</p> 		<p>Sit on the floor and place Mat between plate and your back with your legs bent. Place your elbows on plate for balance. You could adjust your back position for different contact point.</p>
<p>Pose17 (L and R)</p> 		<p>Place arm on plate with elbow bent; gently lower your body to the floor until tension felt in chest muscles.</p>
<p>Pose18 (UP and DOWN)</p> 		<p>Position elbows on the plate with shoulder width apart, legs and back straight, head raised. Gently push your bent arms toward the Vibration plate, then return to the starting position.</p>
<p>Pose19 (L and R)</p> 		<p>Place one shin on the plate and push hips and pelvis forward while keeping your upper body and back straight until the tension felt in the hip and belly.</p>
<p>Pose20 (UP and DOWN)</p> 		<p>Place feet on the plate with extra stepper or mat for upper body support, push hips upward while contract abdominals.</p>

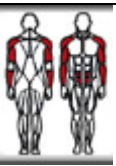
<p>Pose21 (L and R)</p> 		<p>Lay sideways on plate with knees bent and elbow touches the floor to support your body.</p>
<p>Pose22 (L and R)</p> 		<p>Place inner thigh on plate slightly bend while body resting on the floor.</p>
<p>Pose23</p> 		<p>Lying on plate in prone position with front of thighs on the plate with extra step or Mat for upper body support. The Mat or Step should be in the same height as the vibration plate</p>
<p>Pose24</p> 		<p>Place both calves on the plate, toes toward up while upper body rest on the floor easily and relax.</p>
<p>Pose25</p> 		<p>Hands under your head for support, push your upper body toward your legs with contracted abdominals. Ensure your buttocks and lower back do not lose contact with the mat.</p>
<p>Pose26 (UP and DOWN)</p> 		<p>Hands in front of your chest, with contracted abdominals and one leg lower stretching straight for more tension on abdominals.</p>

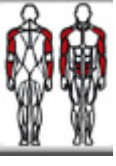
<p>Pose27</p> 		<p>Placing Mat under your hips with knees bent. Relax your upper body and gently bent forward.</p>
<p>Pose28</p> 		<p>Hold straps with both bent elbows in the same level, adjusting the tension by pull the straps.</p>
<p>Pose29</p> 		<p>Hold straps with both arms straight in the same level, adjusting the tension by pull the straps.</p>
<p>Pose30</p> 		<p>Hold the straps straight at shoulder height, abduct arms to desired position. Pull tightly to increase the tension. You should feel tension in the shoulders and biceps.</p>
<p>Pose31</p> 		<p>Pull the straps upward and pull your arms backwards with tension and you should feel tension in your arm, upper back.</p>
<p>Pose32 (L and R)</p> 		<p>Hand hold to one strap with arm at the side outwardly rotate shoulder and let arm extend back; lean forward slightly.</p>

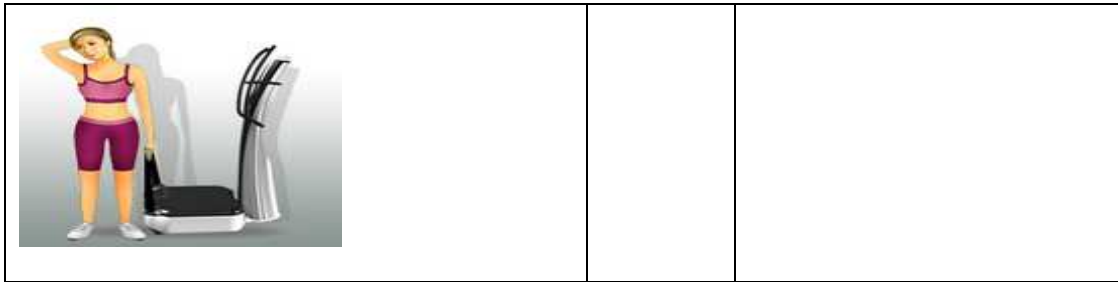

## EXPLODED DRAWING

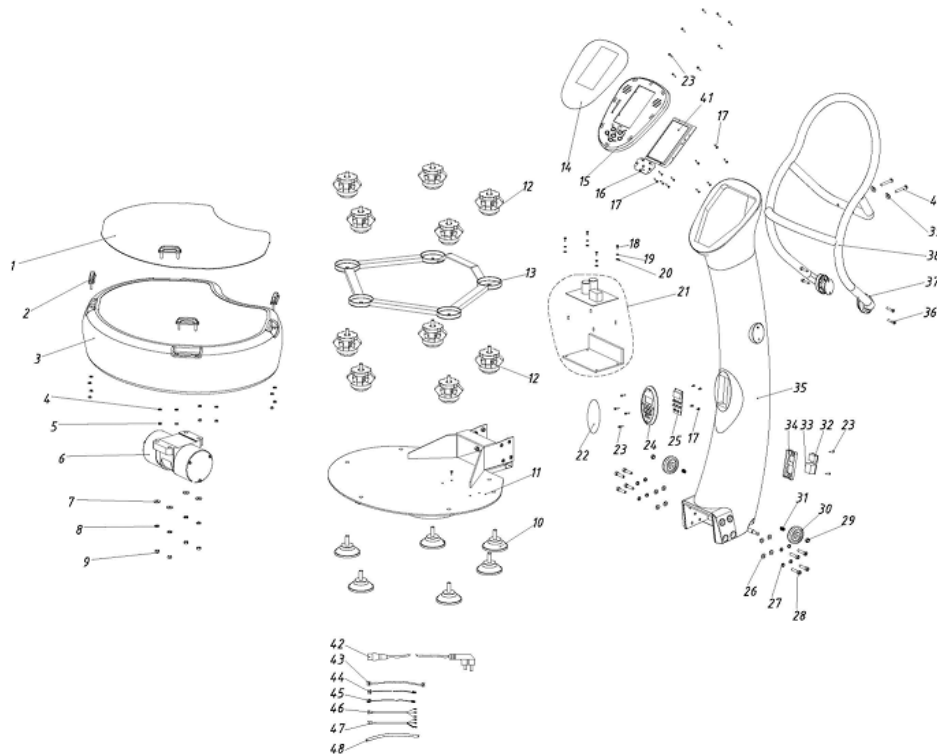

## PARTS LIST

NO.	Specification	QTY
1	Non slip sticker	1
2	Straps holder	4
3	Frame housing	1
4	Washer	8
5	Bolt	8
6	Motor	1
7	Washer	4
8	Spring washer	4
9	Bolt	4
10	Rubber feet	6
11	Steel frame	1

12	Rubber cushion	10
13	Support frame	1
14	Display sticker	1
15	Upper display housing	1
16	Button PCB	1
17	Screws	21
18	Screws	4
19	Spring washer	4
20	Washer	4
21	Inverter	1
22	Column display sticker	1
23	Screws	4
24	Column display housing	1
25	Column display PCB	1
26	Washer	8
27	Spring washer	8
28	Bolt	8
29	Nut	2
30	Transportation wheels	2
31	Tube	2
32	Power switch	1
33	Power socket	1
34	Switch housing	1
35	Post column	1
36	Screws	4
37	Handle bar cap	2
38	Handle bar	1
39	Curve washer	2
40	Bolt	2
41	Display PCB	1
42	Power cord	1
43	Upper cable	1
44	Middle cable	1
45	Lower cable	1
46	AC cable upper	1
47	AC cable lower	1
48	Cable tube	1

# TERMS AND CONDITIONS OF WARRANTY, WARRANTY CLAIMS

## General Conditions of Warranty and Definition of Terms

All Warranty Conditions stated hereunder determine Warranty Coverage and Warranty Claim Procedure. Conditions of Warranty and Warranty Claims are governed by Act No. 40/1964 Coll. Civil Code, Act No. 513/1991 Coll., Commercial Code, and Act No. 634/1992 Coll., Consumer Protection Act, as amended, also in cases that are not specified by these Warranty rules.

The seller is SEVEN SPORT s.r.o. with its registered office in Borivojova Street 35/878, Prague 13000, Company Registration Number: 26847264, registered in the Trade Register at Regional Court in Prague, Section C, Insert No. 116888.

According to valid legal regulations it depends whether the Buyer is the End Customer or not.

“The Buyer who is the End Customer” or simply the “End Customer” is the legal entity that does not conclude and execute the Contract in order to run or promote his own trade or business activities.

“The Buyer who is not the End Customer” is a Businessman that buys Goods or uses services for the purpose of using the Goods or services for his own business activities. The Buyer conforms to the General Purchase Agreement and business conditions to the extent specified in the Commercial Code.

These Conditions of Warranty and Warranty Claims are an integral part of every Purchase Agreement made between the Seller and the Buyer. All Warranty Conditions are valid and binding, unless otherwise specified in the Purchase Agreement, in the Amendment to this Contract or in another written agreement.

## Warranty Conditions

### Warranty Period

The Seller provides the Buyer a 24 months Warranty for Goods Quality, unless otherwise specified in the Certificate of Warranty, Invoice, Bill of Delivery or other documents related to the Goods. The legal warranty period provided to the Consumer is not affected.

By the Warranty for Goods Quality, the Seller guarantees that the delivered Goods shall be, for a certain period of time, suitable for regular or contracted use, and that the Goods shall maintain its regular or contracted features.

### The Warranty does not cover defects resulting from:

User's fault, i.e. product damage caused by unqualified repair work, improper assembly, insufficient insertion of seat post into frame, insufficient tightening of pedals and cranks

Improper maintenance

Mechanical damages

Regular use (e.g. wearing out of rubber and plastic parts, joints etc.)

Unavoidable event, natural disaster

Adjustments made by unqualified person

Improper maintenance, improper placement, damages caused by low or high temperature, water, inappropriate pressure, shocks, intentional changes in design or construction etc.

## Warranty Claim Procedure

The Buyer is obliged to check the Goods delivered by the Seller immediately after taking the responsibility for the Goods and its damages, i.e. immediately after its delivery. The Buyer must check the Goods so that he discovers all the defects that can be discovered by such check.

When making a Warranty Claim the Buyer is obliged, on request of the Seller, to prove the purchase and validity of the claim by the Invoice or Bill of Delivery that includes the product's serial number, or eventually by the documents without the serial number. If the Buyer does not prove the validity of the Warranty Claim by these documents, the Seller has the right to reject the Warranty Claim.

If the Buyer gives notice of a defect that is not covered by the Warranty (e.g. in the case that the Warranty Conditions were not fulfilled or in the case of reporting the defect by mistake etc.), the Seller is eligible to

require a compensation for all the costs arising from the repair. The cost shall be calculated according to the valid price list of services and transport costs.

If the Seller finds out (by testing) that the product is not damaged, the Warranty Claim is not accepted. The Seller reserves the right to claim a compensation for costs arising from the false Warranty Claim.

In case the Buyer makes a claim about the Goods that is legally covered by the Warranty provided by the Seller, the Seller shall fix the reported defects by means of repair or by the exchange of the damaged part or product for a new one. Based on the agreement of the Buyer, the Seller has the right to exchange the defected Goods for a fully compatible Goods of the same or better technical characteristics. The Seller is entitled to choose the form of the Warranty Claim Procedures described in this paragraph.

The Seller shall settle the Warranty Claim within 30 days after the delivery of the defective Goods, unless a longer period has been agreed upon. The day when the repaired or exchanged Goods is handed over to the Buyer is considered to be the day of the Warranty Claim settlement. When the Seller is not able to settle the Warranty Claim within the agreed period due to the specific nature of the Goods defect, he and the Buyer shall make an agreement about an alternative solution. In case such agreement is not made, the Seller is obliged to provide the Buyer with a financial compensation in the form of a refund.



**SEVEN SPORT, s.r.o.**

Borivojova 35/878 130 00 Praha 3, Czech Republic

CRN: 268 47 264, VAT ID: CZ26847264

Orders: +420 556 300 970, objednavky@insportline.cz

Warranty Claims: +420 556 770 190, Mobile: +420 604 853 019, reklamace@insportline.cz

Service: +420 556 770 190, Mobile: +420 604 853 019, servis@insportline.cz

Fax: +420 556 770 192, (Service +420 556 770 191)

Web: www.insportline.cz, www.worker.cz, www.worker-moto.cz



**INSPORTLINĚ, s.r.o.**

Bratislavská 36, 911 05 Trenčín, Slovakia

CRN: 36311723, VAT ID: SK2020177082

Orders: +421(0)326 526 701, +421(0)917 649 192, objednavky@insportline.sk

Warranty Claims: +421(0)326 526 701, +421(0)918 408 519, reklamacie@insportline.sk

Fax: +421(0)326 526 705

Web: www.insportline.sk, www.worker.sk, www.worker-moto.sk

Date of Sale:

Stamp and Signature of Seller: