



**USER MANUAL – EN**  
**IN 7672 Scooter WORKER Pinki**  
**IN 14334 Scooter WORKER Plofi**



**CONTENTS**

SAFETY INSTRUCTIONS..... 3  
    CAUTIONS..... 4  
ASSEMBLY AND FOLDING INSTRUCTIONS ..... 4  
MAINTENANCE ..... 7  
TERMS AND CONDITIONS OF WARRANTY, WARRANTY CLAIMS..... 7

## SAFETY INSTRUCTIONS

Scooter riding can be a hazardous activity. The scooter can and is intended to move and it is therefore possible to get into dangerous situations and/or lose control and/or fall. If such things occur, you can be seriously injured or die. LIKE ANY OTHER MOVING PRODUCT, USING A SCOOTER CAN BE A DANGEROUS ACTIVITY AND MAY RESULT IN INJURY OR DEATH EVEN WHEN USED WITH PROPER SAFETY PRECAUTIONS. USE AT YOUR OWN RISK AND USE COMMON SENSE.

- Always wear safety equipment such as a helmet and protectors of knees, elbows and wrists. Long-sleeves, long pants and lace-up athletic shoes are recommended. Don't ride barefoot or in sandals. Keep shoelaces out of the way of wheels.
- Ride on flat, dry and even ground with no obstacles, gravel or other debris. Do not use shoes with high heels or slippery soles. When riding a scooter, do not wear sunglasses or headphones.
- Do not ride in poor light conditions (at night or in bad visibility conditions) and at wet or icy weather.
- Avoid streets and surfaces with water, sand, gravel, dirt, leaves, sharp bumps, drainage grates and other debris, as surface changes may block the front wheel. Never ride over speed bumps, it is extremely dangerous.
- **Certification:** EN 14619
- **Category:** B
- **Max rider weight:** 50 kg
- Never ride in traffic or on public roads and watch your surroundings for pedestrians, bikers, boarders and skaters.
- Use the trainer in areas free from hazards, such as poles, fire hydrants, curbs, parked cars and traffic.
- **This scooter is not designed for aggressive riding, jumping or other stunts. Do not use it on uneven surfaces (e.g. cobblestones or unpaved roads). Damages caused by improper use are not covered by warranty. Always press the rear fender against the wheel to slow down and stop. The brake will get hot with continuous use, do not touch it after braking.**



### WARNING:

FAILURE TO USE COMMON SENSE AND HEED THE ABOVE WARNINGS FURTHER INCREASES THE RISK OF SERIOUS INJURY. USE AT YOUR OWN RISK AND WITH APPROPRIATE AND SERIOUS ATTENTION TO SAFE OPERATION. USE CAUTION.



### WARNING:

ALWAYS INSPECT THE SCOOTER PRIOR TO RIDING – CHECK THE STEERING SYSTEM AND MAKE SURE ALL COMPONENTS ARE LOCKED PROPERLY AND IN GOOD WORKING CONDITION. Regular checks and proper maintenance will reduce the risk of injury.



### WARNING:

The original equipment supplied at the time of sale was selected on the basis of its compatibility with the frame, fork and all other parts. Certain aftermarket products may or may not be compatible. Do not perform any modifications to the product as it could decrease its safety. All modifications to the product should be done by a qualified service technician.



## WARNING:

CHECK LOCAL LAWS REGARDING SCOOTER USE. Check local laws and regulations to see where and how you may use your scooter legally. The use of a safety helmet may be compulsory.

## CAUTIONS

Read the following instructions carefully before the first use:

1. Check and secure all fasteners before every ride. Always make sure the latches, clamps and spring pins are locked properly. Also check the wheels and bearings.
2. Scooters are meant to be used only in controlled environments free of potential traffic hazards and not on public streets, uneven surface or among pedestrians.
3. The brake cannot guarantee complete safety when riding downhill. It is the responsibility of the rider to adjust his riding speed so that he could stop safely without the risk of falling.

## ASSEMBLY AND FOLDING INSTRUCTIONS

### STEP 1: UNFOLDING

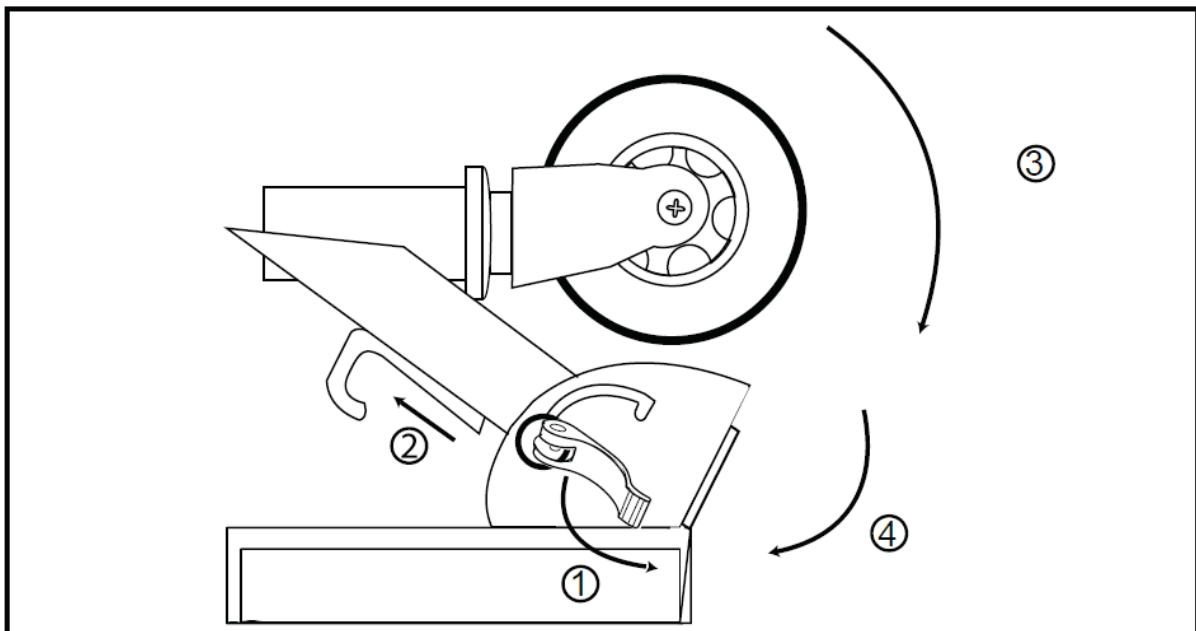

- Release the folding latch (Part 1) away from the scooter
- Pull the plastic latch upwards (Part 2)
- Pull the stem upwards until it clicks into place (Part 3)
- Ensure that once it is in place that the folding latch is closed tightly to secure the upright position of the scooter (Refer to Part 4)

## STEP 2: HANDLE BAR PLACEMENT

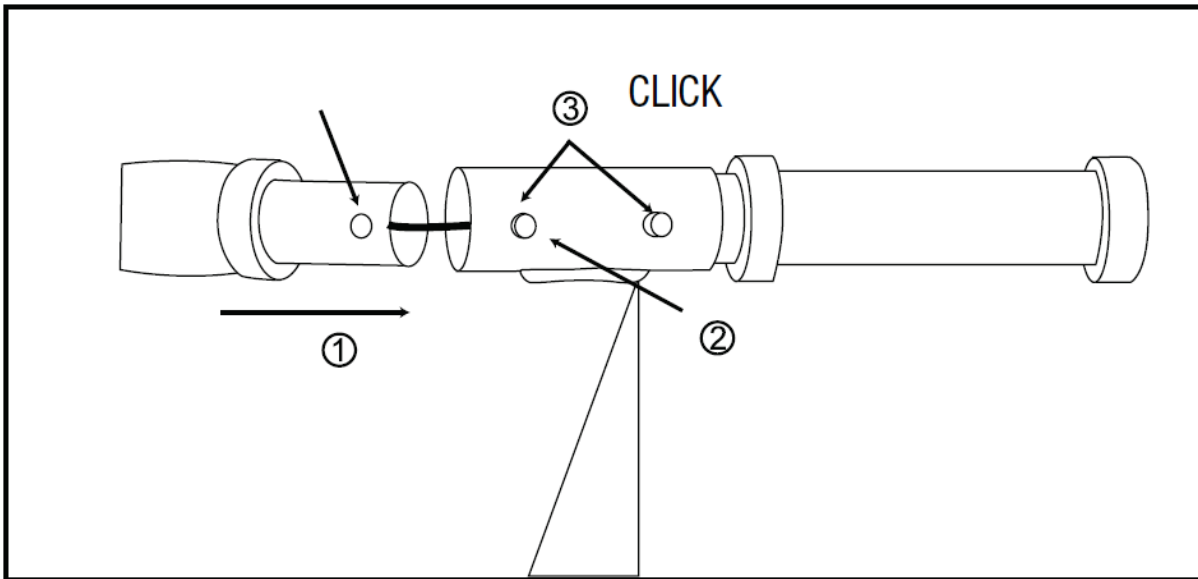

**WARNING:** Failure to properly lock the push pins can result in handlebar movement and a loss of control when using the product.

- Align the push pin and push pin hole (Part 1 & 2)
- Insert the handle bar end into the steering tube until the push pin locks into the hole securely (Part 3)
- Repeat for the other side

## STEP 3: HANDLE BAR HEIGHT ADJUSTMENT

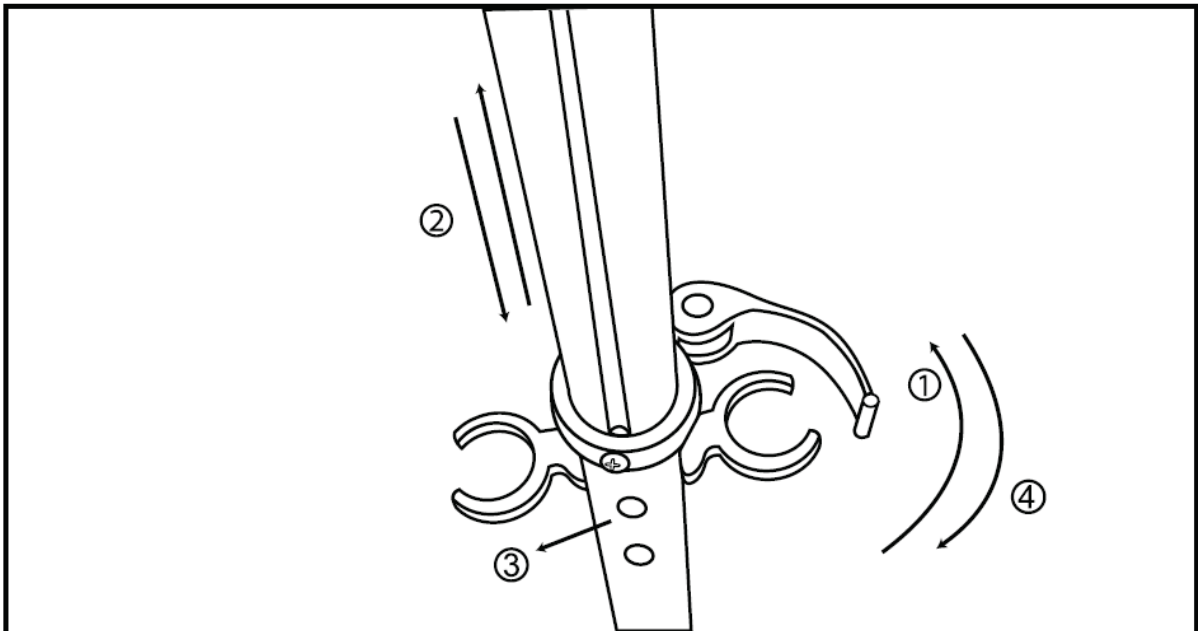

- Open the handlebar clamp by releasing the lever in an outward position (Part 1)
- Extend the handlebar to the desired height (Part 2). When the handlebar extends to the desired height either maximum or minimum height level, make sure the pin is aligned with the pin hole (Part 3). **DO NOT EXCEED THE HEIGHT OF THE TOP PIN HOLE**
- Firmly close the clamp. Push the lever inward to the close position (Part4)

## FOLDING

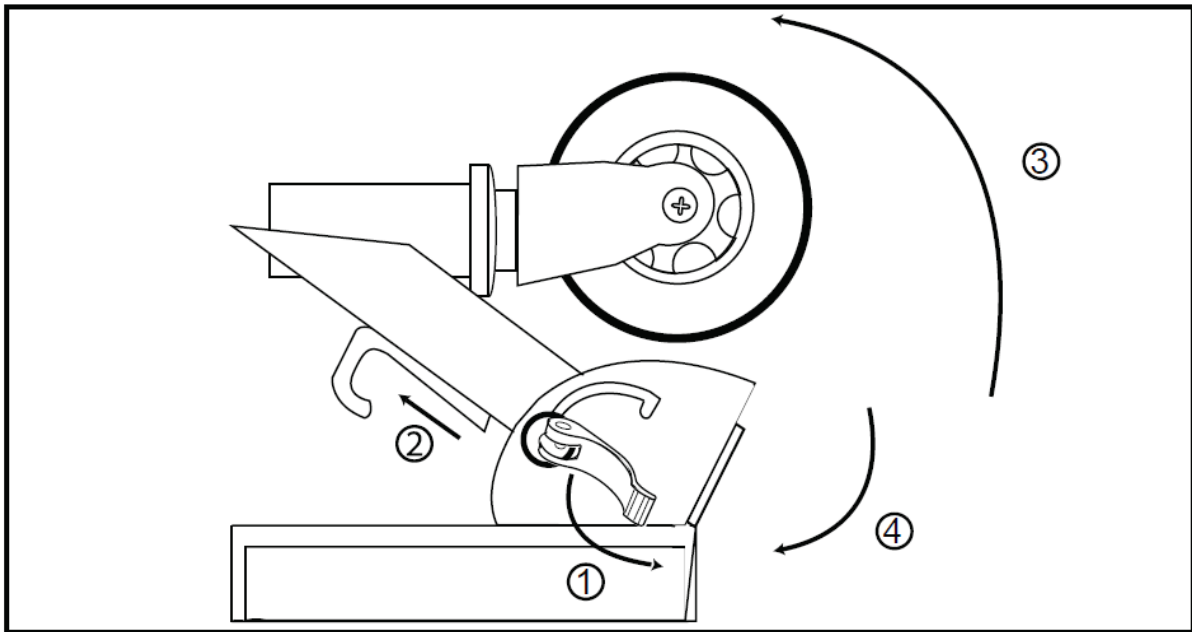

- Release the folding latch (Part 1) away from the scooter
- Pull the plastic latch upwards (Part 2)
- Pull the stem downwards towards the deck of the scooter so it is in a folded position (Part 3)
- Ensure that once it is in place that the folding latch is closed to secure the folded position of the scooter (Part 4)

## TO RELEASE HANDLEBARS:

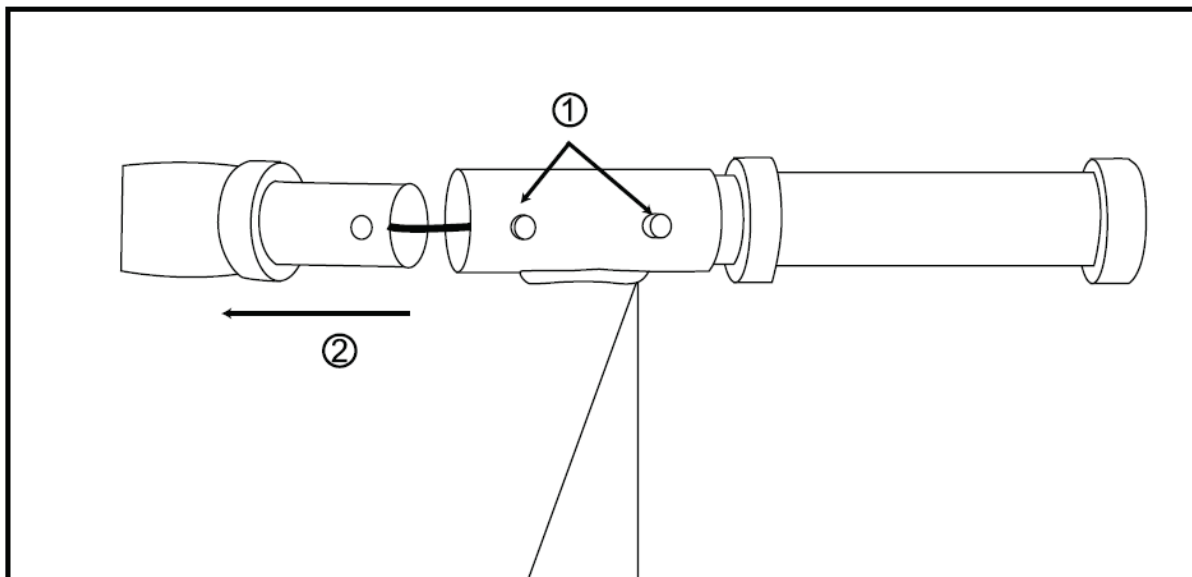

- Push on pin to release the handle bars (Part 1)
- Pull handlebars outwards to detach (Part 2)

TO MINIMIZE THE HANDLEBAR HEIGHT:

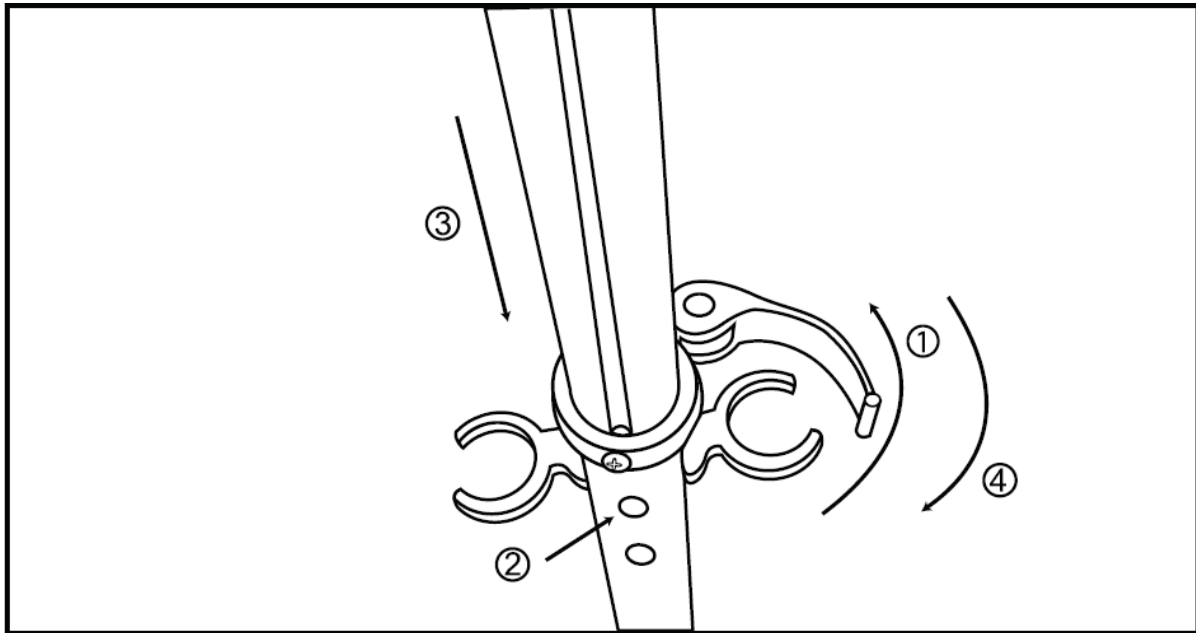

- Open the handlebar clamp by releasing the lever in an outward position (Part 1)
- Push down the handlebar to the minimum height. Make sure the pin is aligned with the lowest pin hole (Part 2 & Part 3)
- Firmly close the clamp. Push the lever inward to the close position (Part 4)
- Store away until next use. Ensure not to leave in outdoor weather conditions

## MAINTENANCE

1. Perform regular checks to make sure all bolts are tightened properly.
2. Do not use chemical cleaners. Wipe the dirt off with a clean dry or wet cloth.
3. To avoid and corrosion, store the product in a well-ventilated place, protected against dust and direct sunlight. This will protect the paint and prevent corrosion of parts.
4. If wheels / bearings do not rotate freely or are damaged, replace them using an Allen key.
5. Do not modify the product in any way not recommended by the manufacturer.

## TERMS AND CONDITIONS OF WARRANTY, WARRANTY CLAIMS

### General Conditions of Warranty and Definition of Terms

All Warranty Conditions stated hereunder determine Warranty Coverage and Warranty Claim Procedure. Conditions of Warranty and Warranty Claims are governed by Act No. 40/1964 Coll. Civil Code, Act No. 513/1991 Coll., Commercial Code, and Act No. 634/1992 Coll., Consumer Protection Act, as amended, also in cases that are not specified by these Warranty rules.

The seller is SEVEN SPORT s.r.o. with its registered office in Borivojova Street 35/878, Prague 13000, Company Registration Number: 26847264, registered in the Trade Register at Regional Court in Prague, Section C, Insert No. 116888.

According to valid legal regulations it depends whether the Buyer is the End Customer or not.

“The Buyer who is the End Customer” or simply the “End Customer” is the legal entity that does not conclude and execute the Contract in order to run or promote his own trade or business activities.

“The Buyer who is not the End Customer” is a Businessman that buys Goods or uses services for the purpose of using the Goods or services for his own business activities. The Buyer conforms to the

General Purchase Agreement and business conditions to the extent specified in the Commercial Code.

These Conditions of Warranty and Warranty Claims are an integral part of every Purchase Agreement made between the Seller and the Buyer. All Warranty Conditions are valid and binding, unless otherwise specified in the Purchase Agreement, in the Amendment to this Contract or in another written agreement.

### **Warranty Conditions**

#### Warranty Period

The Seller provides the Buyer a 24 months Warranty for Goods Quality, unless otherwise specified in the Certificate of Warranty, Invoice, Bill of Delivery or other documents related to the Goods. The legal warranty period provided to the Consumer is not affected.

By the Warranty for Goods Quality, the Seller guarantees that the delivered Goods shall be, for a certain period of time, suitable for regular or contracted use, and that the Goods shall maintain its regular or contracted features.

#### **The Warranty does not cover defects resulting from (if applicable):**

User's fault, i.e. product damage caused by unqualified repair work, improper assembly, insufficient insertion of seat post into frame, insufficient tightening of pedals and cranks

Improper maintenance

Mechanical damages

Regular use (e.g. wearing out of rubber and plastic parts, joints etc.)

Unavoidable event, natural disaster

Adjustments made by unqualified person

Improper maintenance, improper placement, damages caused by low or high temperature, water, inappropriate pressure, shocks, intentional changes in design or construction etc.

### **Warranty Claim Procedure**

The Buyer is obliged to check the Goods delivered by the Seller immediately after taking the responsibility for the Goods and its damages, i.e. immediately after its delivery. The Buyer must check the Goods so that he discovers all the defects that can be discovered by such check.

When making a Warranty Claim the Buyer is obliged, on request of the Seller, to prove the purchase and validity of the claim by the Invoice or Bill of Delivery that includes the product's serial number, or eventually by the documents without the serial number. If the Buyer does not prove the validity of the Warranty Claim by these documents, the Seller has the right to reject the Warranty Claim.

If the Buyer gives notice of a defect that is not covered by the Warranty (e.g. in the case that the Warranty Conditions were not fulfilled or in the case of reporting the defect by mistake etc.), the Seller is eligible to require a compensation for all the costs arising from the repair. The cost shall be calculated according to the valid price list of services and transport costs.

If the Seller finds out (by testing) that the product is not damaged, the Warranty Claim is not accepted. The Seller reserves the right to claim a compensation for costs arising from the false Warranty Claim.

In case the Buyer makes a claim about the Goods that is legally covered by the Warranty provided by the Seller, the Seller shall fix the reported defects by means of repair or by the exchange of the damaged part or product for a new one. Based on the agreement of the Buyer, the Seller has the right to exchange the defected Goods for a fully compatible Goods of the same or better technical characteristics. The Seller is entitled to choose the form of the Warranty Claim Procedures described in this paragraph.

The Seller shall settle the Warranty Claim within 30 days after the delivery of the defective Goods, unless a longer period has been agreed upon. The day when the repaired or exchanged Goods is handed over to the Buyer is considered to be the day of the Warranty Claim settlement. When the Seller is not able to settle the Warranty Claim within the agreed period due to the specific nature of the Goods defect, he and the Buyer shall make an agreement about an alternative solution. In case such



agreement is not made, the Seller is obliged to provide the Buyer with a financial compensation in the form of a refund.



**SEVEN SPORT s.r.o.**

Registered Office: Borivojova 35/878, 130 00 Praha 3, Czech Republic  
Headquarters: Delnicka 957, 749 01 Vitkov, Czech Republic  
Warranty & Service Centre: Cermenska 486, 749 01 Vitkov, Czech Republic  
CRN: 26847264  
VAT ID: CZ26847264  
Phone: +420 556 300 970  
E-mail: eshop@insportline.cz  
reklamace@insportline.cz  
servis@insportline.cz  
Web: www.insportline.cz

---

**SK**

**INSPORTLINÉ s.r.o.**

Headquarters, Warranty & Service centre: Elektrická 6471, 911 01 Trenčín, Slovakia  
CRN: 36311723  
VAT ID: SK2020177082  
Phone: +421(0)326 526 701  
E-mail: objednavky@insportline.sk  
reklamacie@insportline.sk  
servis@insportline.sk  
Web: www.insportline.sk

Date of Sale:

Stamp and Signature of Seller: