

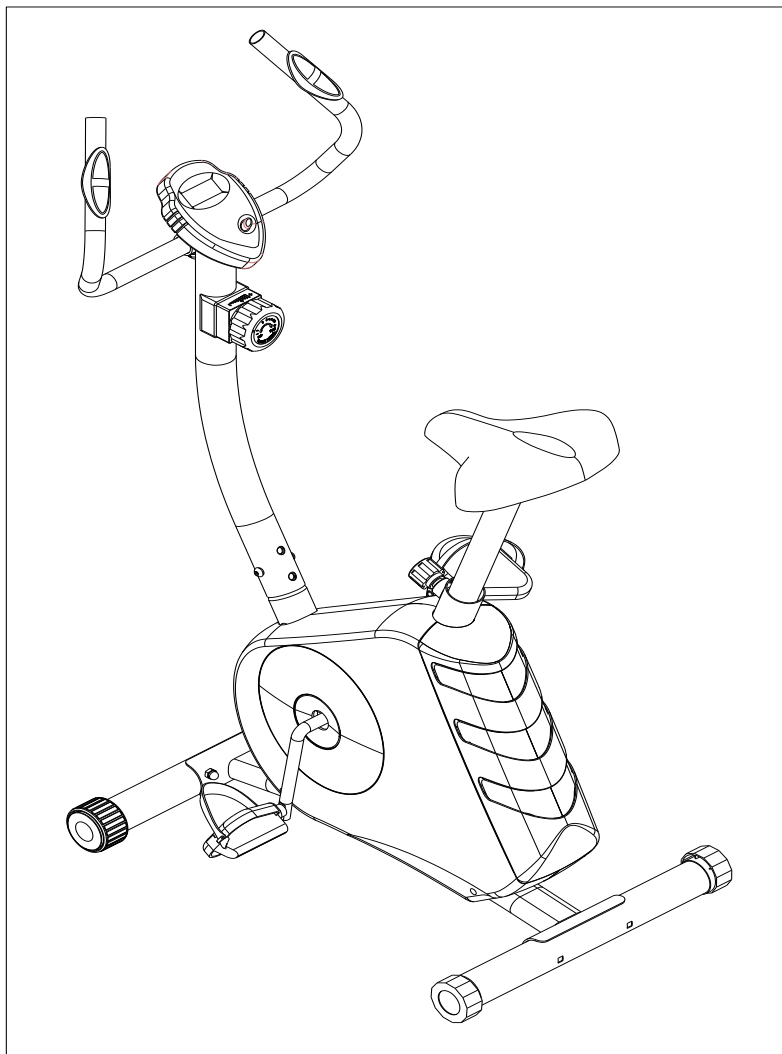

USER MANUAL - EN

IN 7559 Magnetic Upright Bike inSPORTline Kalistic (YK-BA433B)



IMPORTANT!

PLEASE READ THIS MANUAL CAREFULLY BEFORE USING THE BIKE

CONTENTS

IMPORTANT SAFETY INFORMATION 3
EXPLODED VIEW (A) 4
EXPLODED VIEW (B) 5
PARTS LIST 6
ASSEMBLY 9
TERMS AND CONDITIONS OF WARRANTY, WARRANTY CLAIMS..... 13

IMPORTANT SAFETY INFORMATION

We thank you for choosing our product. To guarantee your safety and health, please use this equipment correctly. Please read the information as below carefully before using this equipment.

1. It is important to read this entire manual before assembling and using the equipment. Safe and effective use can only be achieved if the equipment is assembled, maintained and used properly. It is your responsibility to ensure that all users of the equipment are informed of all warnings and precautions.
2. Before starting any exercise program you should consult your doctor to determine if you have any medical or physical conditions that could put your health and safety at risk, or prevent you from using the equipment properly. Your doctor's advice is essential if you are taking medication that affects your heart rate, blood pressure or cholesterol level.
3. Be aware of your body's signals. Incorrect or excessive exercise can damage your health. Stop exercising if you experience any of the following symptoms: pain, tightness in your chest, irregular heartbeat, extreme shortness of breath, lightheadedness, dizziness or feelings of nausea. If you do experience any of these conditions you should consult your doctor before continuing with your exercise program.
4. Keep children and pets away from the equipment. The equipment is designed for adult use only.
5. Use the equipment on a solid, flat level surface with a protective cover for your floor or carpet. To ensure safety, the equipment should have at least 0.5 meters of free space all around it.
6. Before using the equipment, check that the nuts and bolts are securely tightened.
7. The safety of the equipment can only be maintained if it is regularly examined for damage and/or wear and tear.
8. Always use the equipment as indicated. If you find any defective components while assembling or checking the equipment, or if you hear any unusual noises coming from the equipment during use, stop immediately. Do not use the equipment until the problem has been rectified.
9. Computer has many function display, it will be based on different level of different people. Warm reminded here, it could only give you some reference.
10. Wear suitable clothing while using the equipment. Avoid wearing loose clothing that may get caught in the equipment or that may restrict or prevent movement.
11. The equipment is suitable only in indoor and household.
12. Maximum weight of user: 110kg.
13. Class - HC (according to EN ISO 20957) for home use.
14. Care must be taken when lifting or moving the equipment to avoid causing unnecessary damage.
15. Please keep this manual and installation tools.
16. This product can't be used as medical equipment.

EXPLODED VIEW (A)

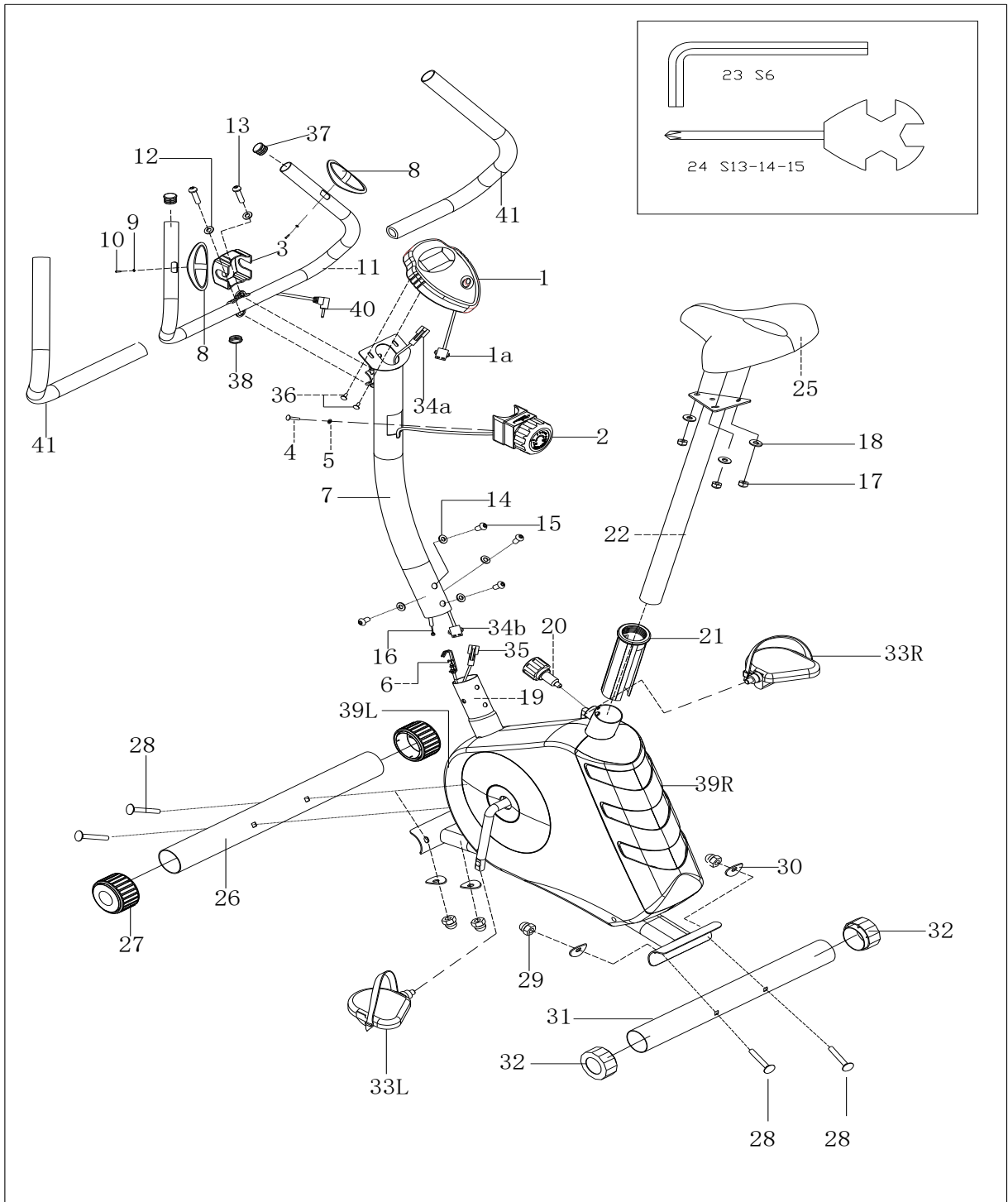

EXPLODED VIEW (B)

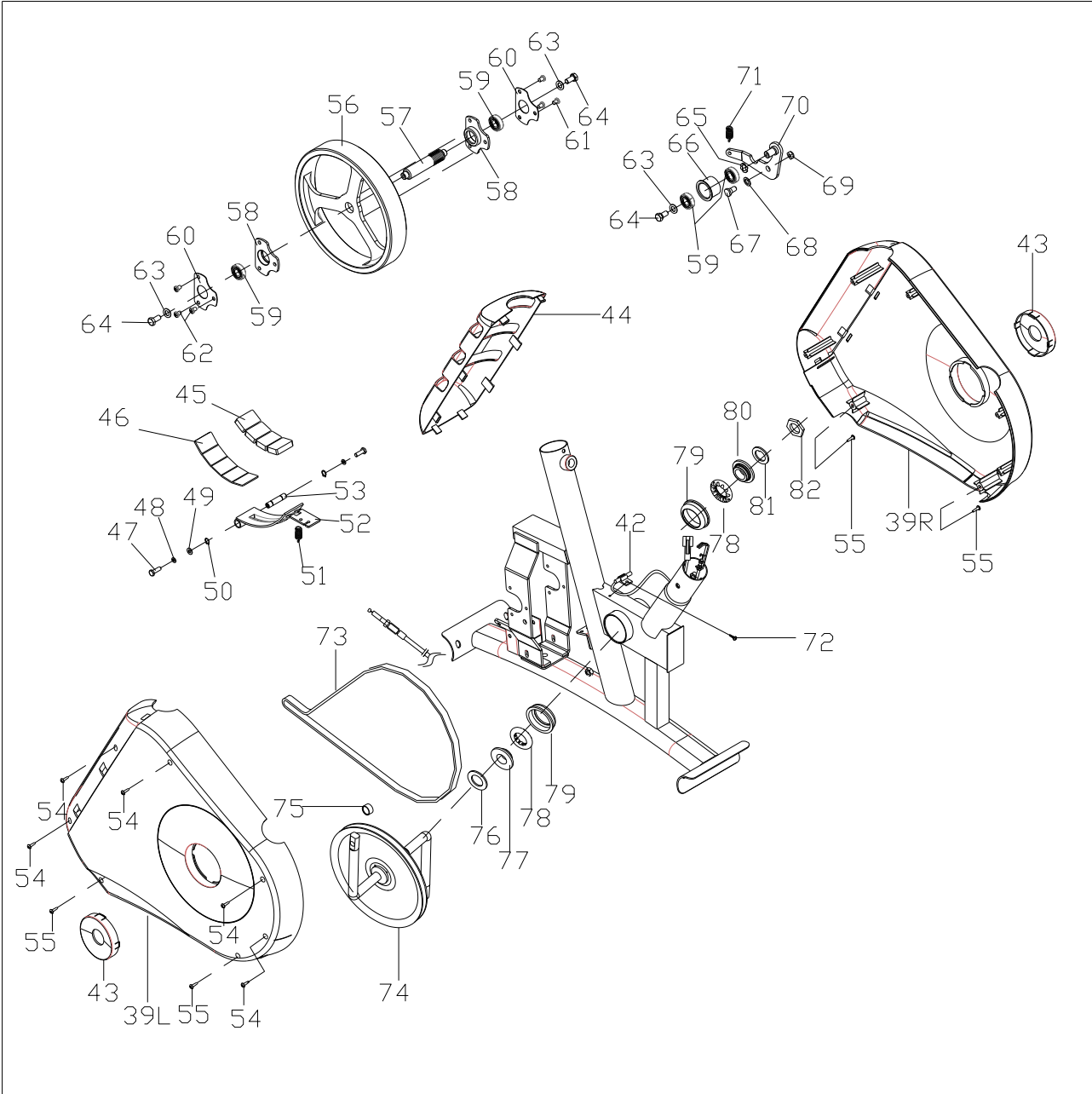

PARTS LIST

NO.	Description	QTY
1	Computer	1
1a	Computer cable	1
2	Tension Control	1
3	Cap 71*58*40	1
4	Bolt M5*16	1
5	Washer d5*Φ10*1	1
6	Tension wire	1
7	Force tube join	1
8	Handle pulse Φ25	2
9	Washer d6*Φ12*1	2
10	Bolt ST4.0*19	2
11	Handlebar join	1
12	Spacer d8	2
13	Bolt M8*30*S6	2
14	Washer d8*Φ20*2*R30	4
15	Bolt M8*16*S6	4
16	Tension upside wire	1
17	Nylon nut M8*H7.5*S13	3
18	Washer d8*Φ16*1.5	3
19	Main frame join	1
20	Knob M16*1.5*22*Φ37	1
21	BushingΦ50*Φ38*164*8	1
22	Seat post join	1
23	Spanner S6	1
24	Spanner S13-14-15	1
25	Saddle	1
26	Front bottom tube	1
27	End cap Φ50*Φ67*45	2
28	Bolt M8*60*20*H5	4
29	Nut M8*H16*S13	4
30	Washer d8*Φ20*2*R30	4
31	Back bottom tube	1
32	End capΦ50*45.5*64.5	2
33 L/R	Pedal HD-16C	1set
34a	Inductor cable	1

34b	Trunk wire	1
35	Sensor Wire	1
36	Bolt M5*10	2
37	End cap $\Phi 25*16$	2
38	End cap $\Phi 12*11*\Phi 3$	1
39L/R	Chain cover	2
40	Wire	1
41	Foam grip $\Phi 25*5*470$	2
42	Inductor	1
43	Crank cover	2
44	Rear cover of chain cover	1
45	Square magnet $40*25*10$	4
46	Magnet location grid	1
47	Bolt M6*16	2
48	Spacer d6	2
49	Washer $d6*\Phi 12*1.2$	2
50	Washer d12	2
51	Tension spring $\Phi 1.5$	1
52	Magnetic board join	1
53	Magnetic board axle	1
54	Bolt ST4.2*19	5
55	Bolt ST4.2*16	4
56	Fly wheel 2KG	1
57	Flywheel axle $\Phi 20*103$	1
58	Bearing seat	2
59	Bearing 6001-2RS	4
60	Fixed set t1.5	2
61	Bolt M6*8	1
62	Bolt M6*10	5
63	Washer $d6*\Phi 16*1.5$	3
64	Bolt M6*10	3
65	Washer $d12*\Phi 15.5*0.3$	1
66	Idle wheel $\Phi 39*24$	1
67	Bolt M8*12*S12	1
68	Washer $d12*\Phi 15*0.5$	1
69	Nylon nut M8	1
70	Idle wheel join	1
71	Tension spring $\Phi 2$	1

72	Bolt	1
73	Belt	1
74	Crank join	1
75	Round magnet Φ 15*7	1
76	Washer	1
77	Nut1	1
78	Rolling ball	2
79	Nine bowl	2
80	Nut 2	1
81	Washer	1
82	Nut	1

ASSEMBLY

STEP 1:

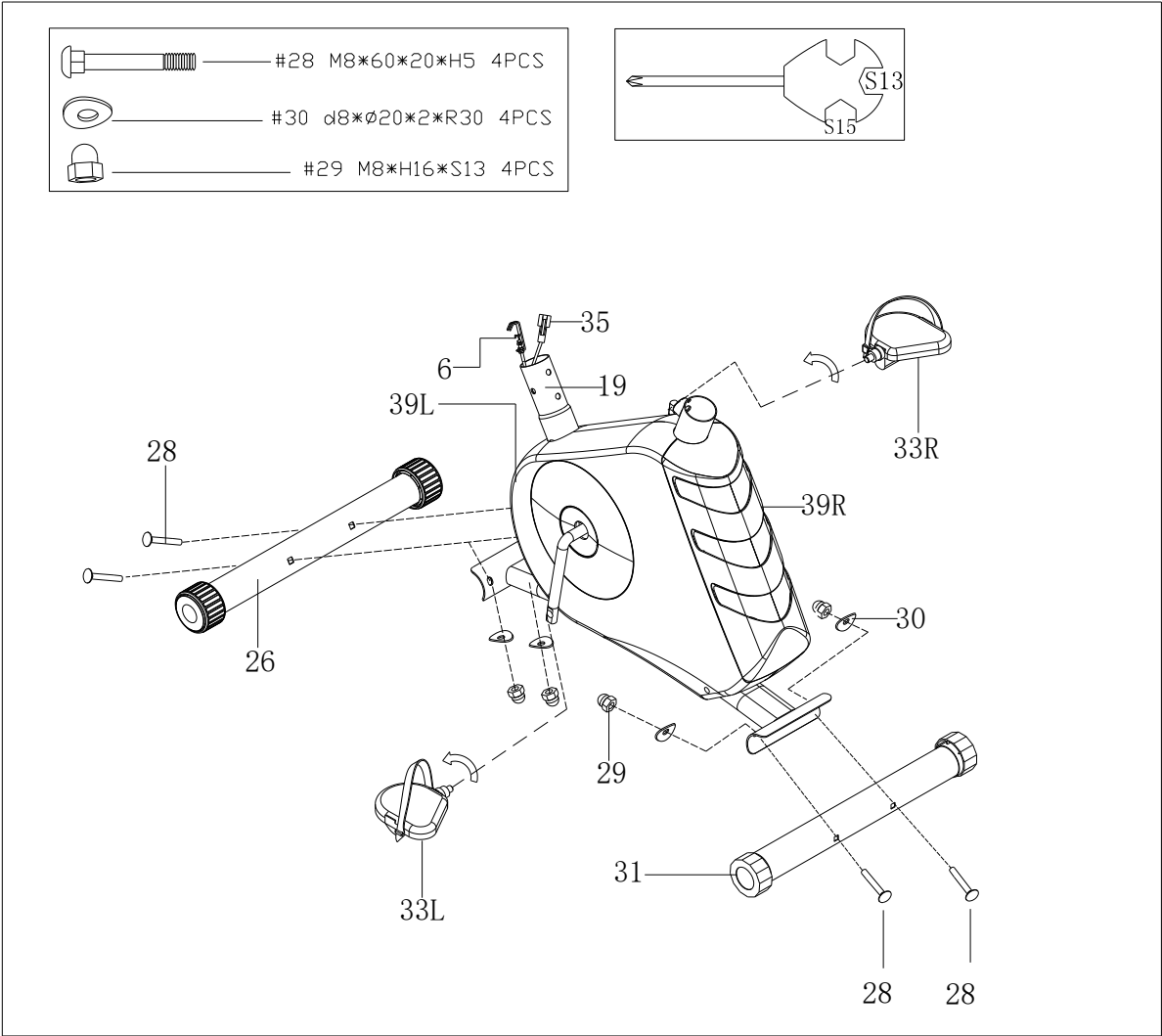

Attach front bottom tube (26), back bottom tube (31) to main frame join (19) with bolt (28), washer (30) and nut (29).

Lock pedal (33L/R) to crank of main frame join (19).

STEP 2:

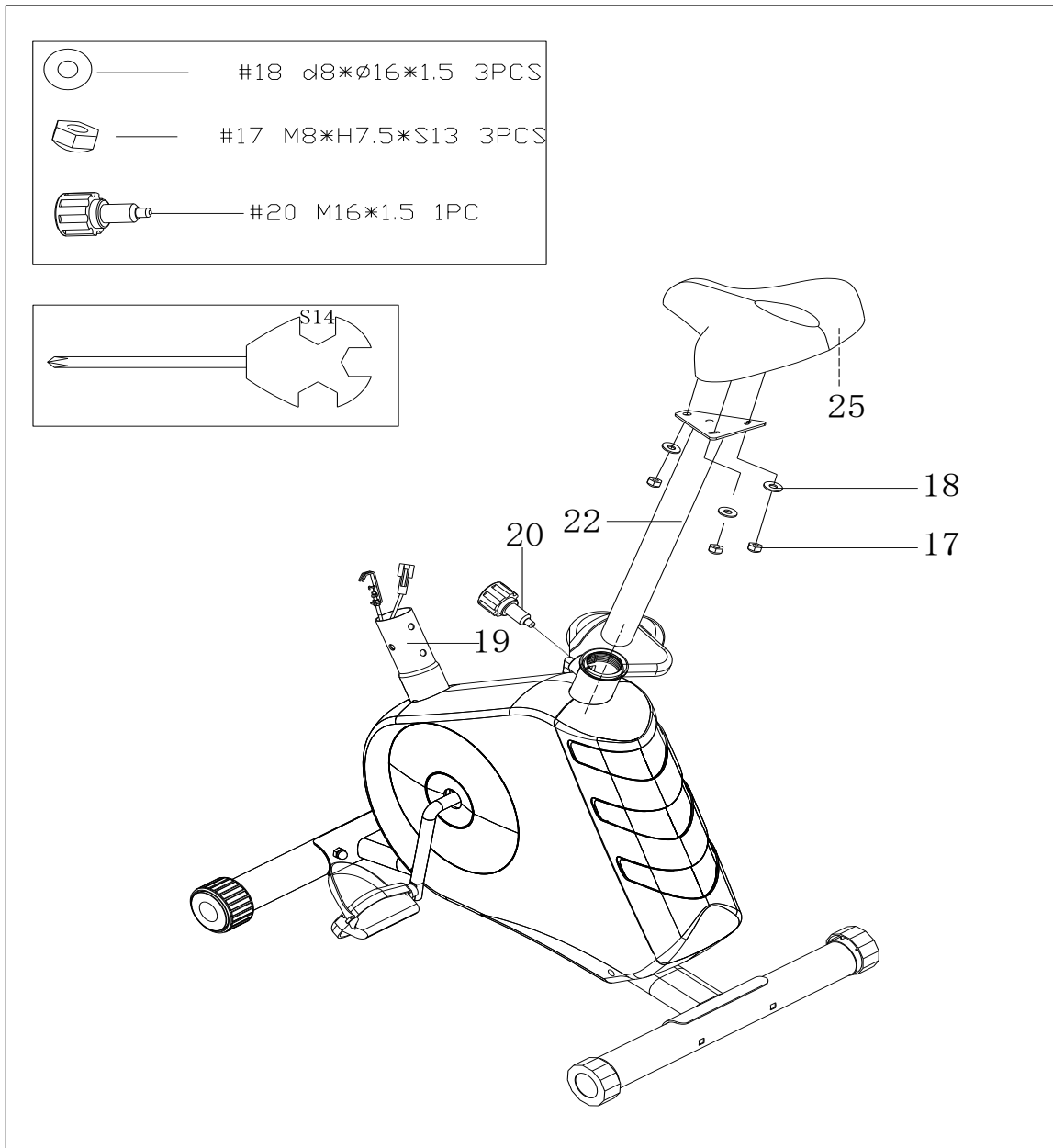

Secure the saddle (25) to the Seat post join (22) with the washer (18) and nylon nut (17)

Insert the Seat post join (22) to the main frame (19), then tighten it after adjusting it to the suitable position.

STEP 3:

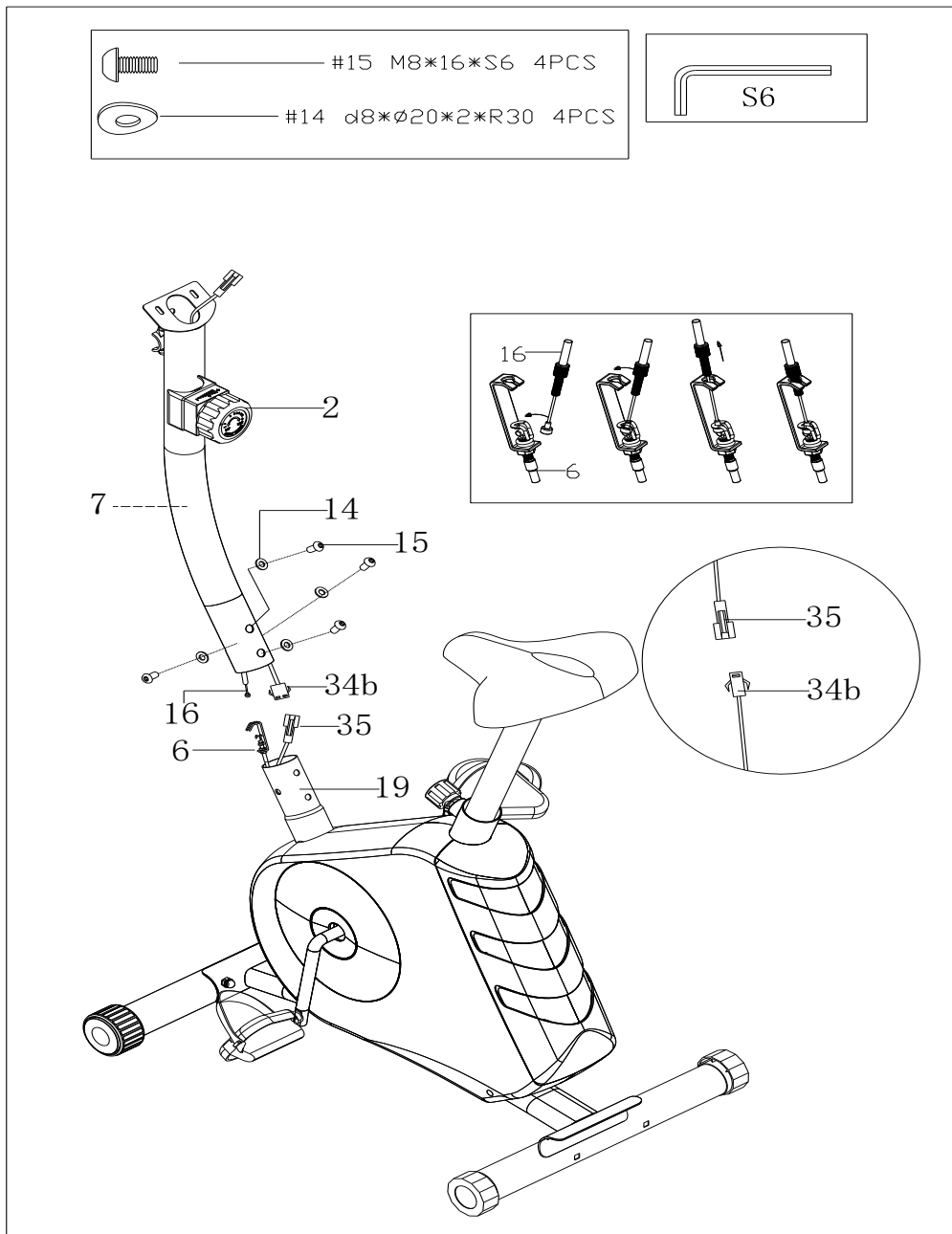

Connect sensor wire (35) with Trunk wire (34b).

Connect tension wire (16) with tension wire (6).

Lock force tube join (7) to main frame join (19) with bolt (15) and washer (14).

STEP 4:

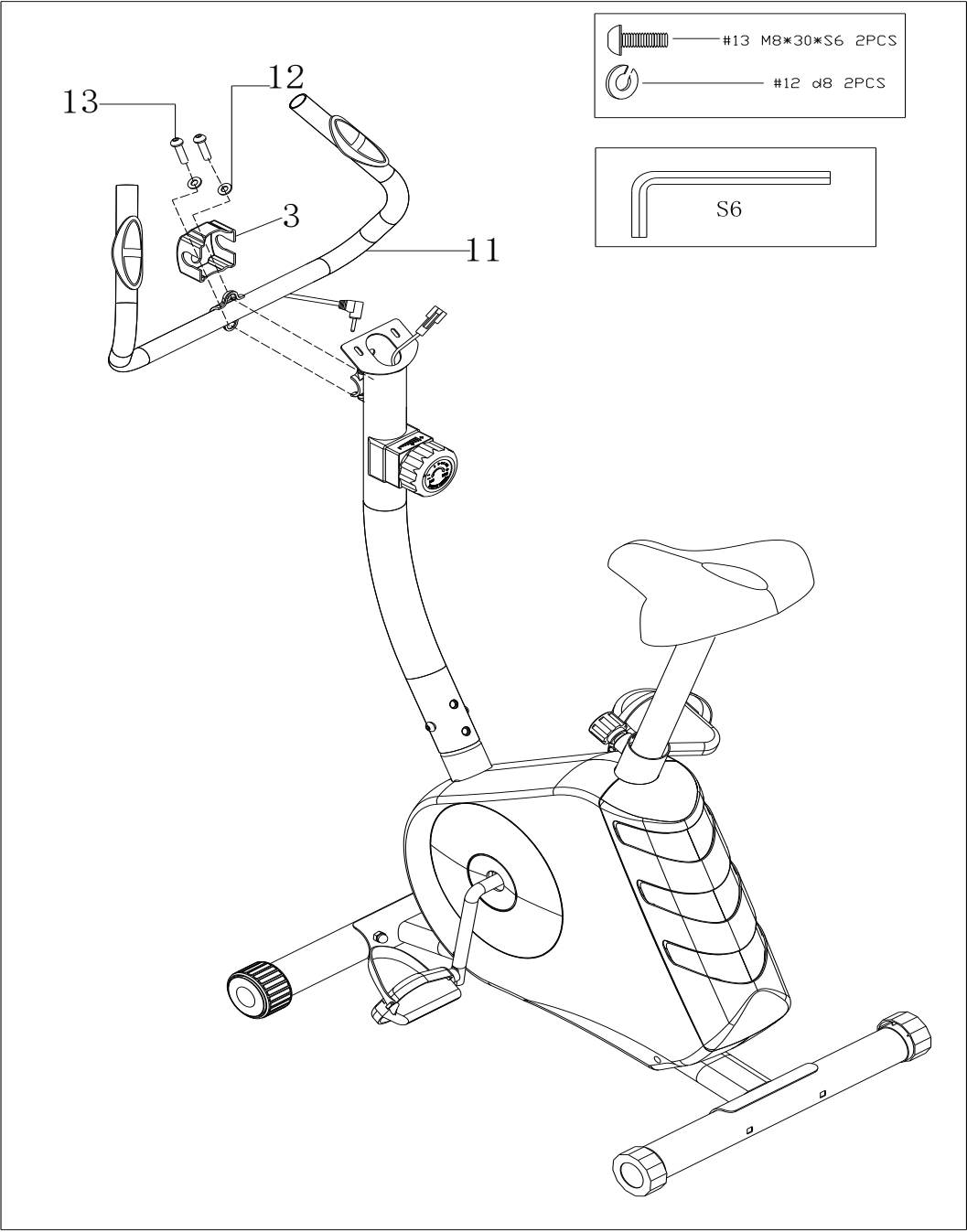

Fit handlebar join (11) into the cap of main frame tube join, lock with bolt (13) and spacer (12).
Lock cap (3) into handlebar.

STEP 5:

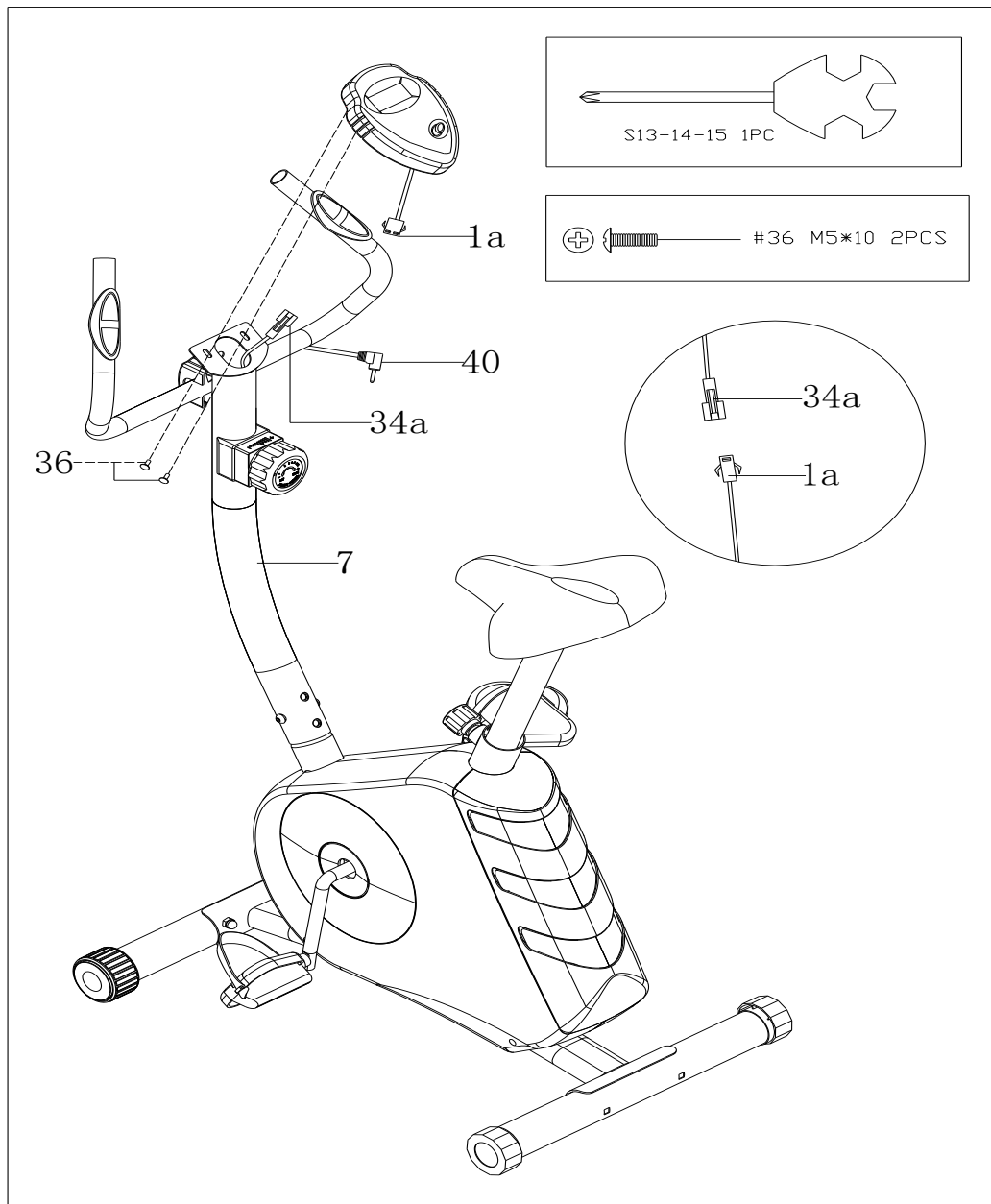

Connect computer wire (1a) with inductor wire (34a). Lock computer (1) into computer board of force tube join (7) with bolt (36), insert wire (40) into the hold of computer's back.

Installation is completed.

TERMS AND CONDITIONS OF WARRANTY, WARRANTY CLAIMS

General Conditions of Warranty and Definition of Terms

All Warranty Conditions stated hereunder determine Warranty Coverage and Warranty Claim Procedure. Conditions of Warranty and Warranty Claims are governed by Act No. 40/1964 Coll. Civil Code, Act No. 513/1991 Coll., Commercial Code, and Act No. 634/1992 Coll., Consumer Protection Act, as amended, also in cases that are not specified by these Warranty rules.

The seller is SEVEN SPORT s.r.o. with its registered office in Borivojova Street 35/878, Prague 13000, Company Registration Number: 26847264, registered in the Trade Register at Regional Court in Prague, Section C, Insert No. 116888.

According to valid legal regulations it depends whether the Buyer is the End Customer or not.

“The Buyer who is the End Customer” or simply the “End Customer” is the legal entity that does not conclude and execute the Contract in order to run or promote his own trade or business activities.

“The Buyer who is not the End Customer” is a Businessman that buys Goods or uses services for the purpose of using the Goods or services for his own business activities. The Buyer conforms to the General Purchase Agreement and business conditions to the extent specified in the Commercial Code.

These Conditions of Warranty and Warranty Claims are an integral part of every Purchase Agreement made between the Seller and the Buyer. All Warranty Conditions are valid and binding, unless otherwise specified in the Purchase Agreement, in the Amendment to this Contract or in another written agreement.

Warranty Conditions

Warranty Period

The Seller provides the Buyer a 24 months Warranty for Goods Quality, unless otherwise specified in the Certificate of Warranty, Invoice, Bill of Delivery or other documents related to the Goods. The legal warranty period provided to the Consumer is not affected.

By the Warranty for Goods Quality, the Seller guarantees that the delivered Goods shall be, for a certain period of time, suitable for regular or contracted use, and that the Goods shall maintain its regular or contracted features.

The Warranty does not cover defects resulting from:

User's fault, i.e. product damage caused by unqualified repair work, improper assembly, insufficient insertion of seat post into frame, insufficient tightening of pedals and cranks

Improper maintenance

Mechanical damages

Regular use (e.g. wearing out of rubber and plastic parts, joints etc.)

Unavoidable event, natural disaster

Adjustments made by unqualified person

Improper maintenance, improper placement, damages caused by low or high temperature, water, inappropriate pressure, shocks, intentional changes in design or construction etc.

Warranty Claim Procedure

The Buyer is obliged to check the Goods delivered by the Seller immediately after taking the responsibility for the Goods and its damages, i.e. immediately after its delivery. The Buyer must check the Goods so that he discovers all the defects that can be discovered by such check.

When making a Warranty Claim the Buyer is obliged, on request of the Seller, to prove the purchase and validity of the claim by the Invoice or Bill of Delivery that includes the product's serial number, or eventually by the documents without the serial number. If the Buyer does not prove the validity of the Warranty Claim by these documents, the Seller has the right to reject the Warranty Claim.

If the Buyer gives notice of a defect that is not covered by the Warranty (e.g. in the case that the Warranty Conditions were not fulfilled or in the case of reporting the defect by mistake etc.), the Seller is eligible to require a compensation for all the costs arising from the repair. The cost shall be calculated according to the valid price list of services and transport costs.

If the Seller finds out (by testing) that the product is not damaged, the Warranty Claim is not accepted. The Seller reserves the right to claim a compensation for costs arising from the false Warranty Claim.

In case the Buyer makes a claim about the Goods that is legally covered by the Warranty provided by the Seller, the Seller shall fix the reported defects by means of repair or by the exchange of the damaged part or product for a new one. Based on the agreement of the Buyer, the Seller has the right to exchange the defected Goods for a fully compatible Goods of the same or better technical characteristics. The Seller is entitled to choose the form of the Warranty Claim Procedures described in this paragraph.

The Seller shall settle the Warranty Claim within 30 days after the delivery of the defective Goods, unless a longer period has been agreed upon. The day when the repaired or exchanged Goods is handed over to the Buyer is considered to be the day of the Warranty Claim settlement. When the Seller is not able to settle the Warranty Claim within the agreed period due to the specific nature of the Goods defect, he and the Buyer shall make an agreement about an alternative solution. In case such agreement is not made, the Seller is obliged to provide the Buyer with a financial compensation in the form of a refund.



SEVEN SPORT s.r.o.

Sídlo: Bořivojova 35/878, 130 00, Praha 3, ČR
Centrála: Dělnická 957, 749 01 Vítkov
Reklamace a servis: Čermenská 486, 749 01 Vítkov

IČO: 26847264
DIČ: CZ26847264
Telefon: +420 556 300 970
Mail: eshop@insportline.cz
reklamace@insportline.cz
servis@insportline.cz
Web: www.insportline.cz

SK

inSPORTline s.r.o.

Centrála, reklamácie, servis: Električná 6471, 911 01 Trenčín, SK

IČO: 36311723
DIČ: SK2020177082
Telefón: +421(0)326 526 701
Mail: objednavky@insportline.sk
reklamacie@insportline.sk
servis@insportline.sk
Web: www.insportline.sk

Date of Sale:

Stamp and Signature of Seller: