

# Plyometric Box Set

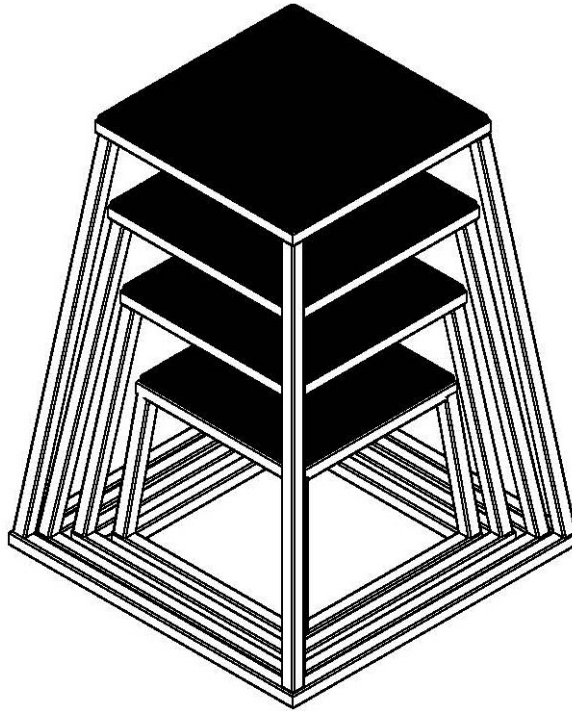

Height	Top	Base
12"	13"×13"	15"×15"
18"	14"×14"	18"×18"
24"	15"×15"	21"×21"
30"	16"×16"	23"×23"

## EXPLODED DIAGRAM

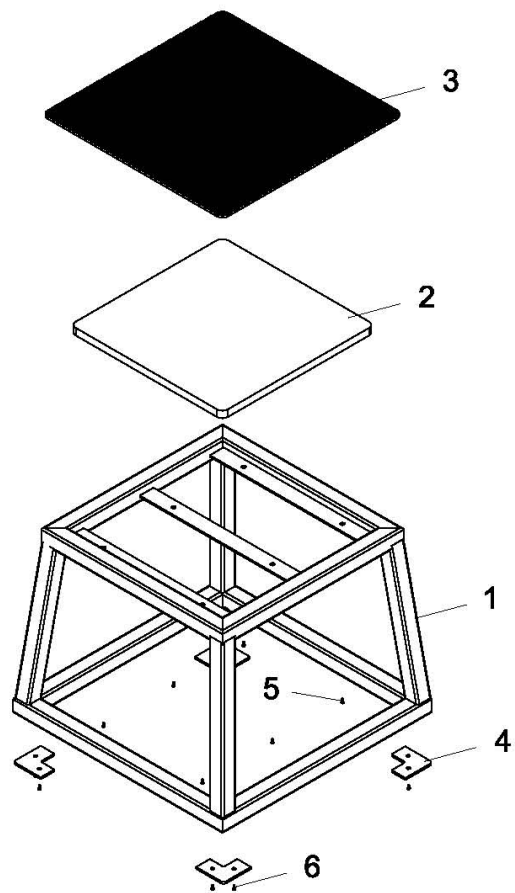

NUMBER	DESCRIPTION	QUANTITY
1	SOLID STEEL CONSTRUCTION	1
2	BOARD	1
3	SOLID RUBBER MAT COVERING	1
4	NON-SLIP PAD	4
5	WOOD SCREW	6
6	SELF DRILLING TAPPING SCREW	8

# Plyo Boxes Exercises

## LATERAL STEP-UP



**Plyo Boxes:** 12 inch

**Start:** Standing to the side of the box, place the foot closest to the box on top of it.

**Action:** Use the leg on the box to raise the body until the leg is extended, then lower to starting position. Don't push off the foot on the ground; use the bent leg to do all the work. Perform exercise using both legs.

## ALTERNATING PUSH-OFF



**Plyo Boxes:** 12 inch

**Start:** Stand on the ground and place one foot on the box, heel close to closest edge.

**Action:** Push off of the foot on the box to gain as much height as possible by extending through the entire leg and foot; land with feet reversed (box foot lands a split second before ground foot). Use a double arm swing for height and balance.

## ALTERNATING PUSH-OFF



**Plyo Boxes:** 12 inch, 18 inch, or 24 inch

**Start:** Stand to one side of the box with the left foot raised onto the middle of box.

**Action:** Using a double arm swing, jump up and over to the other side of the box, landing with the right foot on top of the box and the left foot on the floor. This drill should be done in a continuous motion, shuffling back and forth across top of plyo box.

## SQUAT DEPTH JUMP



**Plyo Boxes:** One or two boxes 12 inch, 18 inch, or 24 inch

**Start:** Stand on a box in a quarter-to-half-squat, toes close to the edge.

**Action:** Step off the box and land in a 90-degree squat position. Explode up out of the squat and land solidly in a squat. For added difficulty, land on a second plyo box of equal height after doing the jump.

## DEPTH JUMP TO RIM JUMP



**Plyo Boxes:** One or two boxes 12 inch, 18 inch, or 24 inch

**Start:** Stand on a box, toes close to the edge

**Action:** Step off the box and land on both feet. Immediately jump up, reaching with one hand toward the marker, and then do repeated jumps, alternating hands and trying to reach the object each time. Time on the ground should be very short, with each jump being as high as the one before. Perform three to five rim jumps after each depth jump.

## DEPTH JUMP WITH 360-Degree TURN



**Plyo Boxes:** 12 inch, 18 inch, or 24 inch

**Start:** Stand to one side of the box with the left foot raised onto middle of the box.

**Action:** Step off the box and land on both feet. Immediately jump up and do a 360-degree turn in the air, landing again on both feet. For added difficulty, land on a second box after doing the turn. This is an advanced drill - it should not be performed by beginners.