

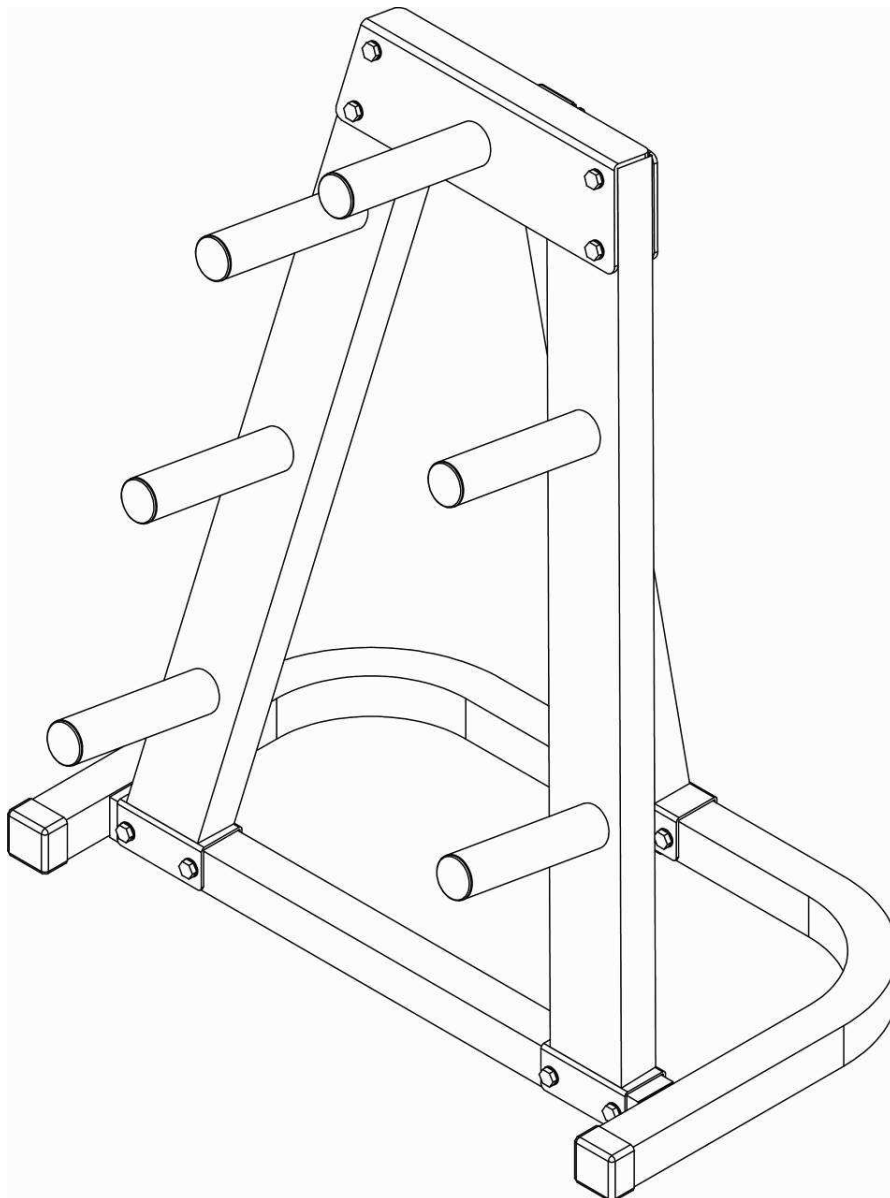

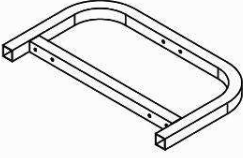

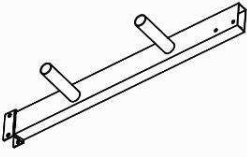

**USER MANUAL - EN**  
**IN 7184 Plate rack inSPORTline PR5010**

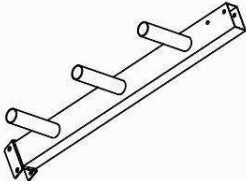
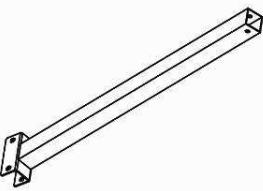
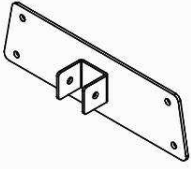
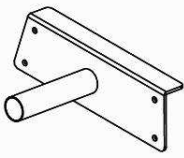
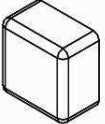
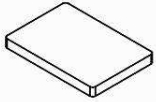

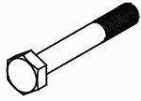
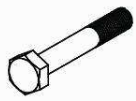
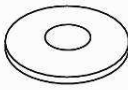
## PARTS LIST

<p><b>1</b></p>  <p>Base Frame 1PC</p>	<p><b>2</b></p>  <p>Left Main Frame 1PC</p>	<p><b>3</b></p>  <p>Right Main Frame 1PC</p>
<p><b>4</b></p>  <p>Support Frame 1PC</p>	<p><b>5</b></p>  <p>Connection Plate 1PC</p>	<p><b>6</b></p>  <p>Weight Plate Holder 1PC</p>
<p><b>7</b></p>  <p>50mm Square End Cap 2PCS</p>	<p><b>8</b></p>  <p>Rubber Sticker 1PC</p>	<p><b>9</b></p>  <p>50mm Square Plug 1PC</p>
<p><b>10</b></p>  <p>48mm Round Plug 6PCS</p>	<p><b>11</b></p>  <p>M10×75mm Hex Bolt 5PCS</p>	<p><b>12</b></p>  <p>M10×70mm Hex Bolt 6PCS</p>
<p><b>13</b></p>  <p>M10 Washer 22PCS</p>	<p><b>14</b></p>  <p>M10 Nylon Nut 11PCS</p>	

## ASSEMBLY INSTRUCTIONS

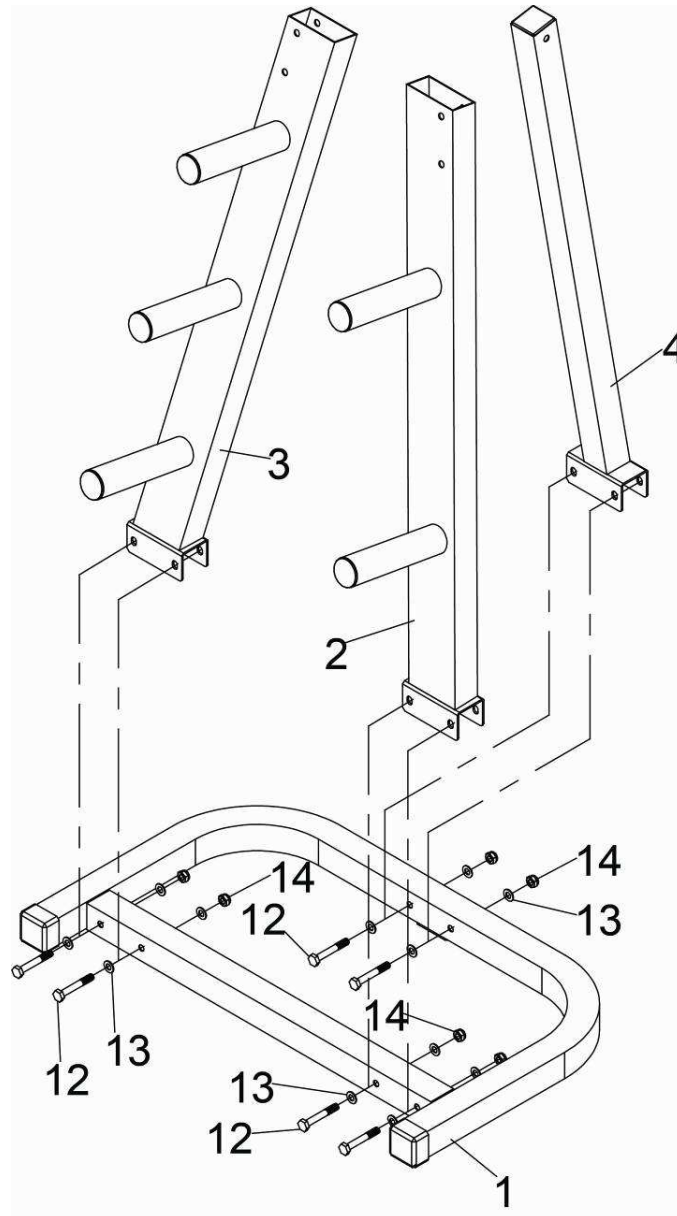

### STEP 1:

1. Attach Left Main Frame (2) and Right Main Frame (3) to Base Frame (1), using four M10X70mm Hex Bolts (12), eight M10 Washers (13) and four M10 Nylon Nuts (14).
2. Attach Support Frame (4) to Base Frame (1), using two M10X70mm Hex Bolts (12), four M10 Washers (13) and two M10 Nylon Nuts (14).

## ASSEMBLY INSTRUCTIONS

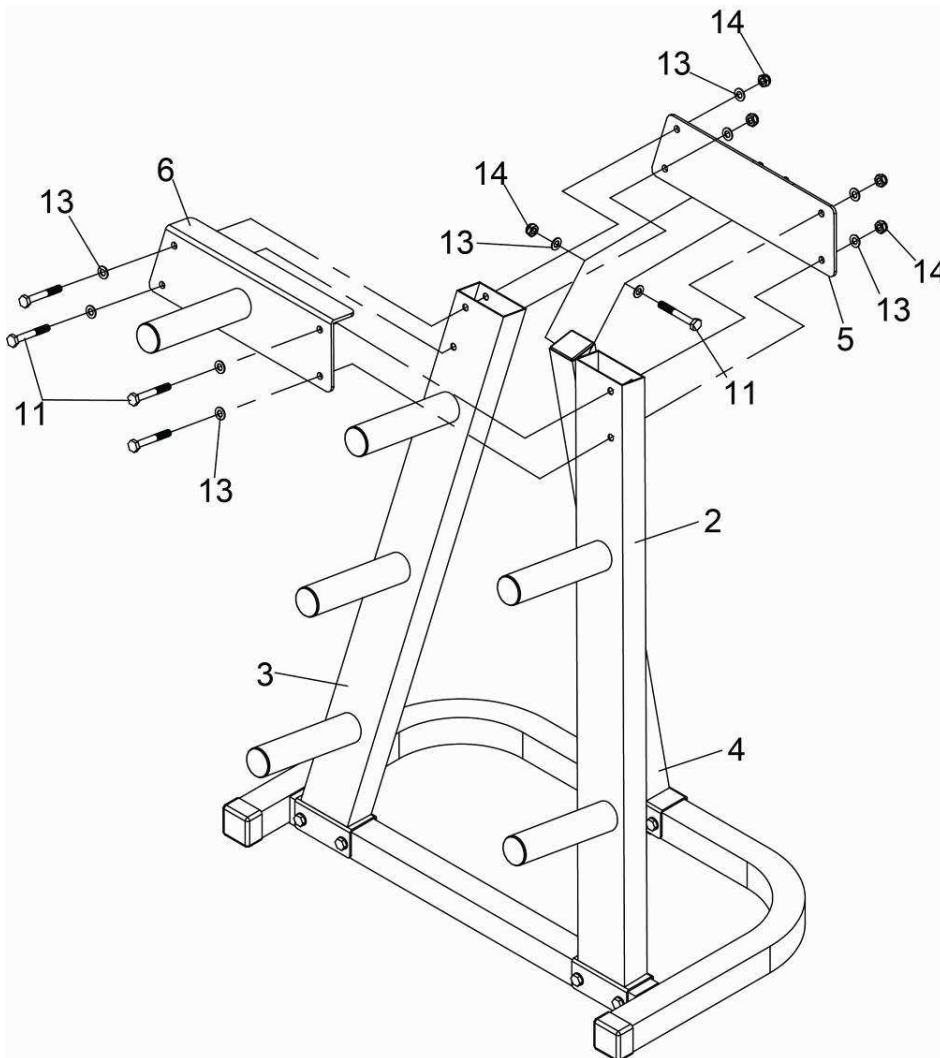

### STEP 2:

1. Attach Connection Plate (5) to Support Frame (4), using one M10X75mm Hex Bolt (11), two M10 Washers (13) and one M10 Nylon Nut (14).
2. Attach Connection Plate (5) and Weight Plate Holder (6) to Left Main Frame (2) and Right Main Frame (3), using four M10X75mm Hex Bolts (11), eight M10 Washers (13) and four Nylon Nuts (14).

# EXPLODED DRAWING

