



USER MANUAL – EN
IN 5500 Flat Bench inSPORTline LKU11010



CONTENTS

SAFETY INSTRUCTIONS..... 3
PARTS LIST 3
ASSEMBLY 4
EXERCISE INSTRUCTIONS 5
ENVIRONMENT PROTECTION 6
TERMS AND CONDITIONS OF WARRANTY, WARRANTY CLAIMS..... 6

SAFETY INSTRUCTIONS

Please read the manual carefully before using the equipment and keep it for future reference.

- Read the manual carefully before assembly and using the device to avoid injury. Instruct other users about security.
- Consult your physician before starting exercise. Your physician can advise you on the optimal load and exercise frequency. Improper use can lead to injury. In particular, consult your condition if you are taking medicines or have an injury.
- If you experience nausea or another anomaly, stop exercising. Do not exercise if you feel: chest pain or tension, irregular heartbeat, shortness of breath, nausea or if you are dizzy. If you observe any health problems, contact your doctor immediately.
- The device may only be used by adults. Do not keep children or pets unattended around the device.
- Place the machine on a flat and solid surface. Use a protection mat to protect the floor. Keep away from other equipment in the room min. 0.6 m.
- Make sure all screws are properly tightened before using the device. Replace damaged parts or worn parts immediately. Proper maintenance will extend the life of the equipment.
- No adjustable part can prohibit movement of user.
- Use the device only in accordance with the manual. Replace worn parts immediately. Do not exercise on damaged equipment.
- Wear suitable clothes during exercise. Avoid too loose clothes that is easy to be stuck. Wear sport shoes.
- Do not use the device outdoors or near water.
- The device is not suitable for therapeutic purposes.
- Do not exercise on the device for about 1 hour before and after a meal.
- Before starting an exercise, do warm up exercise.
- **Bench dimensions:** length 121 cm x width 49.5 cm x height 45 cm
- **Weight limit:** 250 kg (user + weight)

PARTS LIST

NUMBER	SPECIFICATION	DESCRIPTION	QTY
1		Curved beam	1
2		Foot	2
3		Angle iron	2
4		Back pad	1
5		Plastic square foot	4
6		Plain washer	4
7		Plain washer	3
8	M10X25	Hexagon head bolt	4
9	M8X65	Hexagon head bolt	3

ASSEMBLY

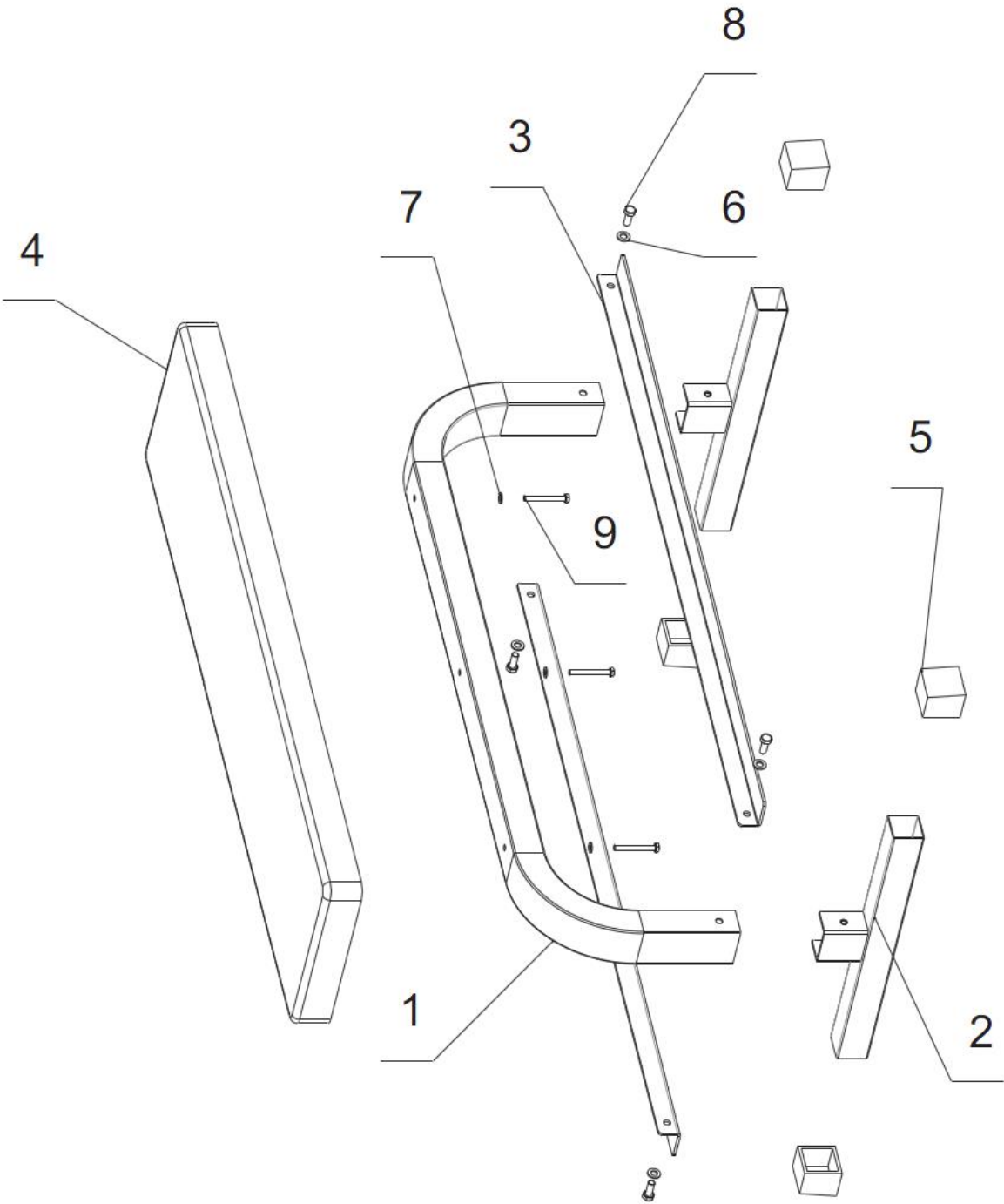

EXERCISE INSTRUCTIONS

Exercise is beneficial to your health, improves physical condition, shapes muscles and, in combination with a calorie-balanced diet, leads to weight loss.

1. WARM UP

This phase serves to improve the blood circulation of the whole body and to warm up the muscles, to reduce the risk of convulsions and muscle injury. We recommend performing the stretching exercises below. When dragging, stay in the end position for approximately 30 seconds, do not make sudden movements and do not vibrate.

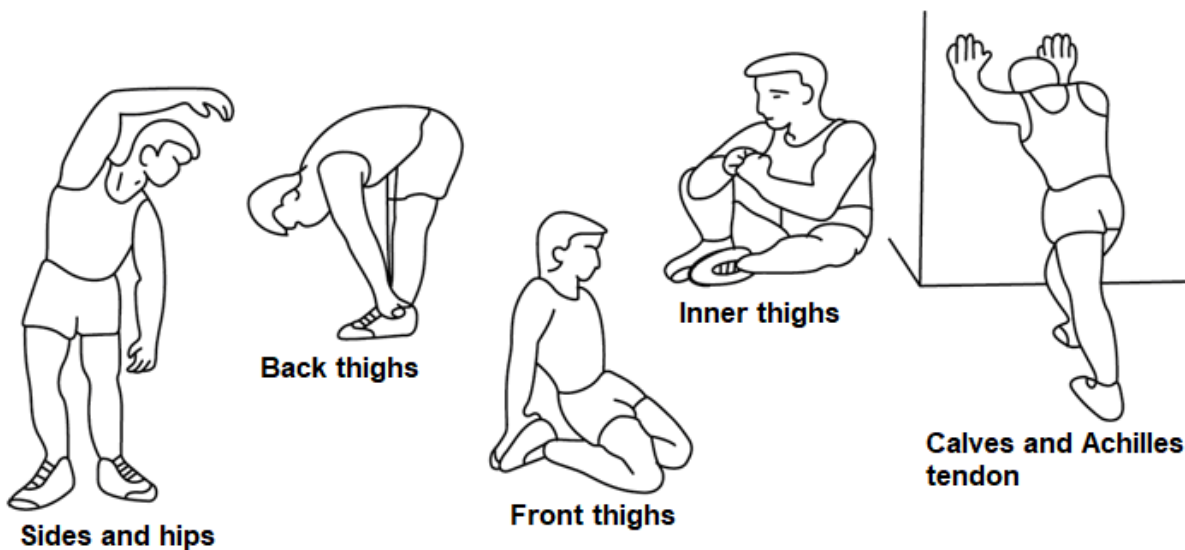

2. EXERCISING

This phase is the most physically demanding part. Regular exercise strengthens the muscles. You can determine the tempo yourself, but it is very important that it is the same throughout the exercise. Heart rate should be within the target zone (see figure below).

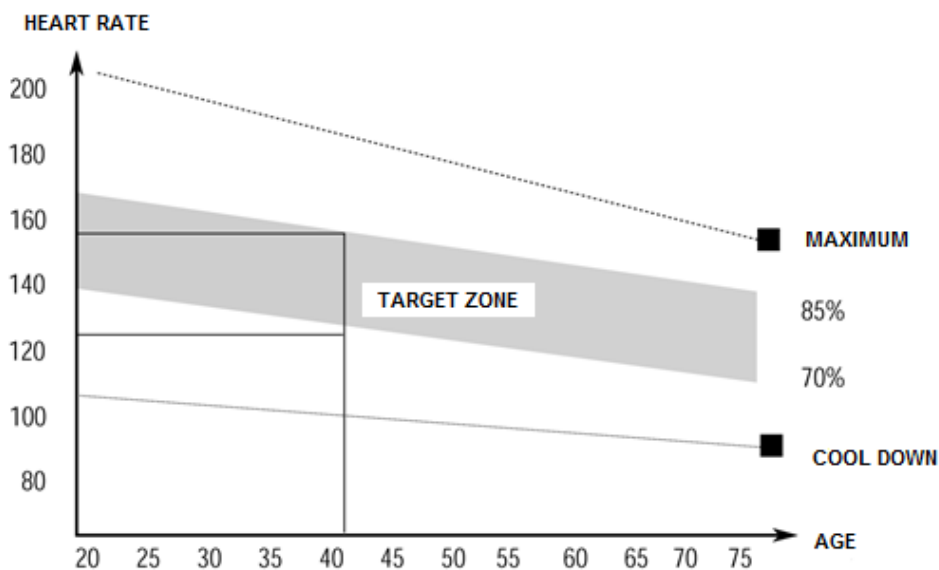

This phase should last at least 12 minutes. Most people exercise for 15-20 minutes.

3. COOLDOWN

This phase serves to soothe the cardiovascular system and relax the muscles. It should take approximately 5 minutes. You can repeat warming up exercises or continue exercising at slower pace. Stretching your muscles after exercise is extremely important - you need to avoid sudden movements and vibrations.

With improved fitness, you can lengthen and increase exercise intensity. Train regularly, at least three times a week.

SHAPING MUSCLES

For muscle shaping, it is important to set a high load. The muscles will be more stressed, which may cause that you will not be able to exercise as long as usual. If you are trying to improve your condition at the same time, you need to adjust your training. Exercise in the usual way during the warm-up and final stages of training but increase the resistance of the device at the end of the exercise. You may need to slow down the speed to keep the heart rate in the target area.

WEIGHT LOSS

The number of calories burned depends on the length and intensity of the exercise. The essence is the same as in fitness exercise, but the goal is different.

MAINTENANCE

1. After exercising, wipe off any sweat to avoid corrosion. Clean the device with a soft cloth and mild detergents. Do not use abrasive cleaners or solvents on plastic parts.
2. In case of increased machine noise, all screws and joints must be checked and tightened properly.
3. The product must be placed in clean, ventilated and dry areas.
4. Do not expose the device to direct sunlight.

ENVIRONMENT PROTECTION

After the product lifespan expired or if the possible repairing is uneconomic, dispose it according to the local laws and environmentally friendly in the nearest scrapyard.

By proper disposal you will protect the environment and natural sources. Moreover, you can help protect human health. If you are not sure in correct disposing, ask local authorities to avoid law violation or sanctions.

TERMS AND CONDITIONS OF WARRANTY, WARRANTY CLAIMS

General Conditions of Warranty and Definition of Terms

All Warranty Conditions stated hereunder determine Warranty Coverage and Warranty Claim Procedure. Conditions of Warranty and Warranty Claims are governed by Act No. 89/2012 Coll. Civil Code, and Act No. 634/1992 Coll., Consumer Protection, as amended, also in cases that are not specified by these Warranty rules.

The seller is SEVEN SPORT s.r.o. with its registered office in Borivojova Street 35/878, Prague 13000, Company Registration Number: 26847264, registered in the Trade Register at Regional Court in Prague, Section C, Insert No. 116888.

According to valid legal regulations it depends whether the Buyer is the End Customer or not.

“The Buyer who is the End Customer” or simply the “End Customer” is the legal entity that does not conclude and execute the Contract in order to run or promote his own trade or business activities.

“The Buyer who is not the End Customer” is a Businessman that buys Goods or uses services for the purpose of using the Goods or services for his own business activities. The Buyer conforms to the General Purchase Agreement and business conditions.

These Conditions of Warranty and Warranty Claims are an integral part of every Purchase Agreement made between the Seller and the Buyer. All Warranty Conditions are valid and binding, unless otherwise specified in the Purchase Agreement, in the Amendment to this Contract or in another written agreement.

Warranty Conditions

Warranty Period

The Seller provides the Buyer a 24 months Warranty for Goods Quality, unless otherwise specified in the Certificate of Warranty, Invoice, Bill of Delivery or other documents related to the Goods. The legal warranty period provided to the Consumer is not affected.

By the Warranty for Goods Quality, the Seller guarantees that the delivered Goods shall be, for a certain period of time, suitable for regular or contracted use, and that the Goods shall maintain its regular or contracted features.

The Warranty does not cover defects resulting from (if applicable):

- User's fault, i.e. product damage caused by unqualified repair work, improper assembly, insufficient insertion of seat post into frame, insufficient tightening of pedals and cranks
- Improper maintenance
- Mechanical damages
- Regular use (e.g. wearing out of rubber and plastic parts, moving mechanisms, joints etc.)
- Unavoidable event, natural disaster
- Adjustments made by unqualified person
- Improper maintenance, improper placement, damages caused by low or high temperature, water, inappropriate pressure, shocks, intentional changes in design or construction etc.

Warranty Claim Procedure

The Buyer is obliged to check the Goods delivered by the Seller immediately after taking the responsibility for the Goods and its damages, i.e. immediately after its delivery. The Buyer must check the Goods so that he discovers all the defects that can be discovered by such check.

When making a Warranty Claim the Buyer is obliged, on request of the Seller, to prove the purchase and validity of the claim by the Invoice or Bill of Delivery that includes the product's serial number, or eventually by the documents without the serial number. If the Buyer does not prove the validity of the Warranty Claim by these documents, the Seller has the right to reject the Warranty Claim.

If the Buyer gives notice of a defect that is not covered by the Warranty (e.g. in the case that the Warranty Conditions were not fulfilled or in the case of reporting the defect by mistake etc.), the Seller is eligible to require a compensation for all the costs arising from the repair. The cost shall be calculated according to the valid price list of services and transport costs.

If the Seller finds out (by testing) that the product is not damaged, the Warranty Claim is not accepted. The Seller reserves the right to claim a compensation for costs arising from the false Warranty Claim.

In case the Buyer makes a claim about the Goods that is legally covered by the Warranty provided by the Seller, the Seller shall fix the reported defects by means of repair or by the exchange of the damaged part or product for a new one. Based on the agreement of the Buyer, the Seller has the right to exchange the defected Goods for a fully compatible Goods of the same or better technical characteristics. The Seller is entitled to choose the form of the Warranty Claim Procedures described in this paragraph.

The Seller shall settle the Warranty Claim within 30 days after the delivery of the defective Goods, unless a longer period has been agreed upon. The day when the repaired or exchanged Goods is handed over to the Buyer is considered to be the day of the Warranty Claim settlement. When the Seller is not able to settle the Warranty Claim within the agreed period due to the specific nature of the Goods defect, he and the Buyer shall make an agreement about an alternative solution. In case such agreement is not made, the Seller is obliged to provide the Buyer with a financial compensation in the form of a refund.



SEVEN SPORT s.r.o.

Registered Office: Borivojova 35/878, 130 00 Praha 3, Czech Republic
Headquarters: Delnicka 957, 749 01 Vitkov, Czech Republic
Warranty & Service Centre: Cermenska 486, 749 01 Vitkov, Czech Republic
CRN: 26847264
VAT ID: CZ26847264
Phone: +420 556 300 970
E-mail: eshop@insportline.cz
reklamace@insportline.cz
servis@insportline.cz
Web: www.insportline.cz

SK

INSPORTLINE s.r.o.

Headquarters, Warranty & Service centre: Elektricna 6471, 911 01 Trencin, Slovakia
CRN: 36311723
VAT ID: SK2020177082
Phone: +421(0)326 526 701
E-mail: objednavky@insportline.sk
reklamacie@insportline.sk
servis@insportline.sk
Web: www.insportline.sk

Date of Sale:

Stamp and Signature of Seller: