

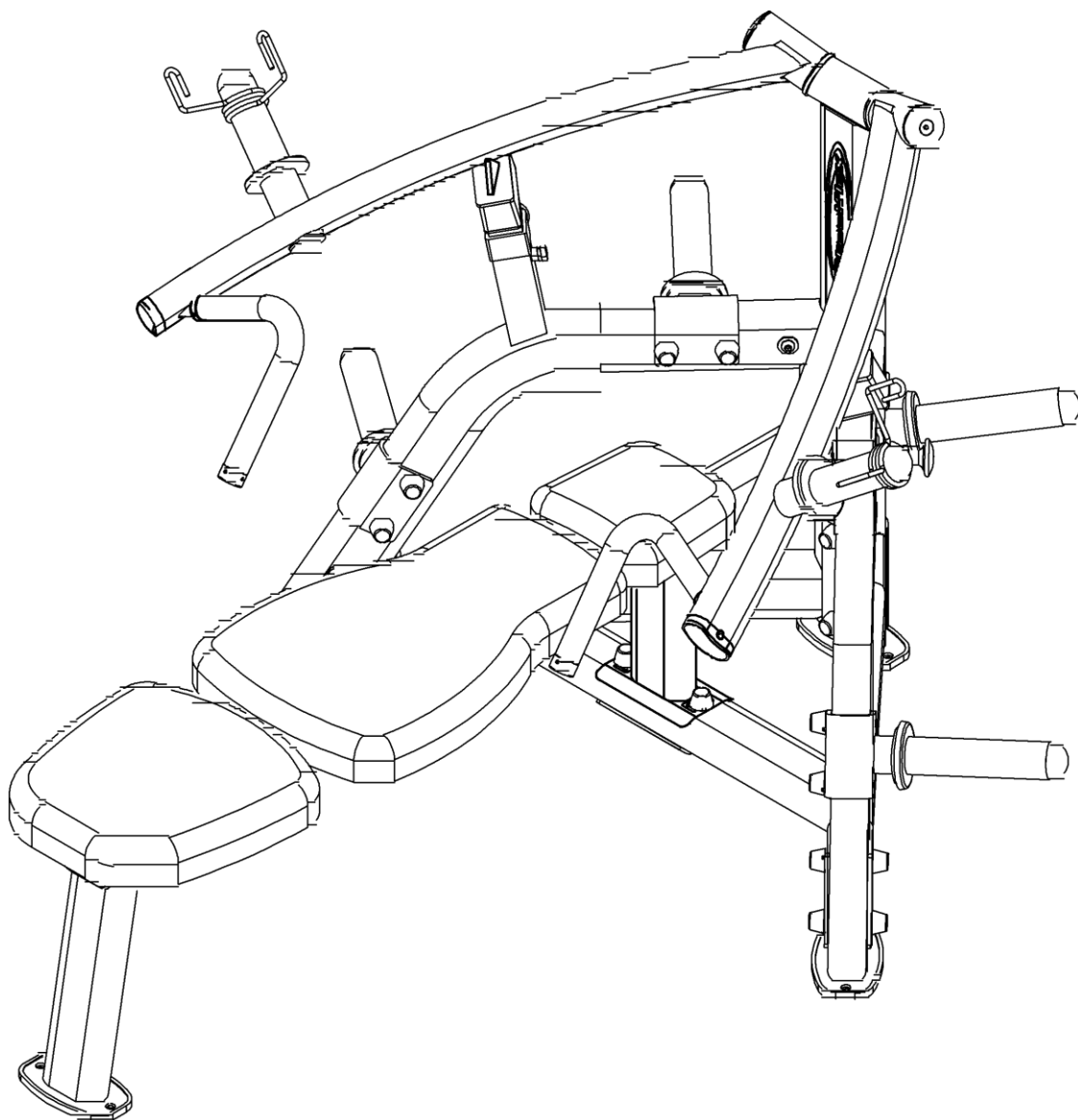

**User manual - EN**  
**IN 5091 Steelflex PLBP – chest press**



# PLBP HARDWARE

(shown in actual size)

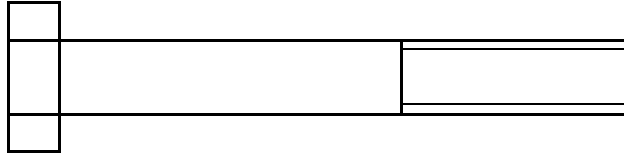
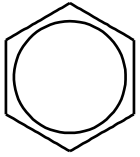

A1. M10x75 HEX HEAD SCREW...10PCS

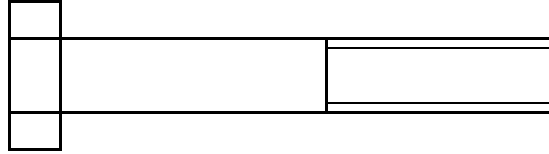
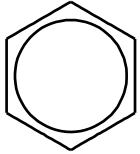

A2. M10x65 HEX HEAD SCREW...8PCS

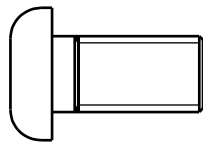
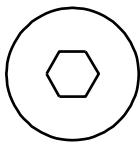

A3. M10x20 ALLEN SCREW(FULL THREAD)...4PCS

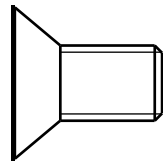
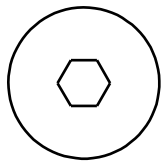

A4. M10x20 TAPER SCREW(FULL THREAD)...2PCS

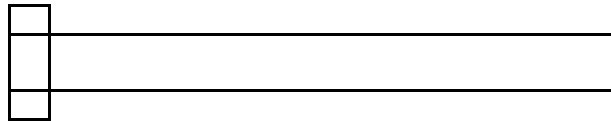
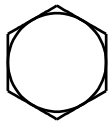

A5. M8x75 HEX HEAD SCREW...1PCS

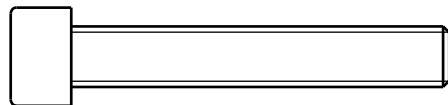
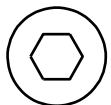

A6. M8x50 SOCKET SCREW(FULL THREAD)...4PCS

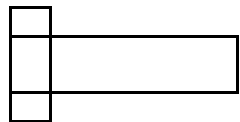
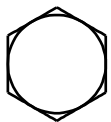

A7. M8x25 HEX HEAD SCREW...8PCS

mm

0 10 20 30 40 50 60 70 80 90 100 110 120 130 140 150

inch

0 1" 2" 3" 4" 5" 6"

(shown in actual size)

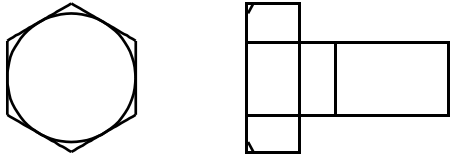

A8. M10x20 HEX HEAD SCREW...2PCS (Pre-installed)



A9. M5x5 GRUB SCREW...8PCS (Pre-installed)

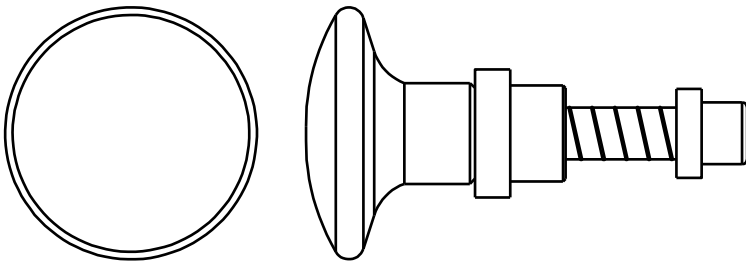

A10. 1/2"x87.5L POP PIN (8250-124G)...2PCS (Pre-installed)

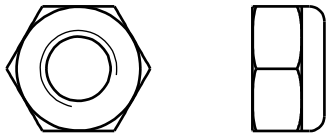

B1. M10 NYLON LOCK NUT...10PCS

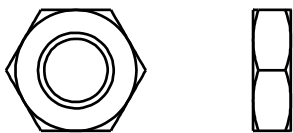

B2. M10 LOCK NUT(5t)...2PCS (Pre-installed)

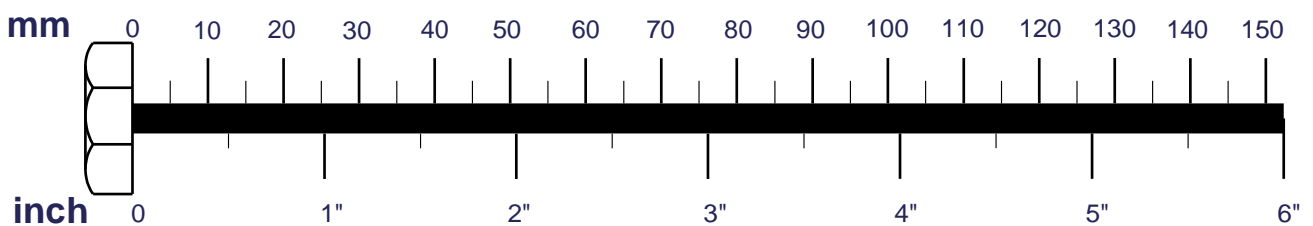

(shown in actual size)

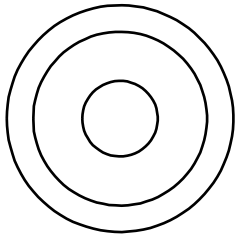

C1. M10 PLATE WASHER(Ø30)...28PCS

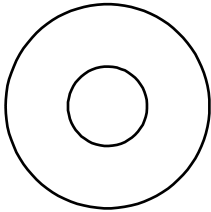

C2. M10 WASHER(Ø27)...4PCS

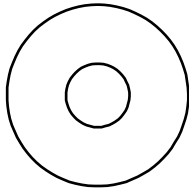

C3. M8 WASHER(Ø24)...9PCS

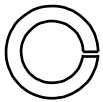

C4. M8 SPRING WASHER...9PCS

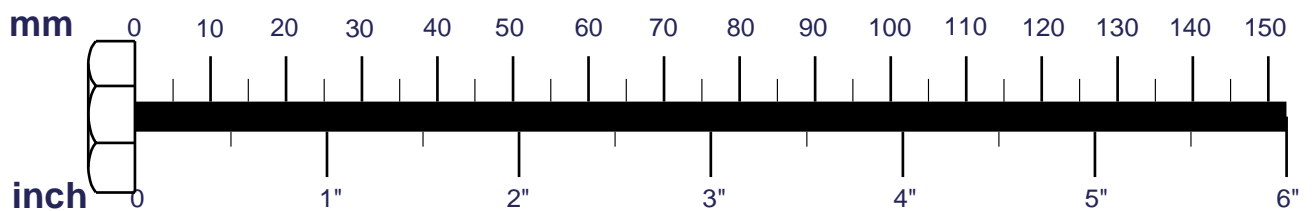

# PLBP PARTS

A [1PCS]

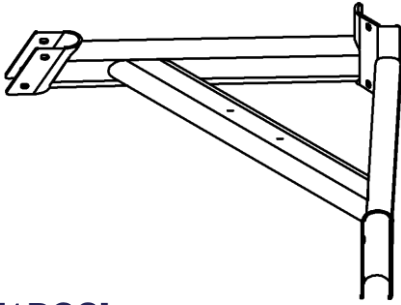

B [1PCS]

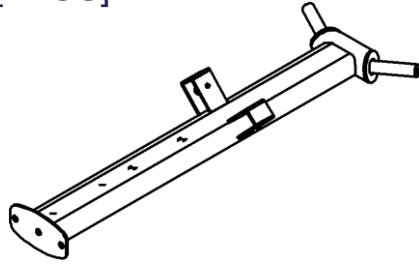

C [1PCS]

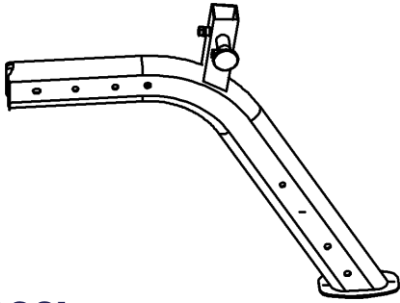

D [1PCS]

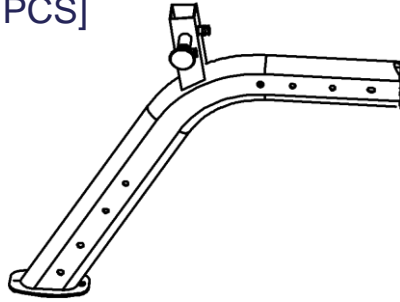

E [1PCS]

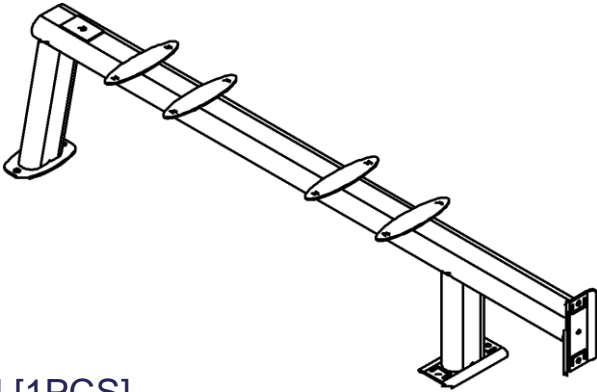

F [2PCS]  
6730003

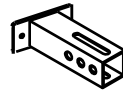

I [1PCS]

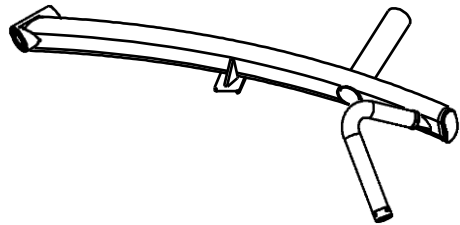

H [1PCS]

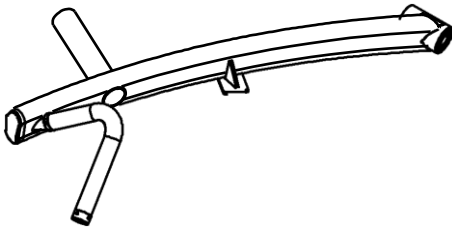

J [4PCS]  
6730001

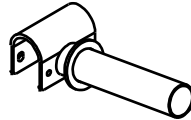

K [3PCS]  
8323188

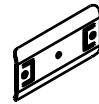

L [1PCS]  
9111071

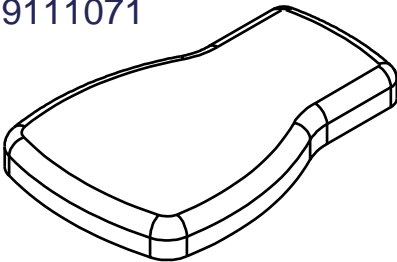

M [1PCS]  
9121075

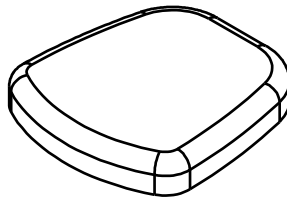

N [1PCS]  
9131025

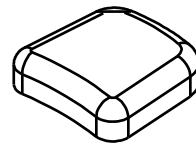

# PLBP PARTS

D1. End Closure (8130-248) .....	[2PCS]
D2. Compression Spring (8840-050) .....	[2PCS]
D3. Ø50 End Cap (9211-020) .....	[2PCS]
D4. Nylon Bushing (9211-030) .....	[2PCS]
D5. Ø50 End Cap (9211-074) .....	[6PCS]
D6. 40x80 End Cap (9211-113) pre-installed.....	[2PCS]
D7. 50x100 END CAP (9211-114) .....	[1PCS]
D8. Rubber Dount (9310-016) .....	[6PCS]
D9. Rubber Insert (9310-076) .....	[4PCS]
D10. Block Rubber (9310-077) .....	[2PCS]
D11. Pinch Cock (OC-06) .....	[2PCS]
D12. Cap Sleeve (9212-026) .....	[28PCS]
D13. Co er Washer (8520-008) .....	[2PCS]
D14. Chrome Collar (8890-061) pre-installed .....	[2PCS]
D15. Bearing (8510-037) pre-installed .....	[4PCS]
D16. Foam Grip (9162-102) pre-installed .....	[2PCS]
D17. End Closure (8130-254)pre-installed.....	[2PCS]

D1



D2

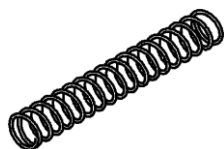

D3



D4

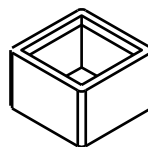

D5



D6



D7



D8

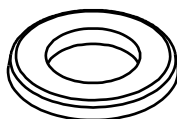

D9

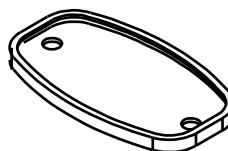

D10

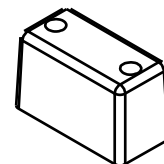

D11

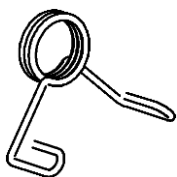

D12



D13



D14



D15



D16

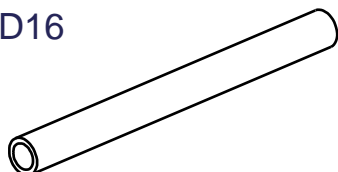

D17



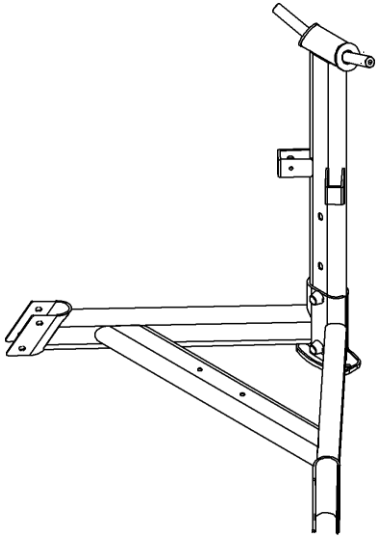

Above shows STEP 1 assembled and completed

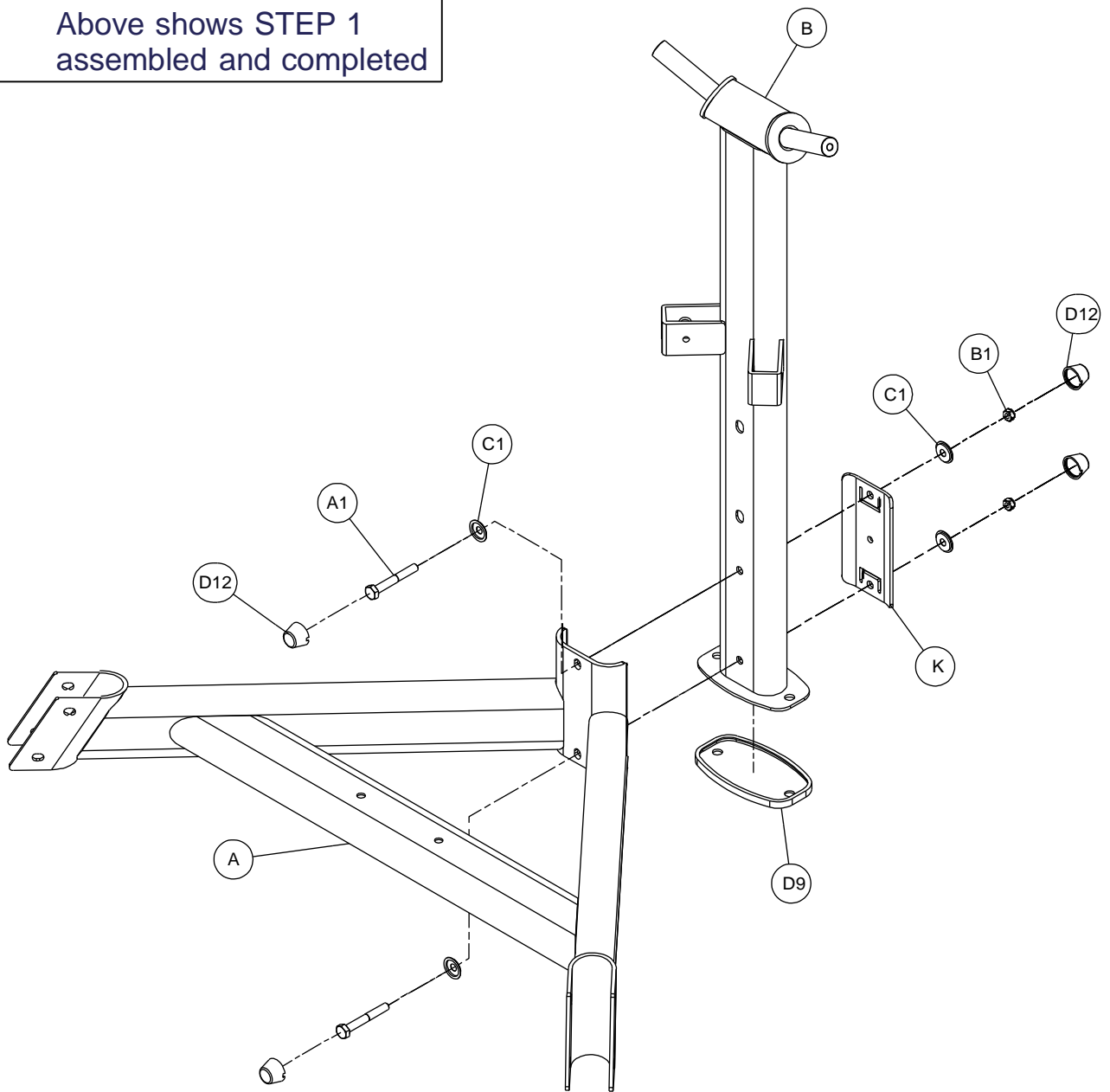

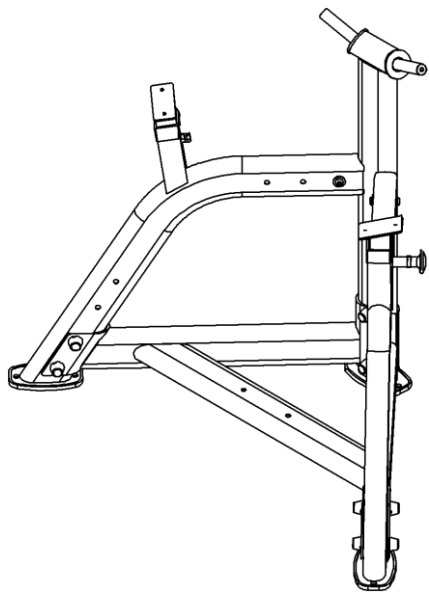

Above shows STEP 2  
assembled and completed

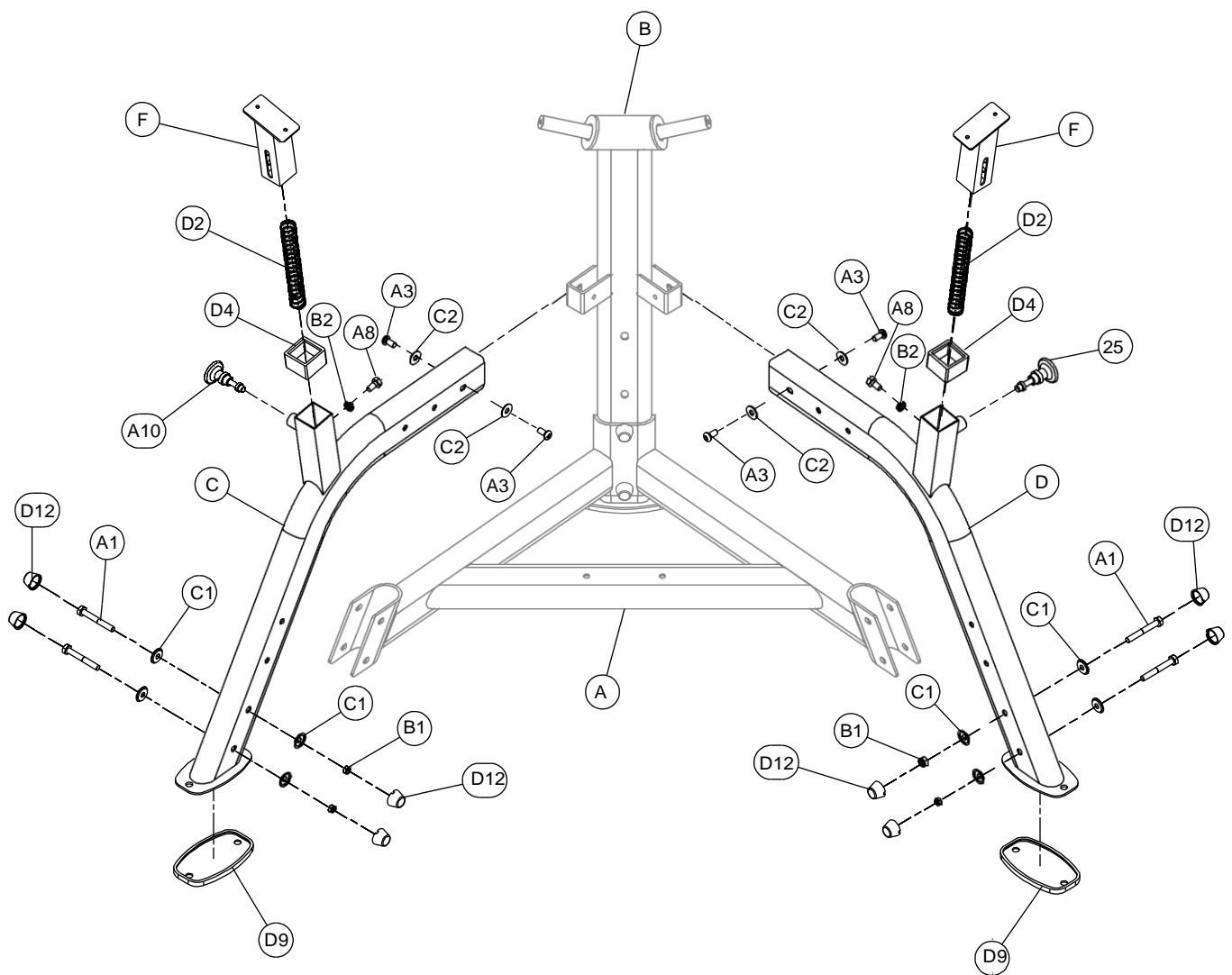



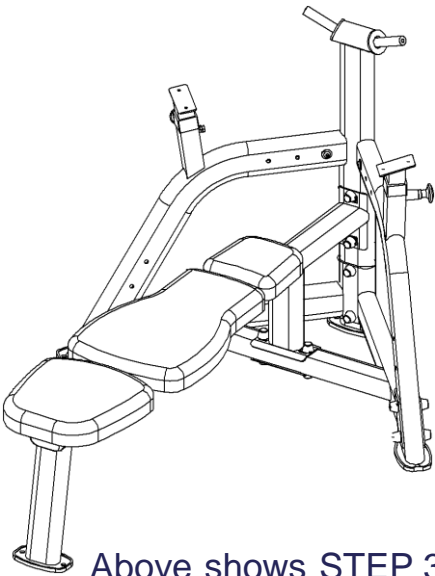

Above shows STEP 3 assembled and completed

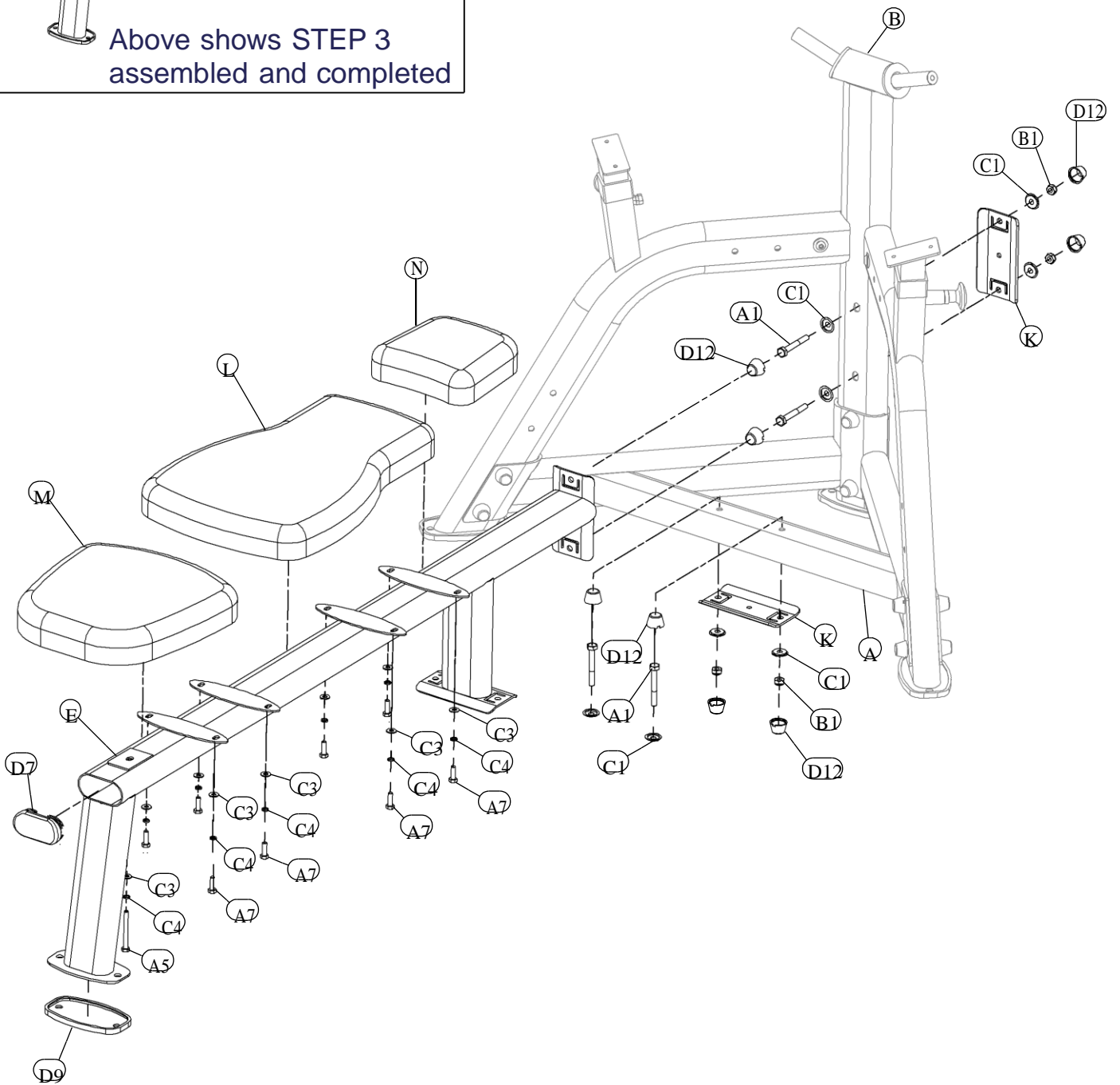

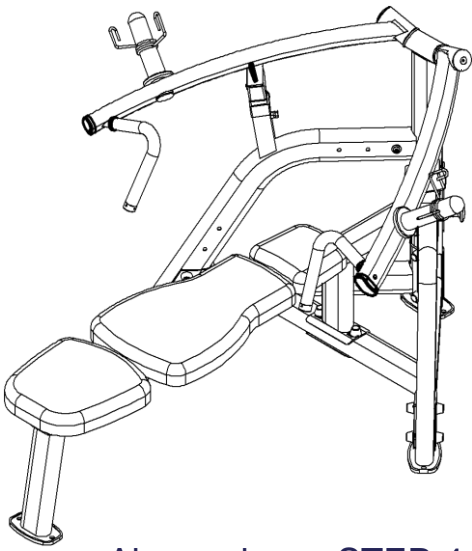

Above shows STEP 4 assembled and completed

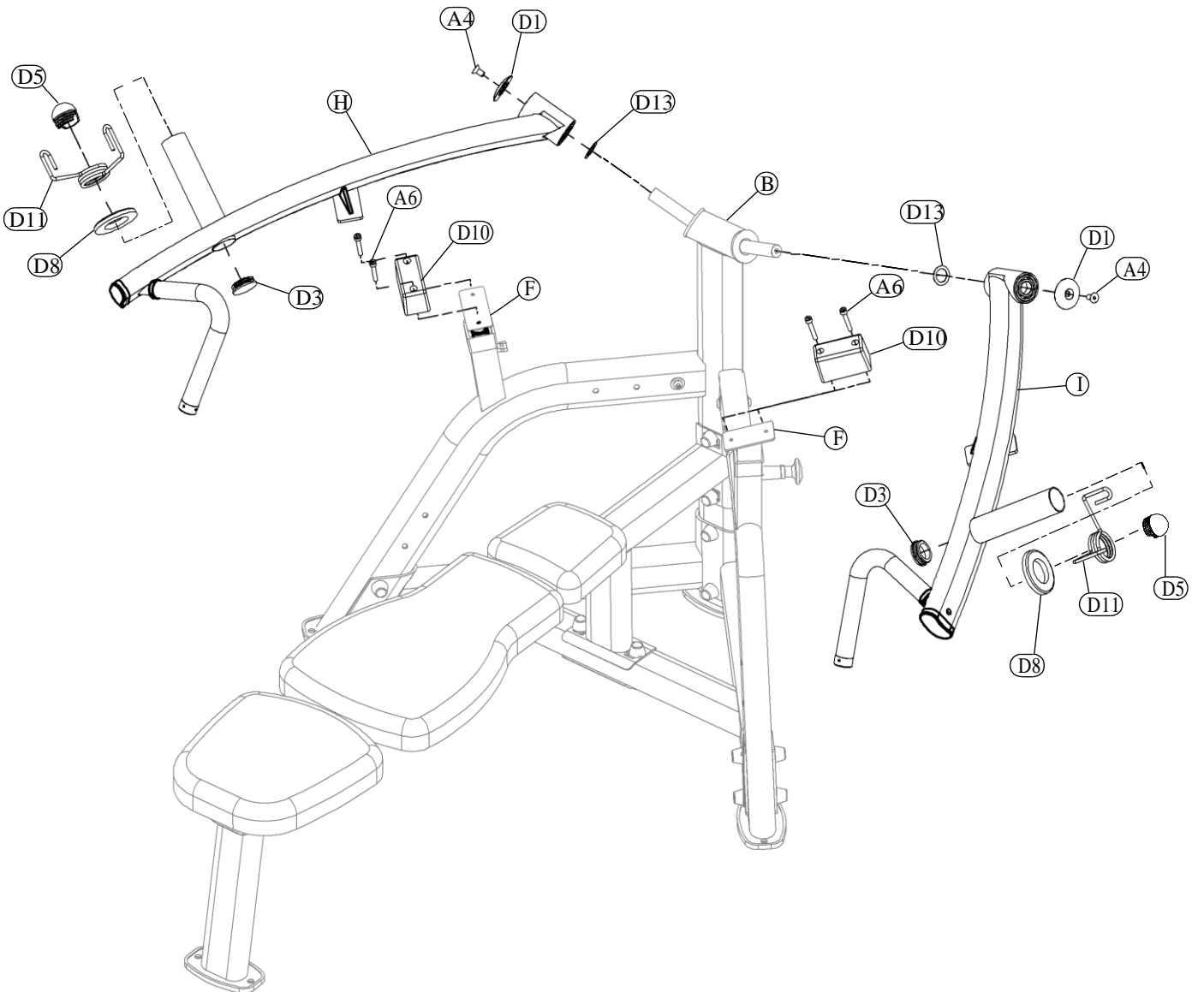

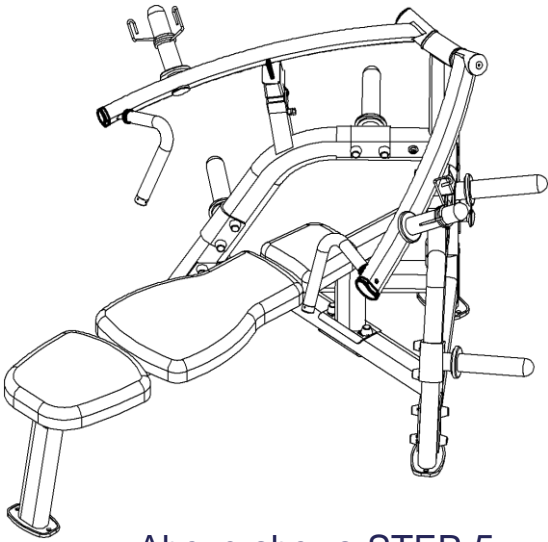

Above shows STEP 5 assembled and completed

