

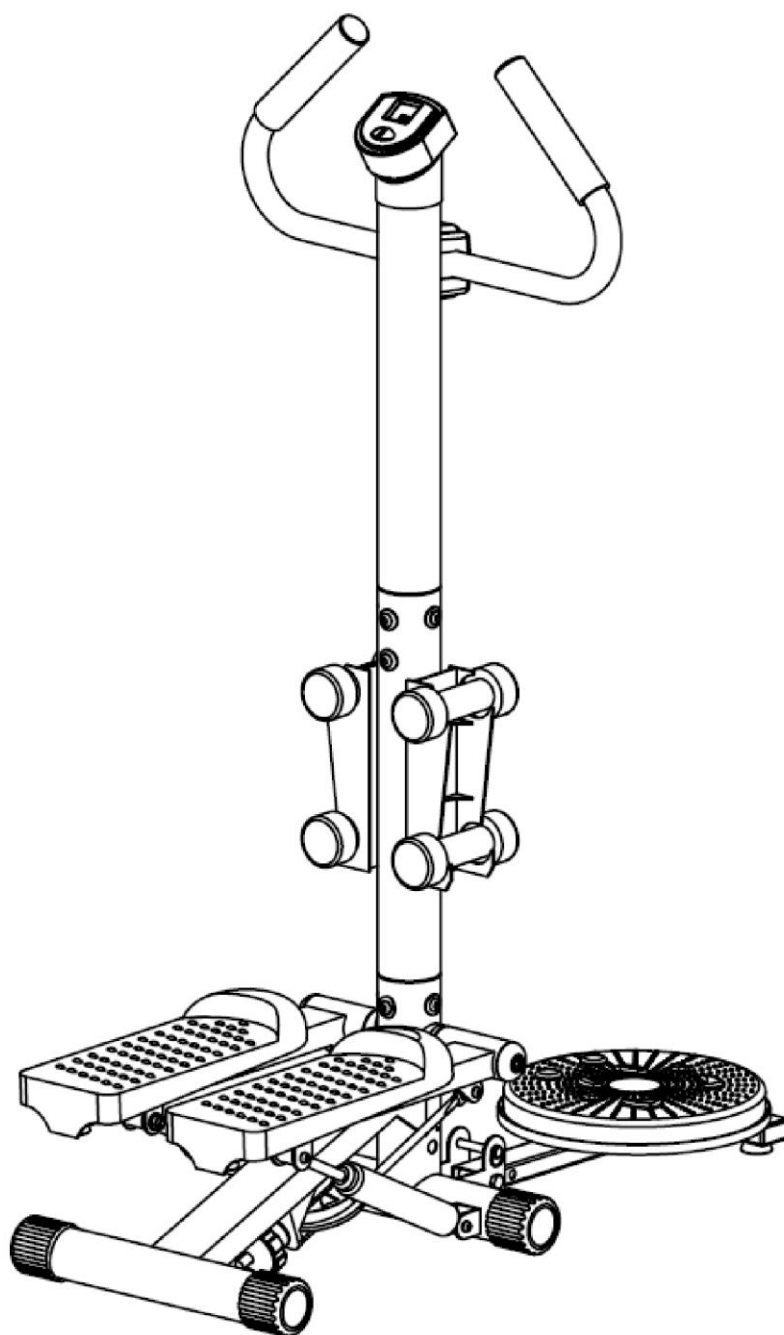

User manual – EN

IN 3883 Multi stepper inSPORTline Easy step(KLJ-303)



IMPORTANT !

Please read all instructions carefully before using this product.

Retain this manual for future reference.

The specifications of this product may vary slightly from the illustrations and are subject to change without notice.

IMPORTANT SAFETY NOTICE

Note the following precaution before assembling and operating the machine.

1. Assemble the machine exactly as the descriptions in the instruction manual.
2. Check all the bolts, nuts and other connections before using the machine for the first time to ensure the machine is in the safe condition.
3. Set up the machine in a dry level place and keep it away from moisture and water.
4. Place a suitable base (e.g. rubber mat, wooden board etc.) beneath the machine in the area of assembly to avoid dirt.
5. Before beginning the training, remove all objects within a radius of 2 meters from the machine.
6. Do not use aggressive cleaning articles to clean the machine. Only use the supplied tools or suitable tools of your own to assemble the machine or repair any parts of machine. Remove drops of sweat from the machine immediately after finishing training.
7. Your health can be affected by incorrect or excessive training. Consult a doctor before beginning the training program. He can define the maximum setting (Pulse. Watts. Duration of training etc) to which you may train yourself and can get precise information during training. This machine is not suitable for therapeutic purpose.
8. Only do training on the machine when it is in correct working way. Use only original spare parts for any necessary repairs.
9. This machine can be used for only one person's training at a time.
10. Wear training clothes and shoes that are suitable for fitness training with the machine. Your training shoes should be appropriate for the trainer.
11. If you have a feeling of dizziness, sickness or other abnormal symptoms, please stop training and consult a doctor immediately.
12. People such as children and handicapped persons should only use the machine in the presence of another person who can give aid and advice.
13. The machine is equipped with adjustable knob at the bottom that can adjust the step height.
14. Maximum user's weight is 100KGS.
15. Class - HC (according to EN ISO 20957) for home use.

WARNING: It will be harmful if you disobey the above-mentioned PRECAUTIONS!

EXPLODED DIAGRAM

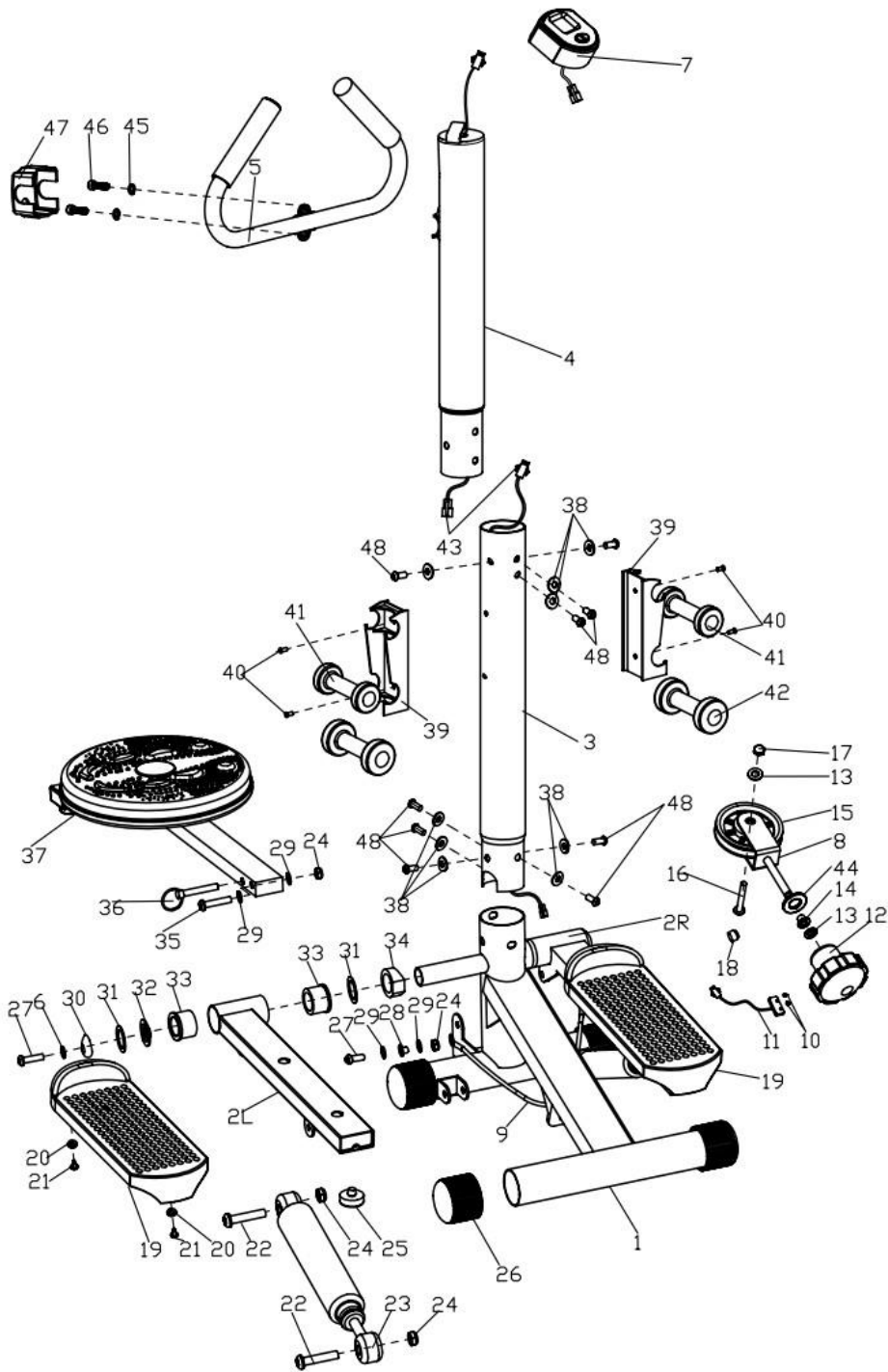

NOTE:

Most of the listed assembly hardware has been packaged separately, but some hardware items have been preinstalled in the identified assembly parts. In these instances, simply remove and reinstall the hardware as assembly is required.

Please reference the individual assembly steps and make note of all preinstalled hardware.

PARTS LIST

Parts No.	Accessory	Quantity	Parts No.	Accessory	Quantity
1	Main Frame	1	26	End Cap	4
2	Left/Right Foot Support	1pr	27	Allen Bolt	4
3	Lower Vertical Tube	1	28	Cable Sleeve	2
4	Upper Vertical Tube	1	29	Flat Washer	6
5	Handlebar	1	30	End Cap	2
6	Computer Bracket	1	31	Big Flat Washer	4
7	Computer	1	32	Cap Washer	2
8	Pulley Frame	1	33	Plastic Bushing	4
9	Steel Cable	1	34	Plastic Arc Washer	2
10	Cross Screw	2	35	Allen Bolt	1
11	Sensor	1	36	Pin	1
12	Knob	1	37	Twister Assembly	1
13	Flat Washer	2	38	Arc Washer	9
14	Guide bushing	1	39	Dumbbell Bracket	2
15	Pulley	1	40	Cross Countersunk Screw	4
16	Hex-head bolt	1	41	Dumbbell(2bls)	2
17	Nylon Nut	1	42	Dumbbell(3bls)	2
18	Round Magnet	1	43	Extension Wire	2
19	Pedal	2	44	Washer	1
20	Flat Washer	4	45	Spring Washer	2
21	Cross Screw	4	46	Hex Socket Cylindrical Bolt	2
22	Allen Bolt	4	47	Handle Chuck Cover	1
23	Cylinder	2	48	Allen Bolt	9
24	Nylon Nut M8	7	49	Flat Washer	2
25	Cushion	2			

ASSEMBLY INSTRUCTION

Prior to assembly of this product, remove all components from the package and verify all the listed parts are supplied. Once certain, begin with the first assembly step.

Step One:

Connect the Extension Wire (43) to the Sensor (11) which is in the Lower Vertical Tube (3), and then insert the Lower Vertical Tube (3) into the Main Frame and fix with Allen Bolt (48) and Arc Washer (38).

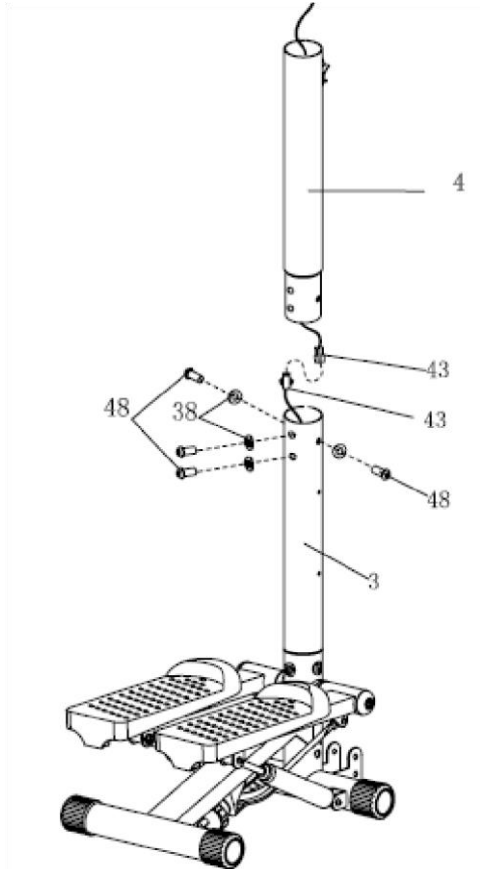

Step Two:

Connect the Extension Wire (43) to the other Wire (43), and then insert Upper Vertical Tube (4) into Lower Vertical Tube (3), then fasten them with Allen Bolt (48) and Arc Washer (38).

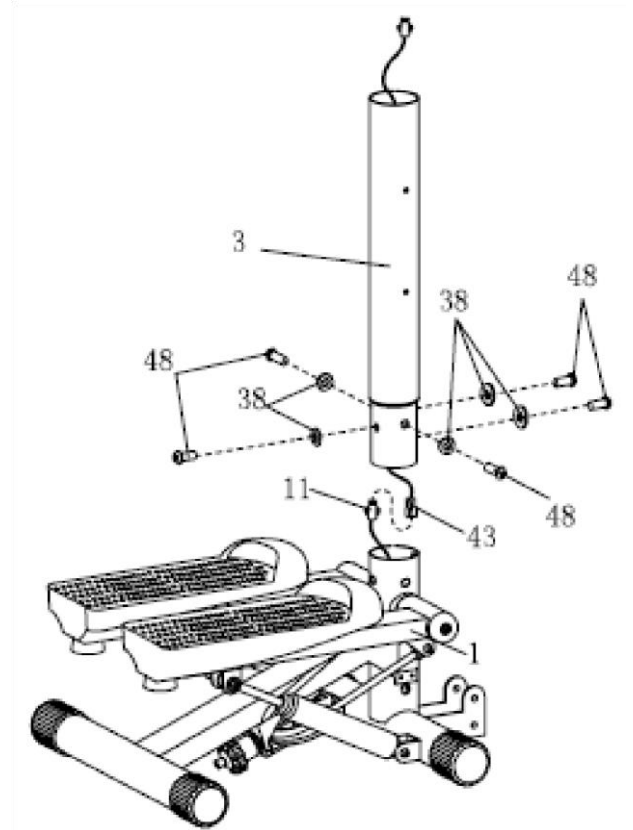

Step Three:

Fix the Handlebar (5) onto Upper Vertical Tube (4) with Hex Socket Cylindrical Bolt (46) and Spring Washer (45) and then cover with the Handle Chuck Cover (47).

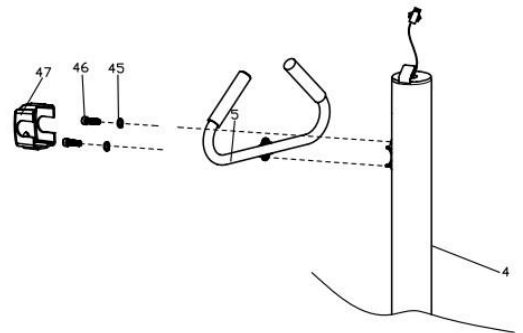

Step Four:

1. Pull the Extension Wire (43) through the hole of Computer Bracket (6), and then insert Computer Bracket (6) onto the Upper Vertical Tube (4).
2. Connect the Extension Wire (43) with the wire coming from Computer (7) well and insert the Computer (7) into the Computer Bracket (6).

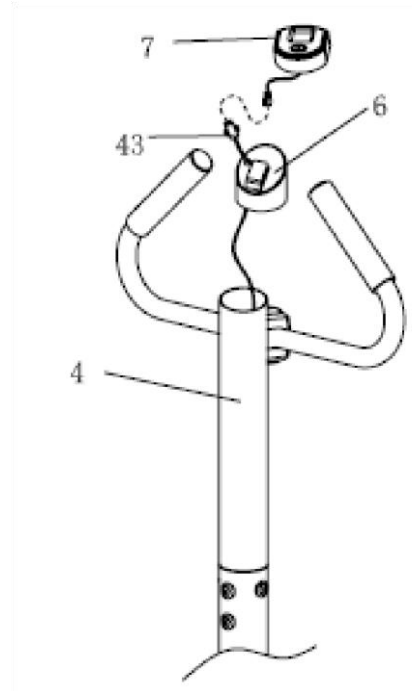

Step Five:

Fix the Twister Assembly (37) onto the Main Frame (1) with Allen Bolt (35), Flat Washer (29) and Nylon Nut (24) as shown.

Note: When you need to fold up the Twister Assembly (37), rotate it up and then fix it onto the Main Frame (1) with Pin (36).

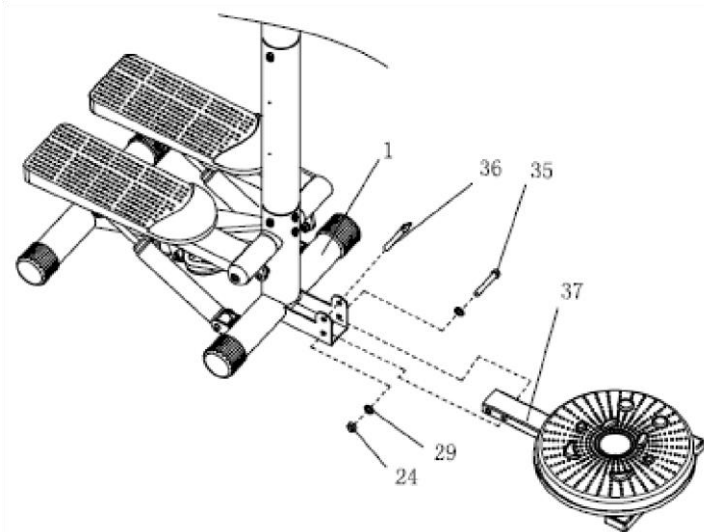

Step Six:

Fix the Dumbbell bracket (39) on the Lower Vertical Tube (3) using Cross Countersunk Screw (40), and then put the Dumbbell (41) and (42) on the Dumbbell bracket (39) as shown.

USING YOUR STEPPER

Using your stepper will provide you with several benefits. It will improve your physical fitness, tone your muscles and in conjunction with a calorie controlled diet, help you lose weight.

WARM-UP PHASE

The purpose of warming up is to prepare your body for exercise and to minimize injuries. Warm up for two to five minutes before strength-training or aerobic exercising. Perform activities that raise your heart rate and warm the working muscles. Activities may include brisk walking, jogging, jumping jacks, jump rope, and running in place.

Exercise Computer

SPECIFICATIONS:

TIME-----00:00 - 99:59 MIN:SEC

COUNT-----0 - 9999 TIMES

CALORIES-----0 - 9999 KCAL STRIDES/MIN-----
-0 - 9999 TIMES/MIN

KEY FUNCTION:

MODE/SELECT: To select the function you want. Hold the key for 4 seconds to have all function values reset(total reset).

OPERATION PROCEDURES:

AUTO ON/OFF .The monitor will be automatically shut off if there is no signal coming in for 4 minutes. The monitor will be auto-powered when start exercise or press the key.

FUNCTION:

<1>.TIME(TMR) Auto-memorize the workout time while exercising.

<2>.COUNT(CNT) Accumulate the steps while exercising.

<3>.CALORIES(CAL) Auto-memorize calories amount consumed while exercising.

<4>.STRIDES/MIN(SPD) (if have). Display the steps per minute while exercising.

<5>.SCAN Automatically scan through each function between①TIME②CALORIES③STRIDES/MIN④

. BATTERY If there is a possibility to see an improper display on

STRETCHING

Stretching while your muscles are warm after a proper warm-up and again after your strength or aerobic training session is very important. Muscles stretch more easily at these times because of their elevated temperature, which greatly reduces the risk of injury. Stretches should be held for 15 to 30 seconds.

DO NOT BOUNCE.

Remember always to check with your physician before starting any exercise program.

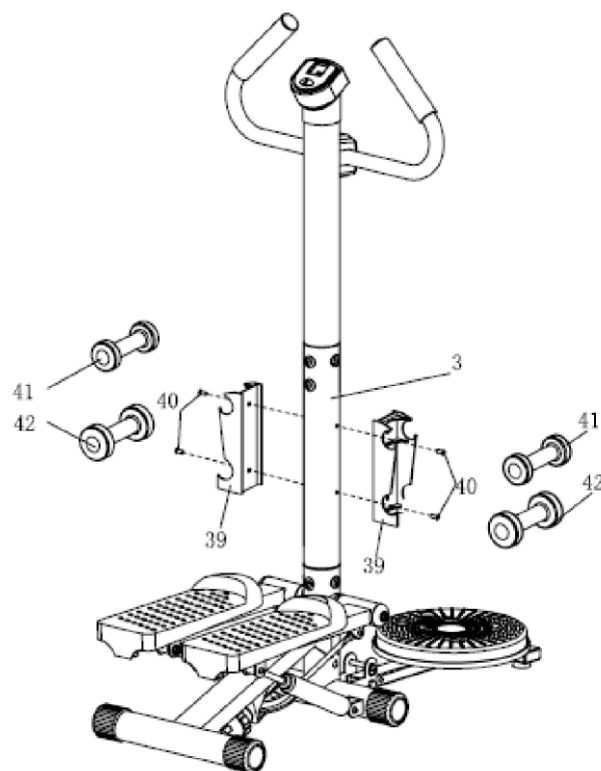

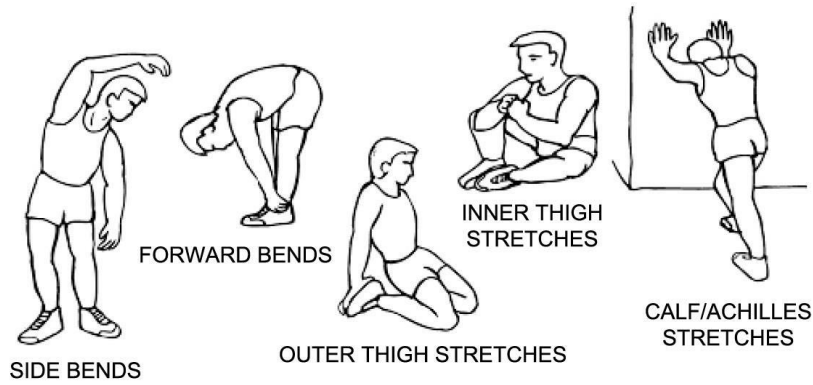

EXERCISE PHASE

This is the stage where you put the effort in. After regular use, the muscles in your legs will become more flexible. Work at your own pace and be sure to maintain a steady tempo throughout. The rate of work should be sufficient to raise your heartbeat into the target zone shown on the graph below.

COOL-DOWN PHASE

The purpose of cooling down is to return the body to its normal or near normal, resting state at the end of each exercise session. A proper cool-down slowly lowers your heart rate and allows blood to return to the heart.

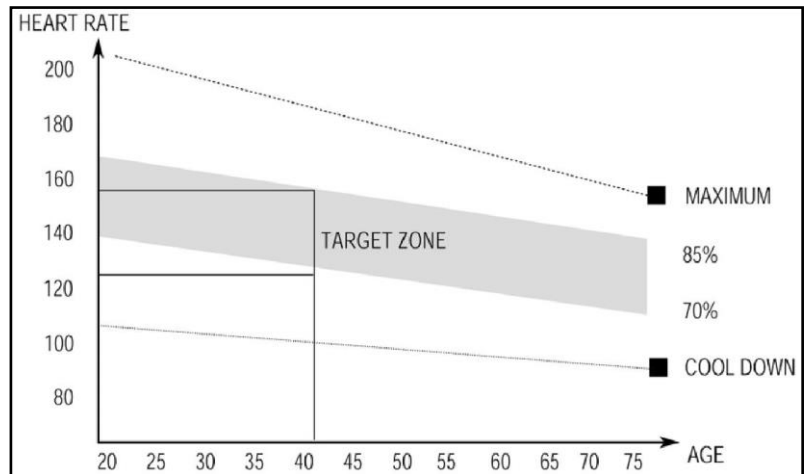



SEVEN SPORT s.r.o.

Sídlo: Bořivojova 35/878, 130 00, Praha 3, ČR
Centrála: Dělnická 957, 749 01 Vítkov
Reklamace a servis: Čermenská 486, 749 01 Vítkov

IČO: 26847264
DIČ: CZ26847264
Telefon: +420 556 300 970
Mail: eshop@insportline.cz
reklamace@insportline.cz
servis@insportline.cz
Web: www.insportline.cz

SK

inSPORTline s.r.o.

Centrála, reklamácie, servis: Električná 6471, 911 01 Trenčín, SK

IČO: 36311723
DIČ: SK2020177082
Telefón: +421(0)326 526 701
Mail: objednavky@insportline.sk
reklamacie@insportline.sk
servis@insportline.sk
Web: www.insportline.sk