

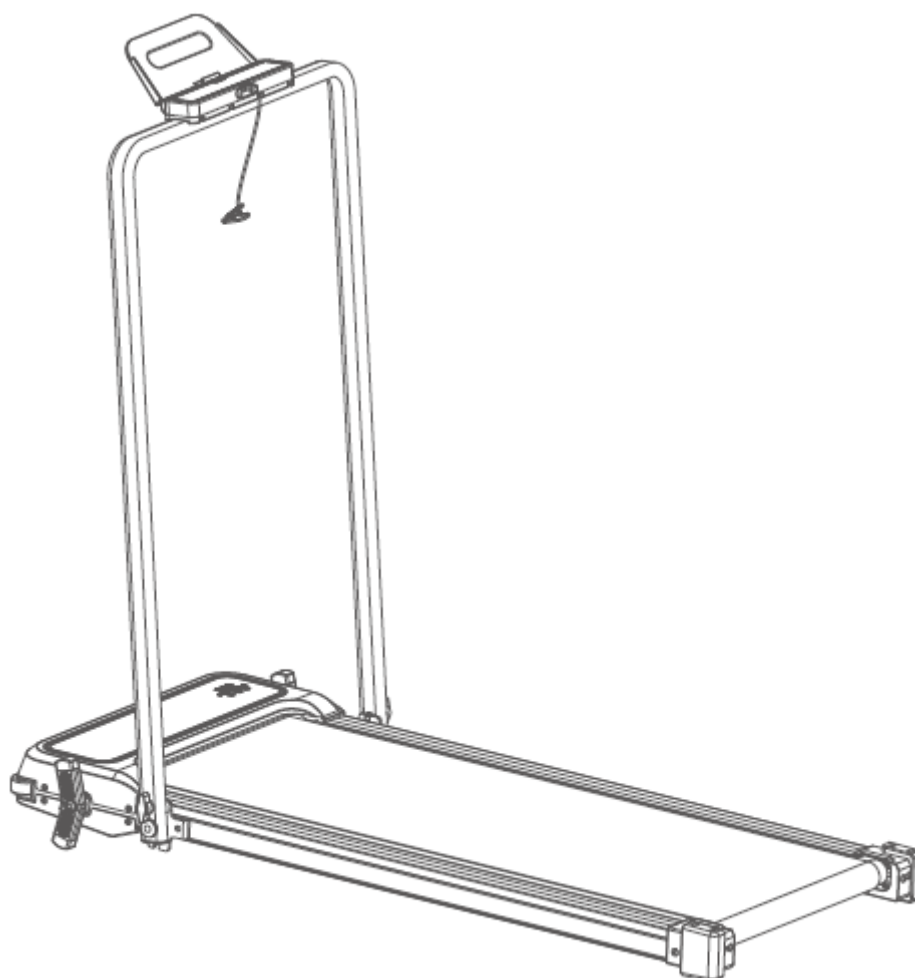

USER MANUAL – EN

**IN 28905 Massage walking treadmill inSPORTline Zenrun
NOON**



CONTENTS

- SAFETY INSTRUCTIONS..... 3
- SPECIFICATIONS..... 4
- PACKAGE CONTENTS 5
- PRODUCT DESCRIPTION 6
- USE 7
 - WALKING (speed 1 – 12 km/h) 7
 - MESSAGE SIDE (speed P1 – P5)..... 8
- SAFETY KEY..... 9
- TRANSPORT..... 9
- CONSOLE 10
 - WALKING SIDE 10
 - MESSAGE SIDE..... 11
 - FRAME CONTROLS 12
 - REMOTE CONTROL 12
- MAINTENANCE AND STORAGE 12
 - REGULAR INSPECTION..... 13
- SAFE EXERCISING 13
- GETTING START 14
 - WARM – UP EXERCISE 14
- STORAGE 15
- IMPORTANT NOTICE..... 15
- ADJUSTING THE WALKING BELT 16
- LUBRICATING THE TREADMILL..... 16
- CLEANING 17
- ERROR CODES..... 17
- TROUBLESHOOTING 17
- ENVIRONMENT PROTECTION 18
- TERMS AND CONDITIONS OF WARRANTY, WARRANTY CLAIMS..... 18

SevenSport s.r.o. reserves the right to make any changes and improvements to its product without prior notice. Visit our website www.insportline.eu where you will find the latest version of the manual.

SAFETY INSTRUCTIONS

- Read the manual carefully and keep it for future reference.
- Always clip the safety key to your clothes or belt before starting exercising.
- Move naturally, forward. Do not look on your feet. Only one person can use the device at the same time.
- Speed increase gradually, not instantly.
- In case of danger, press the stop button or pull out the safety key.
- Leave the device after it stops moving.
- Follow the assembly instructions. Assembly can be done by an adult person.
- Keep away from kids and pets. Do not leave kids and pets unattended near the treadmill. Treadmill is for adults only.
- Before starting any exercise, program ask your physician. It is important if you have health issues or ongoing treatment or have high blood pressure.
- Regularly check all bolts and nuts. They must be tightened properly. Regularly check the treadmill for damage or signs of wear. Do not use damaged or wear treadmill.
- Regularly check the treadmill for signs of wear or damage. If any sharp edge appears stop using the treadmill.
- Place the treadmill on flat, dry and cleat surface. Keep safety distance of at least 0.6 m around the treadmill. Do not use in humid areas. Do not place the treadmill on thick carpet.
- If the power cable is damaged do not use the device. Buy new one in authorized shop.
- Protect the treadmill from humidity and water.
- Place the treadmill not to cover socket.
- Do not use aerosol sprays in the area around treadmill.
- If the treadmill is running, do not remove the protective cover. If you need to remove the protective cover during maintenance, unplug the treadmill from the socket.
- Always wear sport clothes. Do not wear loose clothes that can get stuck. Always wear sport boots.
- The treadmill also includes a massage side of the running surface, if necessary, you can walk on the belt without shoes at a lower speed.
- Do not turn on the treadmill if you are standing on it. There is a delay when you turn on the treadmill. Before starting the treadmill stand on the side.
- Do not exercise 40 min after eating food.
- Always do warmups before exercise.
- Do not place foreign objects in ventilation or sockets.
- Maintenance should be done only according to the manual, to prolong the lifespan.
- Do not modify the product.
- Exercise reasonably and do not overextend. If you exercise for the first time, hold your handles firmly until you get used to the device.
- In case of error or damage stop the exercise immediately. If the treadmill suddenly increases its speed, remove the safety key.











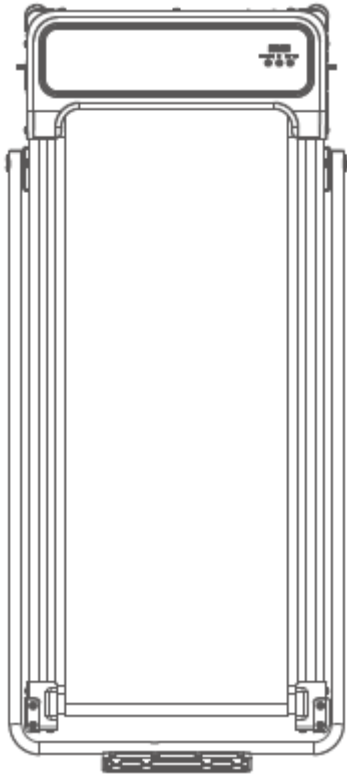

- Connect the treadmill to socket after the treadmill is assembled. Use only grounded socket.
- If you are not using the device unplug it from socket and safety key removed.
- Any part of the treadmill cannot prohibit the movement of the user.
- Do not use outdoors.
- Do not expose to direct sunlight.
- Do not place in areas with high humidity (pools, sauna etc.)
- Continuous use cannot be longer than 2 hours.
- If the treadmill is not in use, remove the safety key.
- **Operation temperature:** 5 – 40 °C
- **Max. user weight:** 120 kg
- **Category:** HC for home use

SPECIFICATIONS

Dimensions (folded)	1260x550x130 mm	Maximum speed (walking)	12 km/h
Running surface	1000x400 mm	Maximum speed (massage surface)	1.4 km/h
Gross weight	27 kg	Minimum speed	1 km/h
Net weight	24 kg	Voltage	220-240V ~
Load capacity	120 kg	Power	0,75 HP
Dimensions (unfolded)	1205x550x1070 mm		



PACKAGE CONTENTS

		
	Remote controller, 1x	Frame support, 2x
		
	Wrench, 1x	Safety key, 1x
		
	Oil, 1x	Tablet holder, 1x
Walking treadmill, 1x		
		
Manual, 1x	Allen bolt M8x30x2, 2x	Washer, 2x

PRODUCT DESCRIPTION

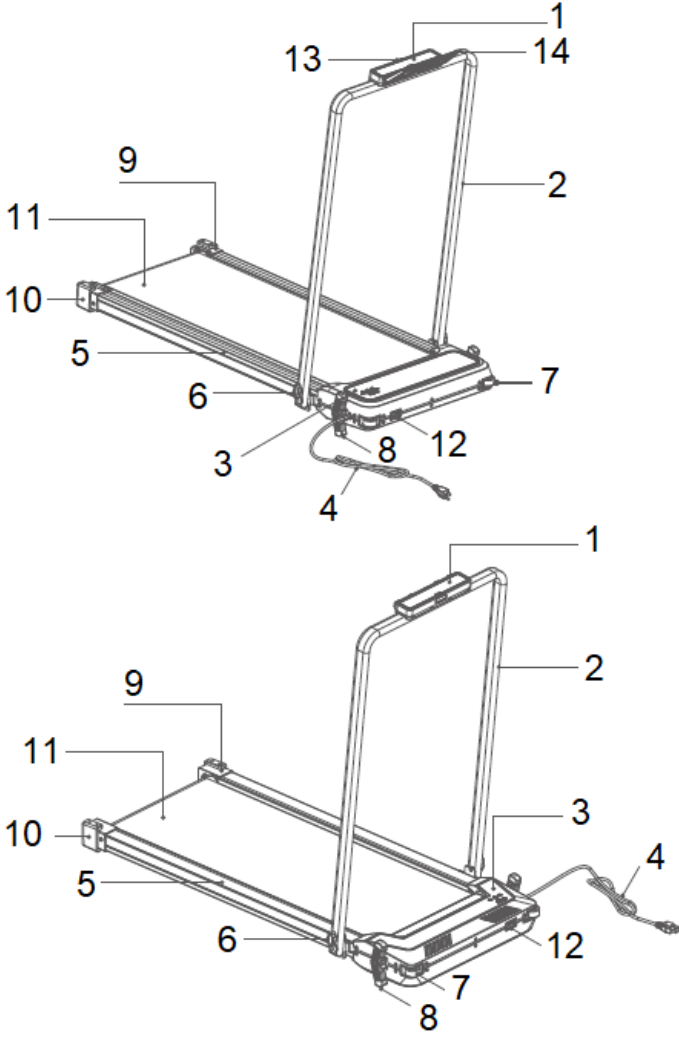

- | |
|----------------------|
| 1. Console |
| 2. Post |
| 3. Display panel |
| 4. Power cord |
| 5. Footrests |
| 6. Handlebar shift |
| 7. Transport wheels |
| 8. Frame support |
| 9. Rear left cover |
| 10. Rear right cover |
| 11. Treadmill |
| 12. Power switch |
| 13. Safety key |
| 14. Tablet holder |

USE

For safety reasons, before changing the use (massage side / non-massage side), it is necessary to turn off the treadmill and wait until the display on the treadmill goes out. Then it is safe to switch the control panel and change the walking surface type. If you do not turn off the treadmill when changing sides, the control panel will not turn on.

WALKING (speed 1 – 12 km/h)

1. Remove all parts from the box and make sure that no parts are missing.
2. Attach the supports as shown.

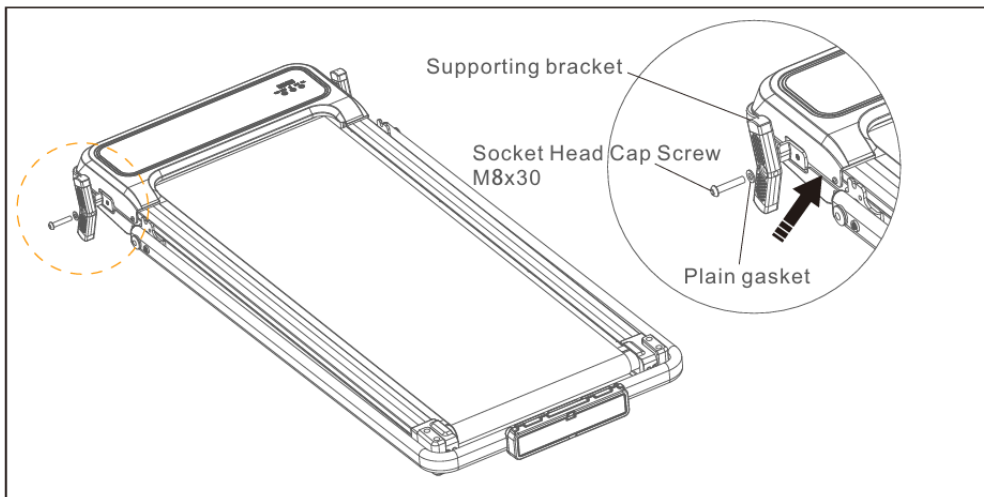

3. Lift the handlebar posts. Align the holes in the posts with the holes in the frame and tighten with the hand screw.

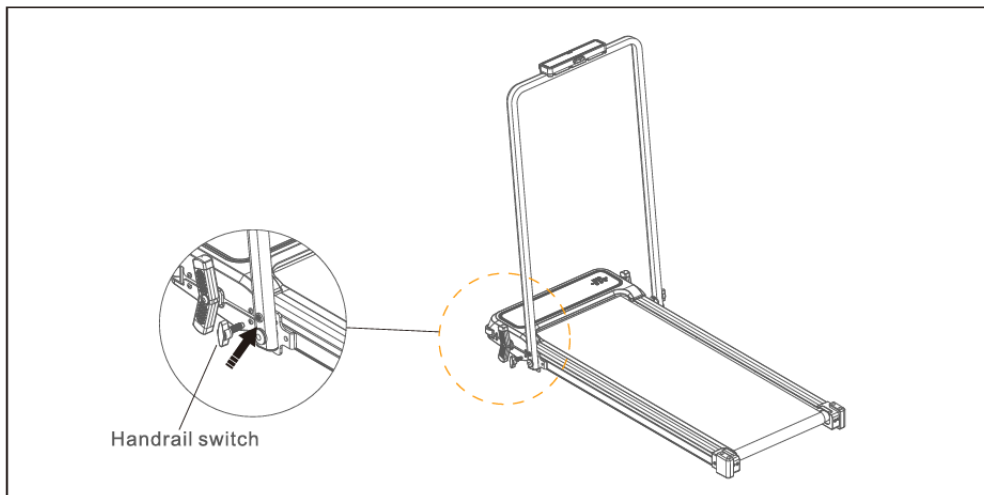

4. Attach the tablet holder as shown.

5. Turn the power switch to the on position.

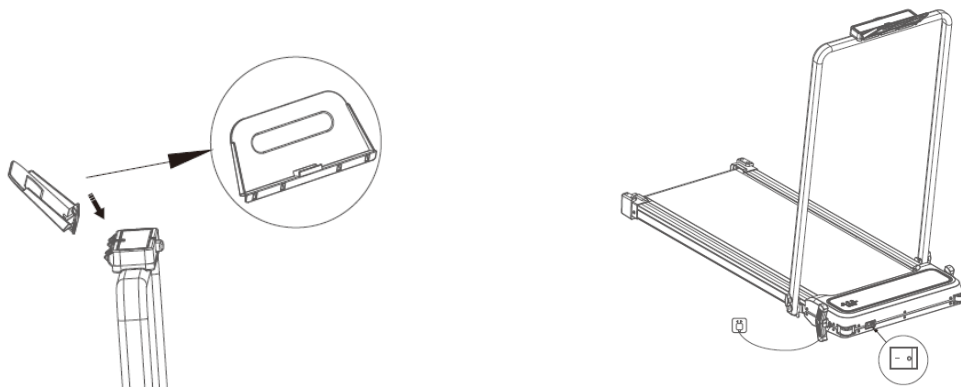

MESSAGE SIDE (speed P1 – P5)

1. Turn the treadmill to the massage side.
2. Remove the tablet holder and fold the handles as shown.
3. Lift the columns with the control panel and secure with the hand screw on the bottom.
4. Remove the tablet holder

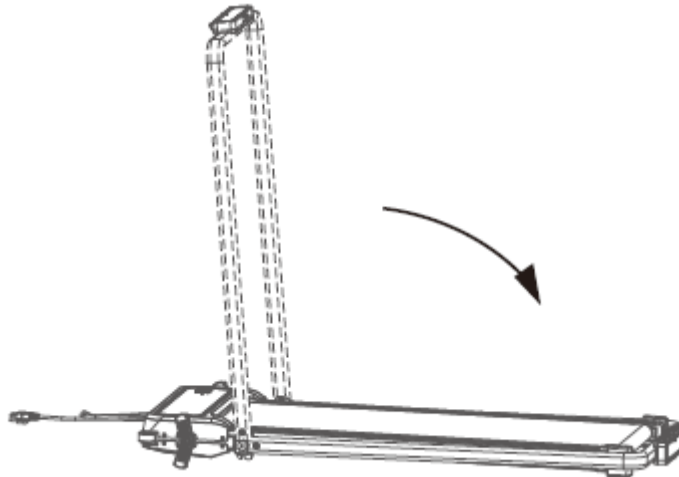

When rotating the running surface, it is always necessary to attach the control panel correctly. Press the button in the picture to remove the control panel and attach it as shown in the picture.

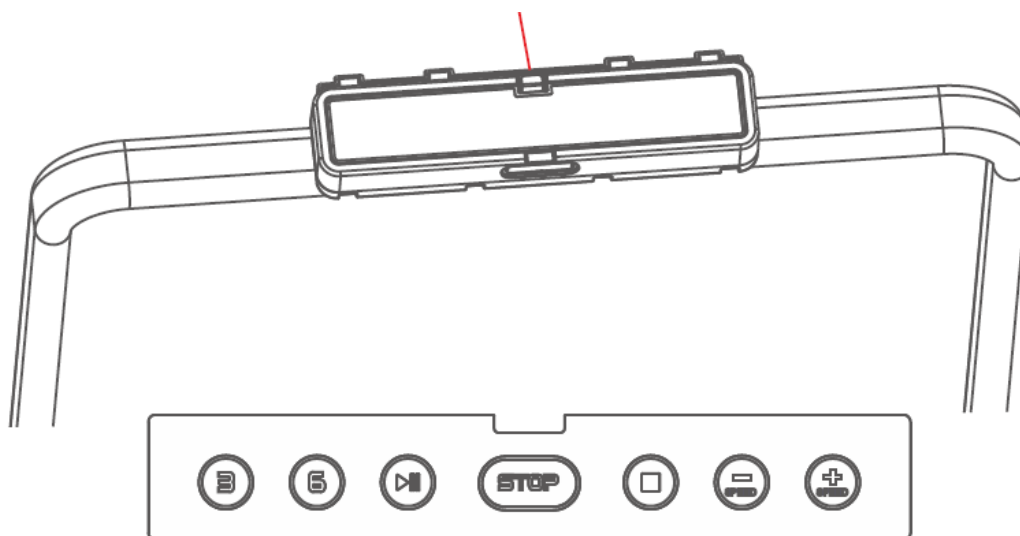

SAFETY KEY

Before use, clip the safety key to your clothing. In case of a malfunction, pull out the safety key, the treadmill will stop and the display will show " - - -".

The end (A) is used to attach it to clothing, the end (B) is attached to the console.



TRANSPORT

Before moving, it is necessary to turn off the main switch and disconnect from the power supply.

Move the treadmill in a vertical position on the transport wheels as shown in the picture.

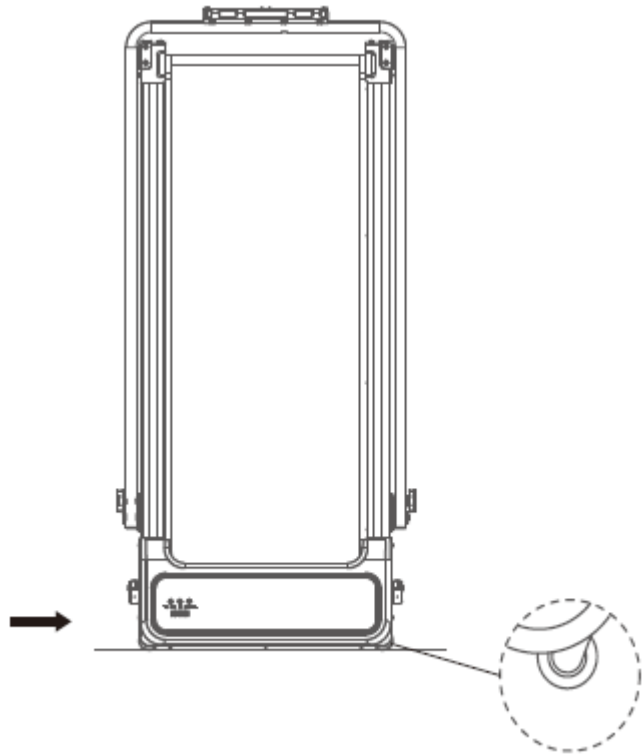

CONSOLE

Power saving mode





The console is equipped with a power saving mode that starts after 10 minutes of inactivity. After switching to power saving mode, the measured data is reset. You can wake up the console by pressing any button.

WALKING SIDE

CONTROLS

When controlled via the control panel on the handle, the maximum speed that can be set is up to 12km/h.

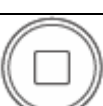

	Decrease speed Press or hold to decrease speed by 0.5 km/h
	Set speed Press or hold to gradually change speed to 3 km/h
	Start / pause Starts the treadmill at a speed of 1 km/h Pauses the program, press again start the program
	Stop Press to stop the program
	Set speed Press or hold to gradually change the speed to 6 km/h
	Increase speed Press or hold to increase speed by 0.5 km/h

DISPLAY



Speed	1.0 – 12.0 km/h	Displays speed
Distance	00.00 – 99.99 km	Displays distance
Time	00 – 99 min	Displays workout time
Calories	0 – 9999 Kcal	Displays calories burned
IR		Infrared remote receiver

The maximum time value is 99 minutes, after which the console will be restarted.

MESSAGE SIDE

CONTROLS



	Decrease speed Press or hold to decrease speed by 0.5 km/h
	The button is not active when used on the message side.
	Start / pause Starts the treadmill at P1 speed Pauses the program, press again start the program
	Stop Press to stop the program
	The button is not active when used on the message side.
	Increase speed Press or hold to increase speed by 0.5 km/h

DISPLAY



Speed	P1: 1.0 km/h, P2: 1.1 km/h, P3: 1.2 km/h, P4: 1.3 km/h, P5: 1.4 km/h	Displays speed
Time	00 – 99 min	Displays training time
IR	Infrared remote receiver	

FRAME CONTROLS

Both sides of the treadmill can be controlled using the buttons on the bottom. (If you want to use the buttons, for your safety, you must first get off the treadmill)

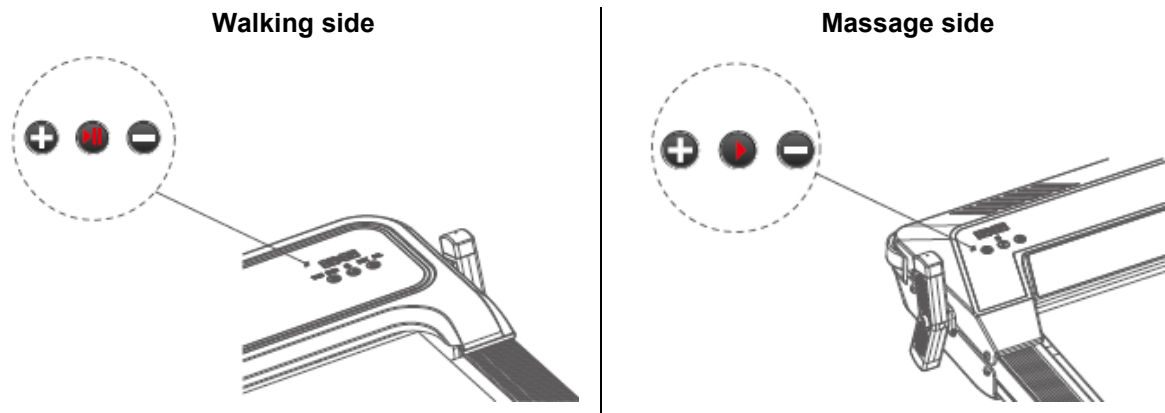

REMOTE CONTROL

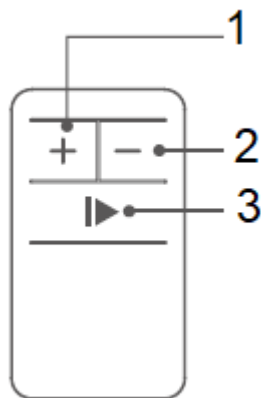

1. Increase speed

2. Decrease speed

3. Start / Pause

Walking

When controlled via the remote control, the maximum speed that can be set with the remote control is up to 6km/h.

1. Press or hold to increase the speed by 0.5 km/h.
2. Press or hold to decrease the speed by 0.5 km/h.
3. Start the treadmill at 1 km/h. Pause the program, press again to start the program

Massage side

1. Press or hold to increase the speed by one gear.
2. Press or hold to decrease the speed by one gear.
3. Start the treadmill at P1 speed. Pause the program, press again to start the program

MAINTENANCE AND STORAGE

STORAGE

Store the treadmill in a dry and dark place. Protect from dust. Unplug from the wall outlet (if applicable) before storing.

The durability and safety of the device can only be guaranteed if the product is regularly checked for damage or wear.

Never remove protective covers.

The treadmill is for indoor use only, do not use in damp areas.

Check all bolts and nuts regularly for tightness.

MAINTENANCE

Always use a soft, cotton cloth and a non-aggressive detergent for cleaning.

Never use aggressive cleaning agents based on alcohol or petrol.

REGULAR INSPECTION

DAILY

- Before each use, make sure that no object in the area prevents the user from moving freely.
- Before each use, check that the belt edges are properly locked and check for wear.
- After each use, wipe away sweat and moisture.
- Clean the console display with a damp, soft cotton cloth. Avoid using too much water.

WEEKLY

- Clean the plastic cover properly.
- Clean handles and display
- Check that the edges are securely locked.
- Check all screws, nuts for wear and tightness.

MONTHLY

- Lubricate all metal ends with corrosion protection.
- Check the AAA battery level in the console, replace if necessary.
- Clean the running surface.

We do not recommend performing any internal corrections / adjustments.

The use of any means other than cleanser and lubricant may reduce the product life.

SAFE EXERCISING

Please consult your doctor before starting any exercise program. They can recommend the frequency, intensity and duration of the exercise based on your age and health condition. If you feel any or similar symptoms during exercising – pain or tightness on the chest, irregular heart rate, shortness of breath, dizziness or other discomfort - please stop immediately! Consult your doctor before you continue exercising. If you use the treadmill often, you can choose regular walking speed or jogging speed. If you have no experience or aren't sure what the best initial speed for you is, refer to the data below:

Speed 1 - 3.0 km/h	people with weak constitution
Speed 3.0 - 4.5 km/h	people who do not exercise often
Speed 4.5 - 6.0 km/h	normal walking speed
Speed 6.0 - 7.5 km/h	fast walking
Speed 7.5 - 9.0 km /h	jogging
Speed 9.0 - 12.0 km/h	intermediate speed runner
Speed 12.0 - 14.5 km/h	experienced runner
Speed over 14.5 km/h	excellent runner

ATTENTION:

- Users who want to exercise while walking should choose 6 km/h speed or lower.
- Users who want to exercise while running should choose 8 km/h speed or higher.

GETTING START

PREPARATION

If you are more than 45 years old or have health problems and this is your first time using a treadmill, please consult your doctor before exercising.

Before you use the motorized treadmill, please stand aside and learn how to use it, e.g. how to start, stop and adjust the speed. You can use it after you familiarize yourself with its functions.

EXERCISE

Stand aside to learn how to operate the machine (adjusting the speed and inclination). Start exercising after you familiarize yourself with the functions. Walk 1 km in a constant tempo and record the time it takes, which may be about 15 - 25 minutes. Walk 1 km by 4.8 km/h (you need about 12 minutes). After successfully completing this exercise a few times you can adjust to a higher speed and inclination. Have a good 30-minute exercise. When you do walking exercises do not rush. The exercise improves your health.

FREQUENCY

The optimal exercise frequency is 3 - 5 times per week for 15 – 60 min. It is better to make a schedule first and not exercise randomly. You can control the intensity of the movement through adjusting the speed and inclination. We suggest not to set the inclination when at the start of the exercise. When you want to increase the intensity of the exercise, change in inclination will be the most effective.

HOW TO EXERCISE

It is best for each exercise to last 15 – 20 min. Warm up for 2 minutes by walking 4.8 km/h, then increase the speed to 5.3 km/h, and then 5.8 km/h. Each section should take about 2 minutes. Then add 0.3 km/h per 2 mins, until your breathing quickens (You should have no difficulty though). Keep exercising at this speed. If you feel it is hard to breathe, lower the speed by 0.3 km/h. Finally, leave 4 minutes to reduce the speed at last. If you find increasing the intensity by increasing speed too hard, you can slowly increase the inclination. Just a small adjustment can increase the intensity greatly.

BURNING CALORIES - This way allows you to burn calories. Warm up for 5 minutes at 4 – 4.8 km/h speed, then add 0.3 km/h per every 2 minutes. Keep increasing the speed until you feel it is a challenge to do the exercise continually for 45 minutes. In order to increase intensity, you can try to exercise for 1 hour at this speed. You can exercise while watching TV. Add 0.3 km/h speed every time you see advertisements and return to the former speed by the end of the advertisement so that you increase the intensity only during advertisements. Slow down for at least 4 minutes.

CLOTHING

All you need is a pair of shoes, which let you stretch your feet fully and at the same time don't stick to foreign matters under your shoe's soles, so that you do not carry dirt onto the running belt and running board. The dirt and other foreign matter could damage them both. You should wear comfortable clothes.

WARM – UP EXERCISE

It is better to do some warm-up exercises before running. Warmed muscles are easy to stretch, so take the time to do 5 – 10-minute warm-up. Repeat each exercise shown in the pictures below.



Touch toes

Bend your knees slightly and slowly stretch your body downwards.

Relax your back and shoulders. Try to touch the toes. Keep the position for 10 - 15 seconds. Repeat approx. 3 times.



Hamstring stretches

Sitting on a cushion, stretch one leg straight and fold the other inward. Pull it as close to your body as you can. Try your best to touch the toes and keep the stretch for 10 – 15 seconds. Repeat 3 times for each leg.



Calves and Achilles tendon stretches

Support yourself with two hands on a wall or a tree with one leg stretched behind you. Keep the leg straight and the heel on the ground. Keep the position for 10 - 15 seconds. Repeat 3 times for each leg.



Quadriceps stretches

Support yourself with your right hand on the wall or a table and stretch your left hand backwards to hold your ankle. Pull it towards your buttocks until you feel tension in your thigh. Keep the position for 10 - 15 seconds. Repeat 3 times for each leg.



Inner thigh stretches

Sit down with your soles touching and knees outward. Pull your feet towards your groin. Keep the position for 10 - 15 seconds. Repeat 3 times.

STORAGE

Keep the treadmill in a clean and dry environment. Make sure the power switch is turned off and the treadmill is not plugged into the power socket.

IMPORTANT NOTICE

- This treadmill comes with standard safety regulations and is suitable for home use. Any other use is prohibited and may be dangerous to users. We are not responsible for any injury caused by improper and forbidden use of the machine.
- Consult your doctor before starting training on the treadmill. Your doctor should evaluate whether you are physically fit to use the machine and how much effort you are able to undergo. Incorrect exercise or switching of the body can harm your health.
- Carefully read the following tips and exercises. If you experience pain, nausea, breathing, or other health problems during exercise, immediately stop the exercise. If the pain persists, contact your doctor immediately.
- This treadmill is not suitable for medical purposes. It can also not be used for healing purposes.
- The heart rate monitor is not a medical device. It provides only approximate information about your average heart rate, and any suggested pulse rate is not medically binding. Accumulated data may not always be accurate regarding uncontrollable human and environmental factors.

ADJUSTING THE WALKING BELT

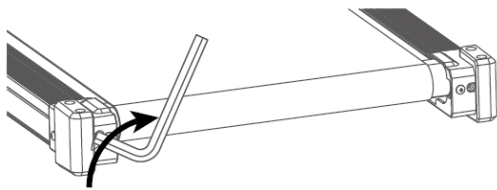

Fig. 1

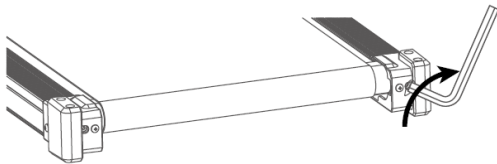

Fig. 2

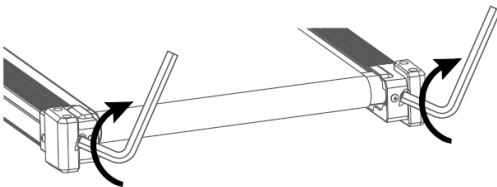

Fig. 3

Walking belt centering

Turn the treadmill off and unplug it.

If the treadmill deviates to the left, use a wrench to turn the screw clockwise by $\frac{1}{4}$. (Fig. 1)

If the belt deviates to the right, use a wrench to turn the screw clockwise by $\frac{1}{4}$. (Fig. 2)

Then let the treadmill run for 1 – 2 minutes to check the belt centering.

Belt slipping

Turn the treadmill off and unplug it.

Use a wrench to turn both roller screws by $\frac{1}{2}$ a turn. (Fig. 3)

After adjusting, let the treadmill run for 1 – 2 minutes at a speed of 3 – 4 km/h.

Do not overtighten the rollers, otherwise there is a risk of damage.

LUBRICATING THE TREADMILL

Lubricating the running belt & the running board is essential as the friction affects the life span and operations of the treadmill. Therefore, we suggest you to inspect the running belt regularly.

WARNING: Always unplug the treadmill from the electrical outlet before cleaning, lubricating, or repairing the unit.

We recommend following the lubrication chart below:

Light user (less than 3 hours/week)	Every 6 months
Medium user (3 - 5 hours/week)	Every 3 months
Heavy user (more than 5 hours/week)	Every 2 months

How to lubricate the treadmill:

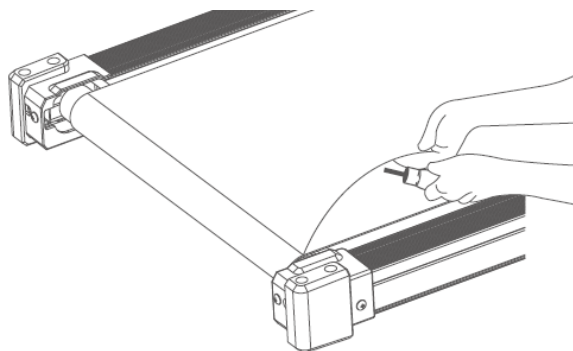

Turn off and unplug the treadmill.

Using a wrench, loosen the belt by loosening the rollers counterclockwise. (note the number of turns)

Lift the belt and apply 5-10 ml of oil to the center of the running plate.

Tighten the rollers the same number of turns that you loosened them.

Turn on the treadmill to distribute the oil evenly.

Before each lubrication of the treadmill, first test the oil film by touching the plate under the belt. There should be a light oil film on the board, which will also remain on your fingers. If this is not the case, lubricate the treadmill. It is generally recommended to use approximately 10 ml of oil into the appropriate area and then let the treadmill run at the lowest speed for a few minutes without load. After that check again whether a fine oil film has formed on the board under the belt. **ATTENTION!** Over

lubrication of the treadmill is not desirable and usually requires specialist service. It is therefore better to pour less oil and add more as needed.

CLEANING

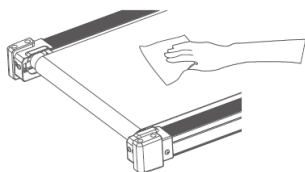

Turn off and unplug the treadmill.

Clean the running surface with a damp cloth. Do not use harsh cleaning agents.

Do not clean the reverse side of the belt.

ERROR CODES

In the event of any error, stop operation immediately and do not use the treadmill until the cause of the error has been corrected.

For any repair, it is necessary to first turn off the belt and disconnect it from the power supply.

E01	Communication error between control unit and display	Check the connection of the control unit and display Contact the service department
E02	Overheating protection	Check the connection of the control unit and the motor Check the connection of the power supply Contact the service department
E03	Motor short circuit	Contact the service department
E04	Surge protection	Load higher than 120 kg Check the smooth running of the motor and all moving parts Tightened rollers or insufficiently lubricated belt
E07	Software error	Replace the control unit
E10	Error between signal transmission cable to console	Check the cable and console connection Check the console cables Replace the circuit board

TROUBLESHOOTING

Cannot start	1. Damaged power terminal 2. Power supply has been interrupted 3. Damaged power cable	1. Check the terminal and plug 2. Make sure the cable is connected correctly 3. Replace the cable
Belt slips	Loosed belt	Tighten the belt
Remote control does not work	1. Signal is blocked 2. Low battery 3. Controller damaged	1. The remote control does not have a direct signal with the receiver 2. Replace the battery 3. Replace the remote control
Friction sounds	The belt is not centered.	Center the belt

ENVIRONMENT PROTECTION

After the product lifespan expired or if the possible repairing is uneconomic, dispose it according to the local laws and environmentally friendly in the nearest scrapyards.

By proper disposal you will protect the environment and natural sources. Moreover, you can help protect human health. If you are not sure in correct disposing, ask local authorities to avoid law violation or sanctions.

Don't put the batteries among house waste but hand them in to the recycling place.

TERMS AND CONDITIONS OF WARRANTY, WARRANTY CLAIMS

General Conditions of Warranty and Definition of Terms

All Warranty Conditions stated here under determine Warranty Coverage and Warranty Claim Procedure. Conditions of Warranty and Warranty Claims are governed by Act No. 89/2012 Coll. Civil Code, and Act No. 634/1992 Coll., Consumer Protection, as amended, also in cases that are not specified by these Warranty rules.

The seller is SEVEN SPORT s.r.o. with its registered office in Kutnohorská 531, Štěrboholy Retail Park, 109 00, Praha 10, ČR, Company Registration Number: 26847264, registered in the Trade Register at Regional Court in Prague, Section C, Insert No. 116888.

According to valid legal regulations it depends whether the Buyer is the End Customer or not.

"The Buyer who is the End Customer" or simply the "End Customer" is the legal entity that does not conclude and execute the Contract in order to run or promote his own trade or business activities.

"The Buyer who is not the End Customer" is a Businessman that buys Goods or uses services for the purpose of using the Goods or services for his own business activities. The Buyer conforms to the General Purchase Agreement and business conditions.

These Conditions of Warranty and Warranty Claims are an integral part of every Purchase Agreement made between the Seller and the Buyer. All Warranty Conditions are valid and binding, unless otherwise specified in the Purchase Agreement, in the Amendment to this Contract or in another written agreement.

Warranty Conditions

Warranty Period

The Seller provides the Buyer a 24 months Warranty for Goods Quality, unless otherwise specified in the Certificate of Warranty, Invoice, Bill of Delivery or other documents related to the Goods. The legal warranty period provided to the Consumer is not affected.

By the Warranty for Goods Quality, the Seller guarantees that the delivered Goods shall be, for a certain period of time, suitable for regular or contracted use, and that the Goods shall maintain its regular or contracted features.

Batteries

6-month battery warranty – we guarantee that battery's nominal capacity does not fall below 70% of its total capacity within 6 months of the product's sale.

The Warranty does not cover defects resulting from (if applicable):

- User's fault, i.e. product damage caused by unqualified repair work, improper assembly, insufficient insertion of seat post into frame, insufficient tightening of pedals and cranks
- Improper maintenance
- Mechanical damages
- Regular use (e.g. wearing out of rubber and plastic parts, moving mechanisms, joints, wear of brake pads/blocks, chain, tires, cassette/multi wheel etc.)
- Unavoidable event, natural disaster

- Adjustments made by unqualified person
- Improper maintenance, improper placement, damages caused by low or high temperature, water, inappropriate pressure, shocks, intentional changes in design or construction etc.

Warranty Claim Procedure

The Buyer is obliged to check the Goods delivered by the Seller immediately after taking the responsibility for the Goods and its damages, i.e. immediately after its delivery. The Buyer must check the Goods so that he discovers all the defects that can be discovered by such check.

When making a Warranty Claim the Buyer is obliged, on request of the Seller, to prove the purchase and validity of the claim by the Invoice or Bill of Delivery that includes the product's serial number, or eventually by the documents without the serial number. If the Buyer does not prove the validity of the Warranty Claim by these documents, the Seller has the right to reject the Warranty Claim.

If the Buyer gives notice of a defect that is not covered by the Warranty (e.g. in the case that the Warranty Conditions were not fulfilled or in the case of reporting the defect by mistake etc.), the Seller is eligible to require a compensation for all the costs arising from the repair. The cost shall be calculated according to the valid price list of services and transport costs.

If the Seller finds out (by testing) that the product is not damaged, the Warranty Claim is not accepted. The Seller reserves the right to claim a compensation for costs arising from the false Warranty Claim.

In case the Buyer makes a claim about the Goods that is legally covered by the Warranty provided by the Seller, the Seller shall fix the reported defects by means of repair or by the exchange of the damaged part or product for a new one. Based on the agreement of the Buyer, the Seller has the right to exchange the defected Goods for a fully compatible Goods of the same or better technical characteristics. The Seller is entitled to choose the form of the Warranty Claim Procedures described in this paragraph.

The Seller shall settle the Warranty Claim within 30 days after the delivery of the defective Goods, unless a longer period has been agreed upon. The day when the repaired or exchanged Goods is handed over to the Buyer is considered to be the day of the Warranty Claim settlement. When the Seller is not able to settle the Warranty Claim within the agreed period due to the specific nature of the Goods defect, he and the Buyer shall make an agreement about an alternative solution. In case such agreement is not made, the Seller is obliged to provide the Buyer with a financial compensation in the form of a refund.

CZ SEVEN SPORT s.r.o.

Registered Office: Kutnohorská 531, Štěřboholý Retail Park,
109 00, Praha 10, ČR

Headquarters: Dělnická 957, Vítkov, 749 01
Warranty & Service: Čermenská 486, Vítkov 749 01

CRN: 26847264
VAT ID: CZ26847264

Phone: +420 556 300 970
E-mail: eshop@insportline.cz
reklamace@insportline.cz
servis@insportline.cz

Web: www.inSPORTline.cz

SK Stores inSPORTline SK, s.r.o.

Headquarters, warranty & service center: Električná 6471,
Trenčín 911 01, SK

CRN: 46259317
VAT ID: SK2023299729

Phone: +421(0) 917 700 098
E-mail: objednavky@insportline.sk
reklamacie@insportline.sk
servis@insportline.sk

Web: www.inSPORTline.sk

About shipping

