



USER MANUAL – EN

IN 23796 Billiard table 3in1 inSPORTline Residento



CONTENTS

SAFETY INSTRUCTIONS..... 3

PARTS LIST 3

ASSEMBLY 4

TABLE LEVELING..... 7

NET ATTACHMENT 8

MAINTENANCE 8

RULES..... 8

 TABLE TENNIS 8

 BILLIARD 9

ENVIRONMENT PROTECTION 10





TERMS AND CONDITIONS OF WARRANTY, WARRANTY CLAIMS **Chyba! Záložka není definována.**

SAFETY INSTRUCTIONS

- Read the manual before use and keep it for future reference.
- Assembly must be performed by at least two adults.
- Keep out of reach of children, children can inhale small parts during assembly and use. There is a risk of suffocation.
- Do not repair or modify the product.
- Use only for the purpose for which the device was assembled.
- Do not leave children or pets unattended around the table.
- For indoor use only.
- Do not sit or climb on the table.
- Do not pull the stand upside down, always lift it to carry it.
- Do not place drinks or food on the playing fields of billiard and table tennis.
- Use the table only if it is properly aligned.

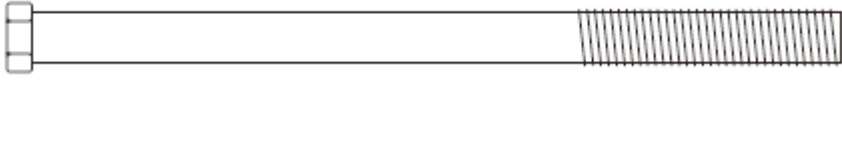
PARTS LIST

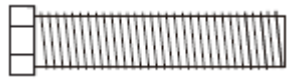
HARDWARE





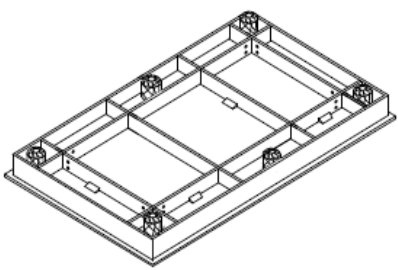
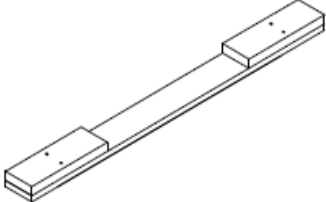
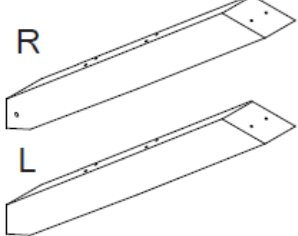

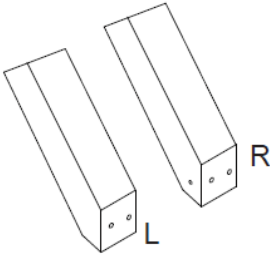
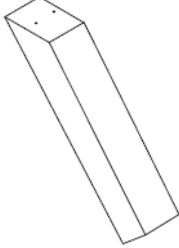
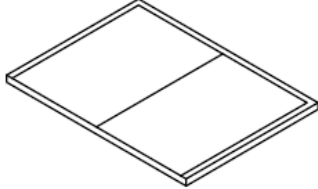
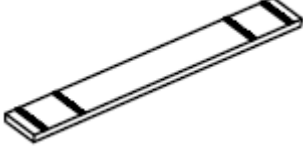
		
H1 – 8 mm x 130 mm hexagon bolts 8x		T1 - wrench – 1x
		
H2 - 8 mm x 40 mm hexagon bolts – 20x	H3 – M8 flat washer – 28x	H4 – M8 lock washer– 28x

PARTS LIST

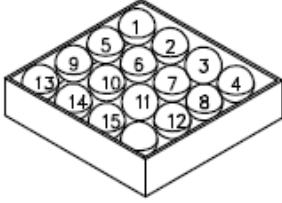
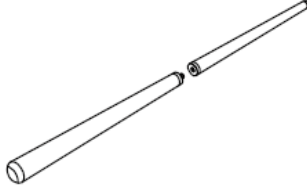
		
P1 – main frame – 1x	P2 – base – 2x	P3 – middle legs – 2x

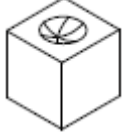
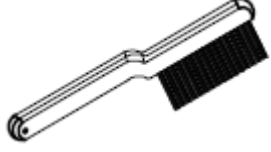
		
P4 – top legs – 2x	P5 – bottom legs – 2x	P6 – table tennis desk – 2x
		
P7 – table tennis desk support – 1x		

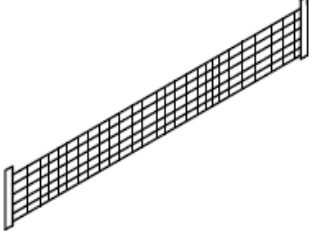
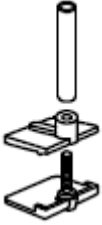
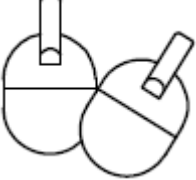
ACCESSORIES

		
A1 – billiard set – 1x	A2 – cue – 2x	A3 – triangle – 1x
		
A4 – chalk – 2x	A5 – brush – 1x	A6 – table shim – 4x
		
A7 – table tennis net – 1x	A8 – net mounting – 2x	A9 – table tennis bats – 2x
		
A10 – table tennis balls – 2x		

ASSEMBLY

- Assembly may be performed by at least two adults.
- Some parts may be slightly modified in the drawing for better visibility.

- During assembly, we recommend tightening the screws by hand first.
- Prior to assembly, make sure that no parts are missing.
- Assembly must be done with caution.

STEP 1

Part	Name	Qty.	Part	Name	Qty.
P1	main frame	1	H2	hexagon bolts	12
P3	middle legs	2	H3	flat washer	12
P4	top legs	2	H4	lock washer	12

Attach the upper leg of P4 and the middle leg of P3 to the main frame using bolts H2, flat washers H3 and lock washers H4.

Do not tighten the screws until the whole leg has been completed.

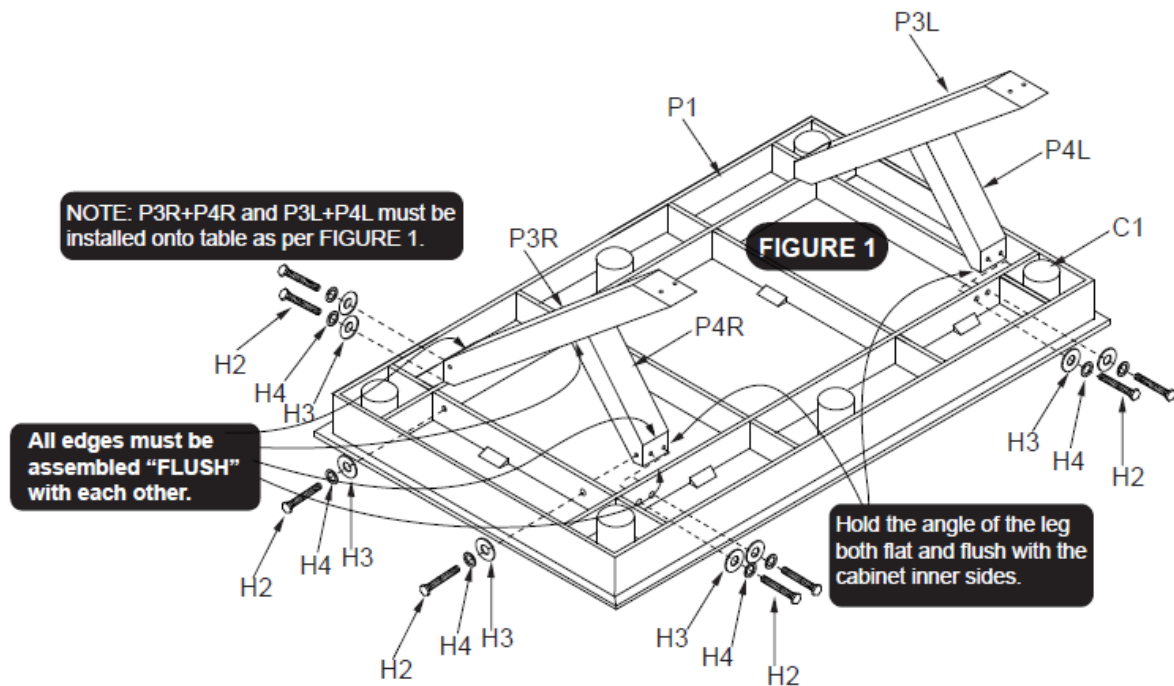

STEP 2

Part	Name	Qty.	Part	Name	Qty.
P5	bottom legs	2	H3	flat washer	8
H1	hexagon bolts	8	H4	lock washer	8

Attach the upper legs P4 to the middle legs P3 using bolts H1, flat washers H3 and lock washers H4.

Attach the lower feet P5 to the middle feet P3 using bolts H1, flat washers H3 and lock washers H4.

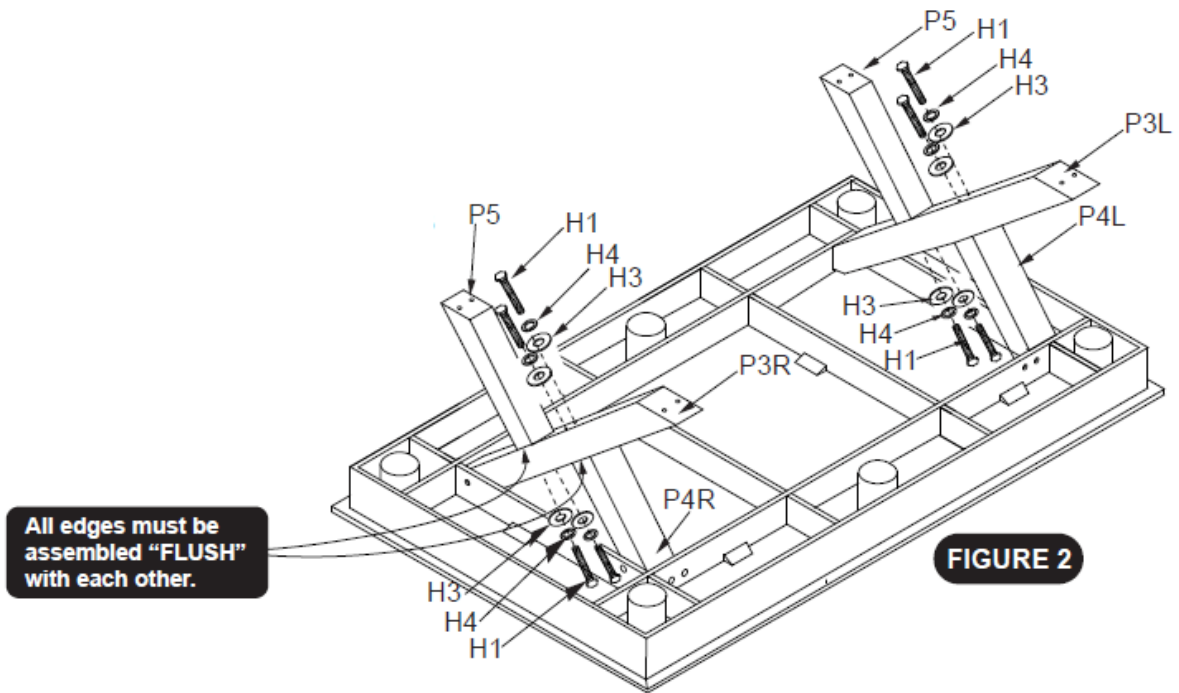

STEP 3

Part	Name	Qty.	Part	Name	Qty.
P2	base	2	H3	flat washer	8
H2	hexagon bolts	8	H4	lock washer	8

Attach the bases P2 to the middle legs P3 and the lower legs P5 using bolts H2, flat washers H3 and lock washers H4.

Tighten all screws.

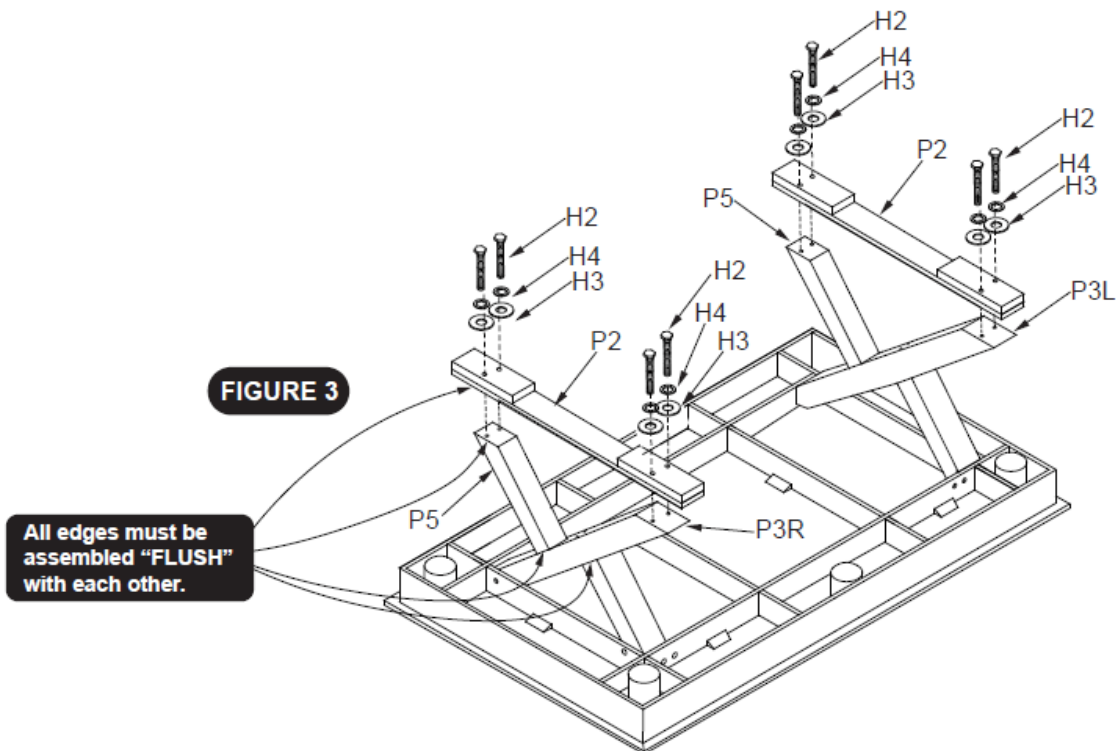

WARNING:

You need 4 or more people for the next step. While rotating the table, carefully rotate the table so that you do not place it on the edge of your foot.

Do not hold the table by the legs, but by the main structure.

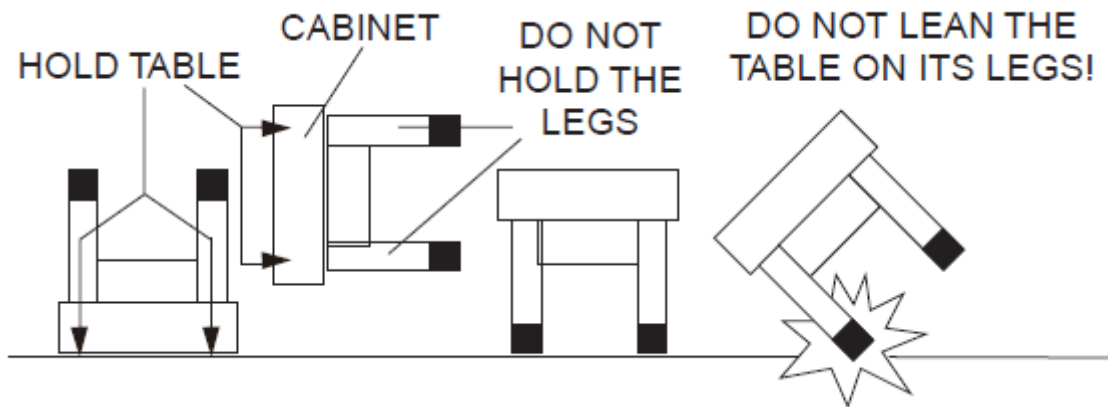
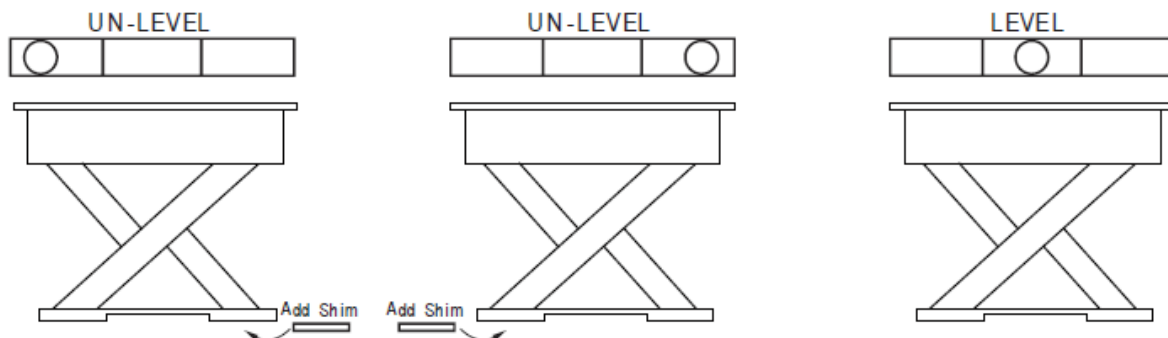

TABLE LEVELING

After table assembly and placing it where it will be used, it is necessary to level the table.

You can level the table using the A6 leveling plates under the bases.

Depending on the surface, it can take up to 24 hours until the surface under the table is stable and not moving, check the table after 24 hours.



NET ATTACHMENT

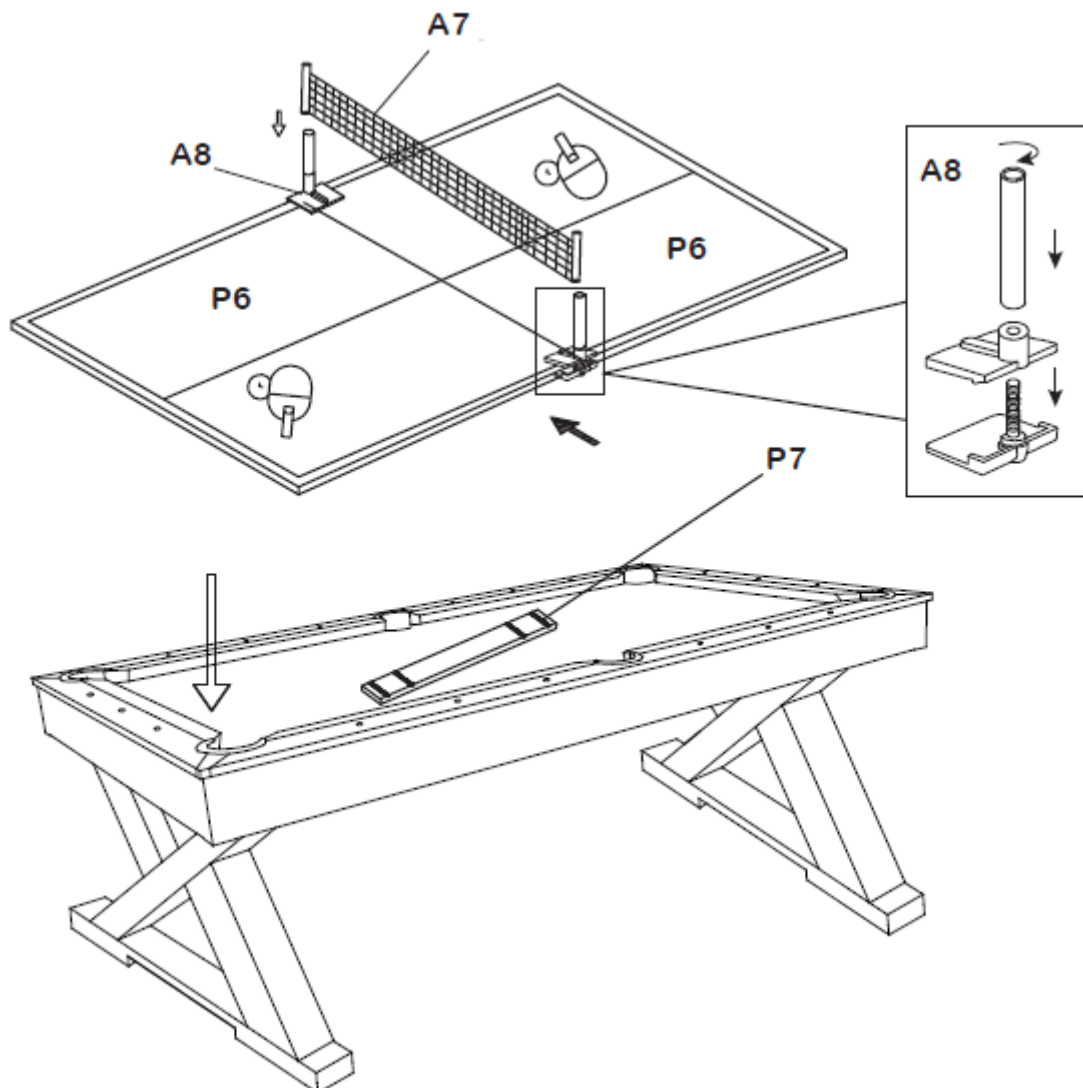

MAINTENANCE

Clean the outside of dirt with dust cleaners and polishes.

Clean the fabric / textile part ONLY with the provided brush.

RULES

TABLE TENNIS

- The game begins with serving. Throw a coin to determine a player that will serve first.
- The ball is served from the open palm, so the opponent can see the ball during the serve, e.g. may not be covered by the hand or other part of the body of the player. It is superimposed above the level of the table and the ball must be played at least 16 cm above the table top.
- The ball must first be bounced off the table half of the handler, then skip the mesh and bounce off the opponent's half of the table. If the ball touches the net when the ball is hit, the serve is repeated.

- Players alternate with the two played balls every time, until the 10:10. They then alternate each time after a single administration.
- The ball can be played by any part of the racket or hand holding it (up to the wrist height) and must be bounced off the opponent's half of the table.
- During a game, the ball may touch the net. When played away from the table, he does not have to fly directly over the mesh on his opponent's half, but he must always reach a height of at least 16 cm above the table top.
- **You get the point if the opponent did not bounce the ball as he had, e.g. did not hit the ball, the ball touched his half more than once, the opponent bounced the ball so that it first bounced off his desk or the table did not touch at all. The opponent also must not touch the playing table with any part of the body, except for the hand holding otherwise the opponent gets a point.**
- **One game consists of an odd number of sets at which players have agreed before the game. It is usually 3 to 5 sets.**
- **One set consists of several serving and ends when one of the players has earned 11 points. If you score at 10:10, it is played until the players is winning by two 2 points. It is possible that the final score will be, for example, 13:15 or 19:17, etc.**
- **Players change sides at the beginning of each set and rotate at the opening of each new game.**

BILLIARD

- **The winner of the game is the player who first shot all the balls of the type he has chosen into the playing holes and eventually puts a black ball in the correct hole.**
- **Players just push white ball with cue stick to collide with the other balls and direct them to one of the holes.**
- **Players change whenever someone fails to place at least one ball in their pocket or when a player makes a foul.**
- **A black ball is shot only after all balls of one type have been scored. If a black ball is in the hole before any player's balls, the player who shot it into the hole lost.**
- **Stroke = strike with a cue to a white ball, Rise = a series of strokes with a stroke where the player failed to play the ball in the hole, Foul = forbidden play.**
- **Foul is punished by ending the player's round. The opponent then plays 2x, e.g. has 2 attempts to first score a ball in the hole. The foul is considered:**
 - a) **Stroke, in which the white ball does not touch any other balls.**
 - b) **Stroke, in which a white ball falls into the hole. The opponent then plays from the front line. The white ball must first touch the ball that lies in the second half of the table.**
 - c) **Stroke, in which the white ball touches the opponent's balls or black ball first.**
 - d) **Stroke, in which the opponent's ball falls into the hole.**
 - e) **Stroke at which the ball falls out of the table. In that case, the ball is placed at the back.**
 - f) **Touching the balls with hands, other parts of the body or clothing, touching the ball with other parts of the cues than the "tip", touching a ball other than white.**
 - g) **Stroke with the cue into a non-white ball.**
- **Opening break shot: The balls are built in a basic position. (Picture below). One player will make a stroke in which he tries to place any ball (except black) in any hole without making a foul. If he succeeds in doing so, he plays the ball with the same type of ball in the hole for the rest of the game. The opponent plays the second color. If he does not**

manage to place a ball in the hole, the opponent plays and tries to do the same. Continue until you determine which player is playing with which color, the players play with a white ball on any ball on the table except black.

- **Playing:** After the ball is assigned to the player, the players alternate in the strokes. Each of them can play if he does not make a shot in which he will not be able to play one of his balls in the holes or until he makes a foul.
- **Finishing the game:** After placing all your balls, the player's task is to place a black ball in the hole of the opposite hole in which he placed his last ball. If he succeeds, he wins. If the black ball is placed in another pocket, it means losing it. Likewise, it means a loss when, when he plays a black ball in the right hole and makes a foul (e.g. play more balls to the hole). If a player who placed all his balls in the holes as the other, places the last ball in the same hole as his opponent, he tries to place the black ball in the same hole in which he placed his last ball.

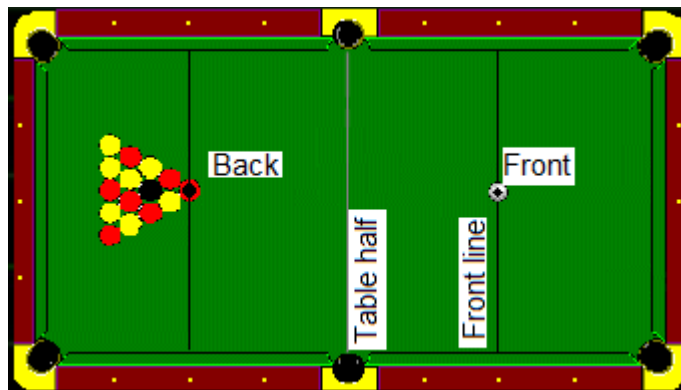

ENVIRONMENT PROTECTION

After the product lifespan expired or if the possible repairing is uneconomic, dispose it according to the local laws and environmentally friendly in the nearest scrapyards.

By proper disposal you will protect the environment and natural sources. Moreover, you can help protect human health. If you are not sure in correct disposing, ask local authorities to avoid law violation or sanctions.

Don't put the batteries among house waste but hand them in to the recycling place.

SevenSport s.r.o. reserves the right to make any changes and improvements to its product without prior notice. Visit our website www.insportline.eu where you will find the latest version of the manual.

TERMS AND CONDITIONS OF WARRANTY, WARRANTY CLAIMS

General Conditions of Warranty and Definition of Terms

All Warranty Conditions stated here under determine Warranty Coverage and Warranty Claim Procedure. Conditions of Warranty and Warranty Claims are governed by Act No. 89/2012 Coll. Civil Code, and Act No. 634/1992 Coll., Consumer Protection, as amended, also in cases that are not specified by these Warranty rules.

The seller is SEVEN SPORT s.r.o. with its registered office in Kutnohorská 531, Štěrboholy Retail Park, 109 00, Praha 10, ČR, Company Registration Number: 26847264, registered in the Trade Register at Regional Court in Prague, Section C, Insert No. 116888.

According to valid legal regulations it depends whether the Buyer is the End Customer or not.

“The Buyer who is the End Customer” or simply the “End Customer” is the legal entity that does not conclude and execute the Contract in order to run or promote his own trade or business activities.

“The Buyer who is not the End Customer” is a Businessman that buys Goods or uses services for the purpose of using the Goods or services for his own business activities. The Buyer conforms to the General Purchase Agreement and business conditions.

These Conditions of Warranty and Warranty Claims are an integral part of every Purchase Agreement made between the Seller and the Buyer. All Warranty Conditions are valid and binding, unless otherwise specified in the Purchase Agreement, in the Amendment to this Contract or in another written agreement.

Warranty Conditions

Warranty Period

The Seller provides the Buyer a 24 months Warranty for Goods Quality, unless otherwise specified in the Certificate of Warranty, Invoice, Bill of Delivery or other documents related to the Goods. The legal warranty period provided to the Consumer is not affected.

By the Warranty for Goods Quality, the Seller guarantees that the delivered Goods shall be, for a certain period of time, suitable for regular or contracted use, and that the Goods shall maintain its regular or contracted features.

Batteries

6-month battery warranty – we guarantee that battery's nominal capacity does not fall below 70% of its total capacity within 6 months of the product's sale.

The Warranty does not cover defects resulting from (if applicable):

- User's fault, i.e. product damage caused by unqualified repair work, improper assembly, insufficient insertion of seat post into frame, insufficient tightening of pedals and cranks
- Improper maintenance
- Mechanical damages
- Regular use (e.g. wearing out of rubber and plastic parts, moving mechanisms, joints, wear of brake pads/blocks, chain, tires, cassette/multi wheel etc.)
- Unavoidable event, natural disaster
- Adjustments made by unqualified person
- Improper maintenance, improper placement, damages caused by low or high temperature, water, inappropriate pressure, shocks, intentional changes in design or construction etc.

Warranty Claim Procedure

The Buyer is obliged to check the Goods delivered by the Seller immediately after taking the responsibility for the Goods and its damages, i.e. immediately after its delivery. The Buyer must check the Goods so that he discovers all the defects that can be discovered by such check.

When making a Warranty Claim the Buyer is obliged, on request of the Seller, to prove the purchase and validity of the claim by the Invoice or Bill of Delivery that includes the product's serial number, or eventually by the documents without the serial number. If the Buyer does not prove the validity of the Warranty Claim by these documents, the Seller has the right to reject the Warranty Claim.

If the Buyer gives notice of a defect that is not covered by the Warranty (e.g. in the case that the Warranty Conditions were not fulfilled or in the case of reporting the defect by mistake etc.), the Seller is eligible to require a compensation for all the costs arising from the repair. The cost shall be calculated according to the valid price list of services and transport costs.

If the Seller finds out (by testing) that the product is not damaged, the Warranty Claim is not accepted. The Seller reserves the right to claim a compensation for costs arising from the false Warranty Claim.

In case the Buyer makes a claim about the Goods that is legally covered by the Warranty provided by the Seller, the Seller shall fix the reported defects by means of repair or by the exchange of the damaged part or product for a new one. Based on the agreement of the Buyer, the Seller has the right

to exchange the defected Goods for a fully compatible Goods of the same or better technical characteristics. The Seller is entitled to choose the form of the Warranty Claim Procedures described in this paragraph.

The Seller shall settle the Warranty Claim within 30 days after the delivery of the defective Goods, unless a longer period has been agreed upon. The day when the repaired or exchanged Goods is handed over to the Buyer is considered to be the day of the Warranty Claim settlement. When the Seller is not able to settle the Warranty Claim within the agreed period due to the specific nature of the Goods defect, he and the Buyer shall make an agreement about an alternative solution. In case such agreement is not made, the Seller is obliged to provide the Buyer with a financial compensation in the form of a refund.

CZ
SEVEN SPORT s.r.o.

Registered Office: Kutnohorská 531, Štěrboholy Retail Park,
109 00, Praha 10, ČR

Headquarters: Dělnická 957, Vítkov, 749 01
Warranty & Service: Čermenská 486, Vítkov 749 01

CRN: 26847264
VAT ID: CZ26847264

Phone: +420 556 300 970
E-mail: eshop@insportline.cz
reklamace@insportline.cz
servis@insportline.cz

Web: www.inSPORTline.cz

SK
Stores inSPORTline SK, s.r.o.

Headquarters, warranty & service center: Električná 6471,
Trenčín 911 01, SK

CRN: 46259317
VAT ID: SK2023299729

Phone: +421(0) 917 700 098
E-mail: objednavky@insportline.sk
reklamacie@insportline.sk
servis@insportline.sk

Web: www.inSPORTline.sk

About shipping

