

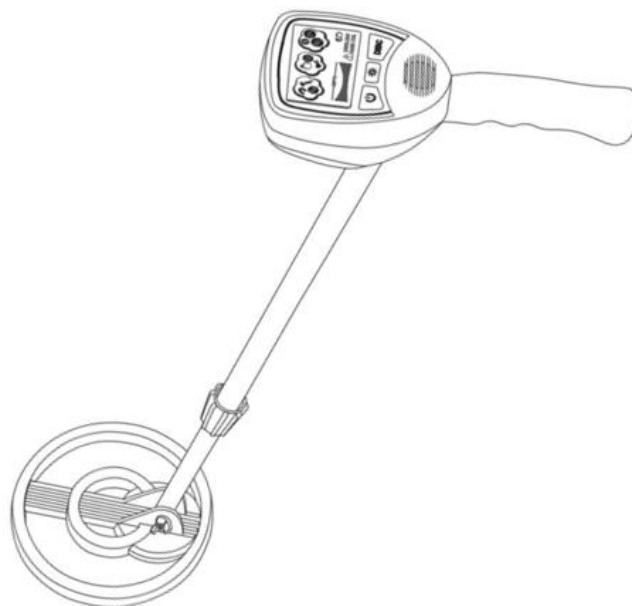

**USER MANUAL – EN**

**IN 23370 Kid's metal detector inSPORTline Goldino**



# CONTENTS

SAFETY INSTRUCTIONS.....	3
USE .....	3
BATTERY.....	3
FUNCTIONS AND INDICATORS .....	4
SOUND SIGNALS .....	6
ADAPTIVE SOUND SIGNALS.....	6
USE .....	6
QUICK TEST.....	6
TURNING ON AND OFF .....	7
DISCRIMINATION .....	7
HOW TO MOVE THE COIL.....	7
FACTORS AFFECTING DETECTION .....	7
MAINTENANCE .....	8
ENVIRONMENT PROTECTION .....	8
TERMS AND CONDITIONS OF WARRANTY, WARRANTY CLAIMS.....	8

## SAFETY INSTRUCTIONS

Read the manual carefully before use and assembly and keep it for future reference.

Always check local laws and regulations.

Never use the detector in historical or archaeological sites unless you are authorized to do so.

Never leave dug holes unattended, always bury them after finding the object.

Respect private property and do not enter private property without the owner's consent.

For outdoor use only.

The control panel is powered by 2x AA batteries.

## USE

### LENGTH ADJUSTMENT

Loosen the nut on the bar clockwise.

Adjust the length of the bar and then slightly tighten with a nut counterclockwise.

The coil should be 1 - 5 cm away from ground and parallel to the ground. Once you have set the exact height, secure with the nut counterclockwise. Do not overtighten the nut.

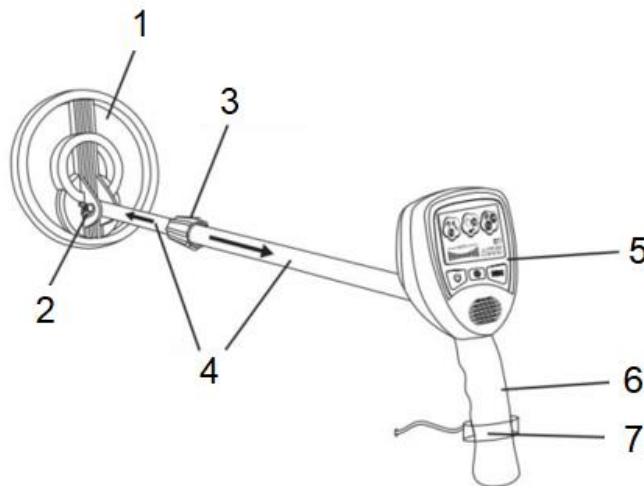

1. Coil
2. Coil bolt
3. Nut
4. Bar

5. Control panel
6. Handle
7. Strap

### BATTERY

The control panel is powered by 2x AA batteries.

1. Open the panel in the direction of the arrow.
2. Insert the batteries with the correct polarities. Close the cover.

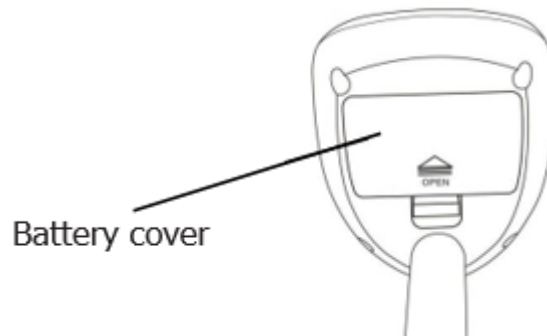

**WARNING:**

- If you are replacing the batteries, replace both.
- If you do not plan to use the detector, remove the batteries.
- Replace the batteries when the battery indicator shows low battery.

**FUNCTIONS AND INDICATORS**

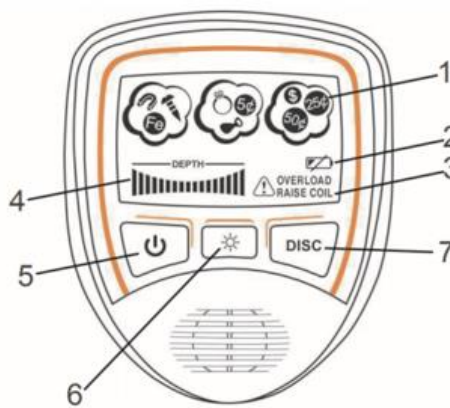

**1. Composition of the object**

Ferrous:

Nails, screws, larger metal objects such as horseshoes.

The detector announces the object in a deep tone and

displays



Non-ferrous metal, low conductor:

US nickel coins, rings, small jewelry, foil, caps, etc.

The detector announces the object in a middle tone and

displays



Non-ferrous metal, high conductor:

Copper and silver coins.

The detector announces the object in a high tone and

displays 



## 2. Battery indicator

If the battery is low, the 1 icon is displayed. At that time, there is a maximum of one hour of operation left. If the battery status is close to turning off the device, the 2 icon will flash.



## 3. Overload

If the coil detects a large metal object or highly magnetic ground, the detector will be overloaded. "OVERLOAD RAISE COIL" appears on the display. The detector also alerts you with an audible signal. Overload will not damage the detector, but will not work under such conditions. If this happens, lift the coil or move to another location.

## 4. DEPTH

Coin-sized objects are detected to a depth up to 10 cm. The detector displays the depth using segments. The detector is calibrated for coin-sized items.



**1 segment**  
**0 – 5 cm depth**

**2 segments**  
**5 – 10 cm depth**

**3 segment**  
**10 + cm depth**

## 5. Power switch

Press and hold the power button to turn it on or off

## 6. Backlight

Press the button to turn on / off the backlight

## 7. Discrimination settings

Once turned on, the detector detects all metals. You can use the DISC button to set metals that you do not want to detect.

Discrimination for ferrous metal objects



Discrimination for non-ferrous objects with low conductivity



Discrimination for non-ferrous objects with high conductivity

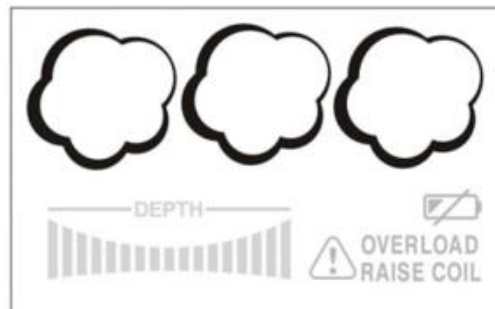

## SOUND SIGNALS

The detector emits deep, medium and high sound signals, depending on the metal found.

Low tone: Ferrous metal object

Midtone: Non-ferrous metal, low conductivity

High tone: Non-ferrous metal, highly conductive

## ADAPTIVE SOUND SIGNALS

The detector emits sounds according to the distance to the object. The closer the coil is to a metal object, the louder the sound it will make and vice versa. Objects are detected even when the sound is weak, determining only the approximate depth of the object.

## USE

### QUICK TEST

For a quick test of the detector, you will need a nail, nickel, gold jewelry and a quarter, or metals with similar properties.

Aim the coil away from floors, walls and metal objects. One person will hold the detector and the other person will move objects in front of the coil.

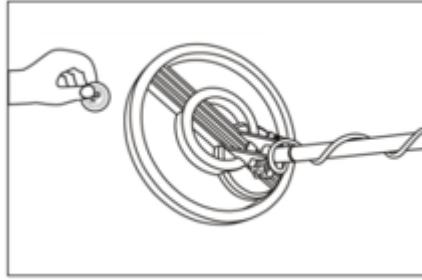

## TURNING ON AND OFF

Press and hold  button to start. During the test, notice that the sound is loudest in the middle of the coil and gradually fades as it begins to move away from the coil. The "DEPTH INDICATOR" depth indicator shows the distance from the coil. If you exceed the maximum distance, the detector will not detect metal.

To turn off the detector, press and hold the  button.

## DISCRIMINATION

Use the "DISC" button to set an exception for which metals you do not want to detect. The explanations are described in the FUNCTIONS chapter. Set the discrimination according to the object you are looking for. Some soils may be rich in a particular metal or may be contaminated with that metal.

## HOW TO MOVE THE COIL

Move the coil horizontally to the ground, ideally at even distance. The movement of the coil should be slow and even. If the coil does not move, the detector is not able to detect metal. When the movement is complete, try not to raise the spool but to continue the movement smoothly.

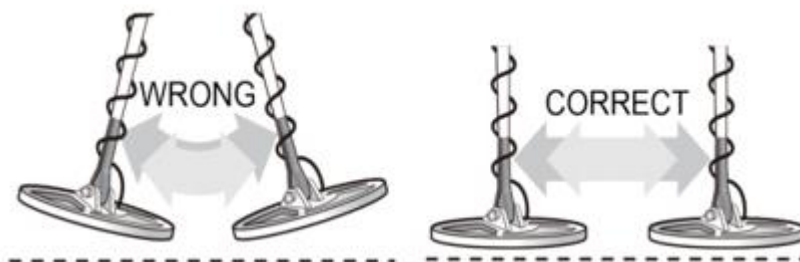

## FACTORS AFFECTING DETECTION

- Angle of a hidden object.
- Depth of the subject.
- Oxidation level.
- Item size.
- Electromagnetic influences of the environment.

If you move the detector in soils rich in metals or wet sand, the coil will constantly announce objects even if there are none. In this case, you must set a discrimination. Detection can also be affected by items that you use for digging. Therefore, keep them away from the metal detector. Also, do not use

the detector indoors. There is a great influence of electromagnetic waves, metals, etc in buildings. The coil is waterproof, but the control panel is not waterproof.

## **MAINTENANCE**

- Protect the detector against impacts and falls.
- Do not use the detector in extreme conditions such as high or low temperatures or bad weather.
- Clean the detector with a damp cloth. Do not use aggressive cleaning agents.
- Store the detector in a dry, clean, dust-free, and shady place.

## **ENVIRONMENT PROTECTION**

After the product lifespan expired or if the possible repairing is uneconomic, dispose it according to the local laws and environmentally friendly in the nearest scrapyard.

By proper disposal you will protect the environment and natural sources. Moreover, you can help protect human health. If you are not sure in correct disposing, ask local authorities to avoid law violation or sanctions.

Don't put the batteries among house waste but hand them in to the recycling place.

## **TERMS AND CONDITIONS OF WARRANTY, WARRANTY CLAIMS**

### **General Conditions of Warranty and Definition of Terms**

All Warranty Conditions stated here under determine Warranty Coverage and Warranty Claim Procedure. Conditions of Warranty and Warranty Claims are governed by Act No. 89/2012 Coll. Civil Code, and Act No. 634/1992 Coll., Consumer Protection, as amended, also in cases that are not specified by these Warranty rules.

The seller is SEVEN SPORT s.r.o. with its registered office in Strakonická street 1151/2c, Prague 150 00, Company Registration Number: 26847264, registered in the Trade Register at Regional Court in Prague, Section C, Insert No. 116888.

According to valid legal regulations it depends whether the Buyer is the End Customer or not.

“The Buyer who is the End Customer” or simply the “End Customer” is the legal entity that does not conclude and execute the Contract in order to run or promote his own trade or business activities.

“The Buyer who is not the End Customer” is a Businessman that buys Goods or uses services for the purpose of using the Goods or services for his own business activities. The Buyer conforms to the General Purchase Agreement and business conditions.

These Conditions of Warranty and Warranty Claims are an integral part of every Purchase Agreement made between the Seller and the Buyer. All Warranty Conditions are valid and binding, unless otherwise specified in the Purchase Agreement, in the Amendment to this Contract or in another written agreement.

### **Warranty Conditions**

#### **Warranty Period**

The Seller provides the Buyer a 24 months Warranty for Goods Quality, unless otherwise specified in the Certificate of Warranty, Invoice, Bill of Delivery or other documents related to the Goods. The legal warranty period provided to the Consumer is not affected.

By the Warranty for Goods Quality, the Seller guarantees that the delivered Goods shall be, for a certain period of time, suitable for regular or contracted use, and that the Goods shall maintain its regular or contracted features.

**The Warranty does not cover defects resulting from (if applicable):**



- User's fault, i.e. product damage caused by unqualified repair work, improper assembly, insufficient insertion of seat post into frame, insufficient tightening of pedals and cranks
- Improper maintenance
- Mechanical damages
- Regular use (e.g. wearing out of rubber and plastic parts, moving mechanisms, joints, wear of brake pads/blocks, chain, tires, cassette/multi wheel etc.)
- Unavoidable event, natural disaster
- Adjustments made by unqualified person
- Improper maintenance, improper placement, damages caused by low or high temperature, water, inappropriate pressure, shocks, intentional changes in design or construction etc.

### **Warranty Claim Procedure**

The Buyer is obliged to check the Goods delivered by the Seller immediately after taking the responsibility for the Goods and its damages, i.e. immediately after its delivery. The Buyer must check the Goods so that he discovers all the defects that can be discovered by such check.

When making a Warranty Claim the Buyer is obliged, on request of the Seller, to prove the purchase and validity of the claim by the Invoice or Bill of Delivery that includes the product's serial number, or eventually by the documents without the serial number. If the Buyer does not prove the validity of the Warranty Claim by these documents, the Seller has the right to reject the Warranty Claim.

If the Buyer gives notice of a defect that is not covered by the Warranty (e.g. in the case that the Warranty Conditions were not fulfilled or in the case of reporting the defect by mistake etc.), the Seller is eligible to require a compensation for all the costs arising from the repair. The cost shall be calculated according to the valid price list of services and transport costs.

If the Seller finds out (by testing) that the product is not damaged, the Warranty Claim is not accepted. The Seller reserves the right to claim a compensation for costs arising from the false Warranty Claim.

In case the Buyer makes a claim about the Goods that is legally covered by the Warranty provided by the Seller, the Seller shall fix the reported defects by means of repair or by the exchange of the damaged part or product for a new one. Based on the agreement of the Buyer, the Seller has the right to exchange the defected Goods for a fully compatible Goods of the same or better technical characteristics. The Seller is entitled to choose the form of the Warranty Claim Procedures described in this paragraph.

The Seller shall settle the Warranty Claim within 30 days after the delivery of the defective Goods, unless a longer period has been agreed upon. The day when the repaired or exchanged Goods is handed over to the Buyer is considered to be the day of the Warranty Claim settlement. When the Seller is not able to settle the Warranty Claim within the agreed period due to the specific nature of the Goods defect, he and the Buyer shall make an agreement about an alternative solution. In case such agreement is not made, the Seller is obliged to provide the Buyer with a financial compensation in the form of a refund.

#### **CZ SEVEN SPORT s.r.o.**

Registered Office: Strakonická 1151/2c, Praha 5, 150 00, ČR  
Headquarters: Dělnická 957, Vítkov, 749 01  
Warranty & Service: Čermenská 486, Vítkov 749 01

CRN: 26847264  
VAT ID: CZ26847264

Phone: +420 556 300 970  
E-mail: eshop@insportline.cz  
reklamace@insportline.cz  
servis@insportline.cz

Web: www.inSPORTline.cz

#### **SK inSPORTline s.r.o.**

Headquarters, warranty & service center: Električná 6471, Trenčín 911 01, SK

CRN: 36311723

VAT ID: SK2020177082

Phone: +421(0)326 526 701

E-mail: [objednavky@insportline.sk](mailto:objednavky@insportline.sk)

[reklamacie@insportline.sk](mailto:reklamacie@insportline.sk)

[servis@insportline.sk](mailto:servis@insportline.sk)

Web: [www.inSPORTline.sk](http://www.inSPORTline.sk)