

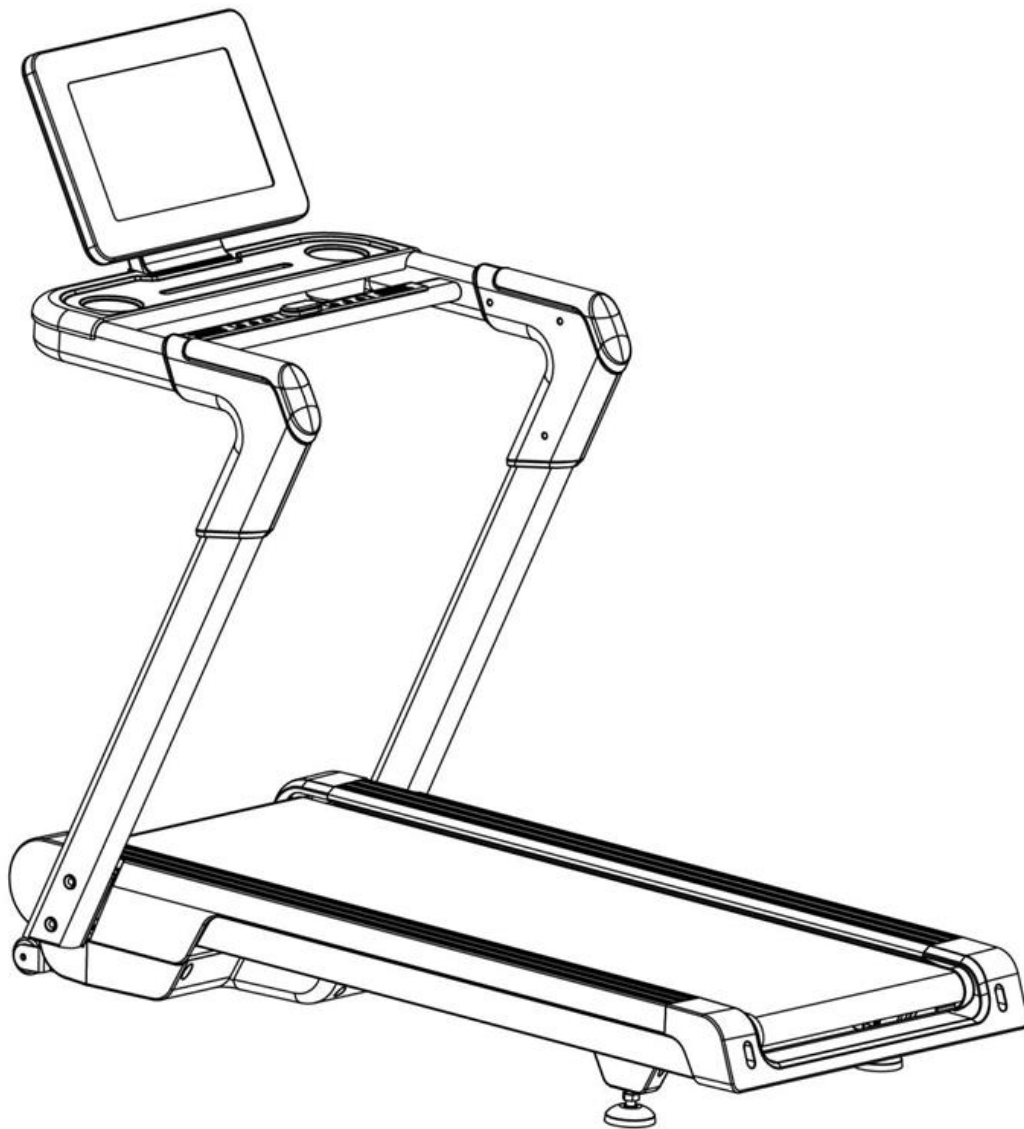

USER MANUAL – EN

IN 21321 Treadmill inSPORTline inCondi T420i



CONTENTS

- SAFETY INSTRUCTIONS..... 3
- PACKAGE 4
 - ASSEMBLY 5
- MOVING 10
- CONSOLE 11
- MAINTENANCE GUIDE 13
 - ADJUSTING THE RUNNING BELT..... 13
 - LUBRICATING THE TREADMILL 14
- DIAGRAM 15
- PARTS LIST 17
 - SPARE PARTS (NOT INCLUDED) 18
- ENVIRONMENT PROTECTION 18
- TERMS AND CONDITIONS OF WARRANTY, WARRANTY CLAIMS..... 18

SAFETY INSTRUCTIONS

- Read the manual carefully and keep it for future reference.
- Always clip the safety key to your clothes or belt before starting exercising.
- Move naturally, forward. Do not look on your feet. Only for one person can use the product on the same time.
- Speed increase gradually, not instantly.
- In case of danger, press the stop button or pull out the safety key.
- Leave the device after it stopes moving.
- Follow the assembly instructions. Assembly can be done by adult person.
- Keep away from kids and pets. Do not leave kids and pets unattended near the treadmill. Treadmill is for adults only.
- Before starting any exercise, program ask your physician. It is important if you have heath issues or ongoing treatment or have high blood pressure.
- Regularly check all bolts and nuts. They must be tightened properly. Regularly check the treadmill for damage or signs of wear. Do not use damaged or wear treadmill.
- Regularly check the treadmill for signs of wear or damage. If any sharp edge appears stop using the treadmill.
- Please the treadmill on flat, dry and cleat surface. Keep safety distance of at least 0.6 m around the treadmill. Do not use in humid areas. Do not place the treadmill on thick carpet.
- If the power cable is damaged do not use the device. Buy new one in authorized shop.
- Protect the treadmill from humidity and water.
- Place the treadmill not to cover socket.
- Do not use aerosol sprays in the area around treadmill.
- If the treadmill is running, do not remove the protective cover. If you need to remove the protective cover during maintenance, unplug the treadmill from socket.
- Always wear sport clothes. Do not wear loose clothes that can get stuck. Always wear sport boots.
- Do not turn on the treadmill if you are standing on it. There is a delay when you turn on the treadmill. Before starting the treadmill stand on the side.
- Do not exercise 40 min after eating food.
- Always do warm ups before exercise.
- Do not place foreign object to ventilation or sockets.
- Maintenance should be done only according to the manual, to prolong the lifespan.
- Do not modify the product.
- Exercise reasonably and do not overextend. If you exercise for the first time, hold your handles firmly until you get used to the device.
- In case of error or damage stop the exercising immediately. If the treadmill suddenly increases its speed, remove the safety key.
- Connect the treadmill to socket after the treadmill is assembled. Use only grounded socket.
- If you are not using the device unplug it from socket and safety key removed.
- Any part of the treadmill cannot prohibit the movement of the user.
- Do not use outdoors.

- Do not expose to direct sunlight.
- Do not place in areas with high humidity (pools, sauna etc.)
- Continuous use cannot be longer than 2 hours.
- If the treadmill is not in use, remove the safety key.
- **Operation temperature:** 5 – 40 °C
- **Max. user weight:** 140 kg
- **Category:** HC (according to EN 957) suitable for home use.

SAFETY WARNING: Do not use heart rate sensors in the handle at speeds above 14 km / h.

WARNING! The heart rate monitoring system may not be accurate. Overextending during training can cause serious injury or death. If you feel nauseous, stop the exercise immediately!





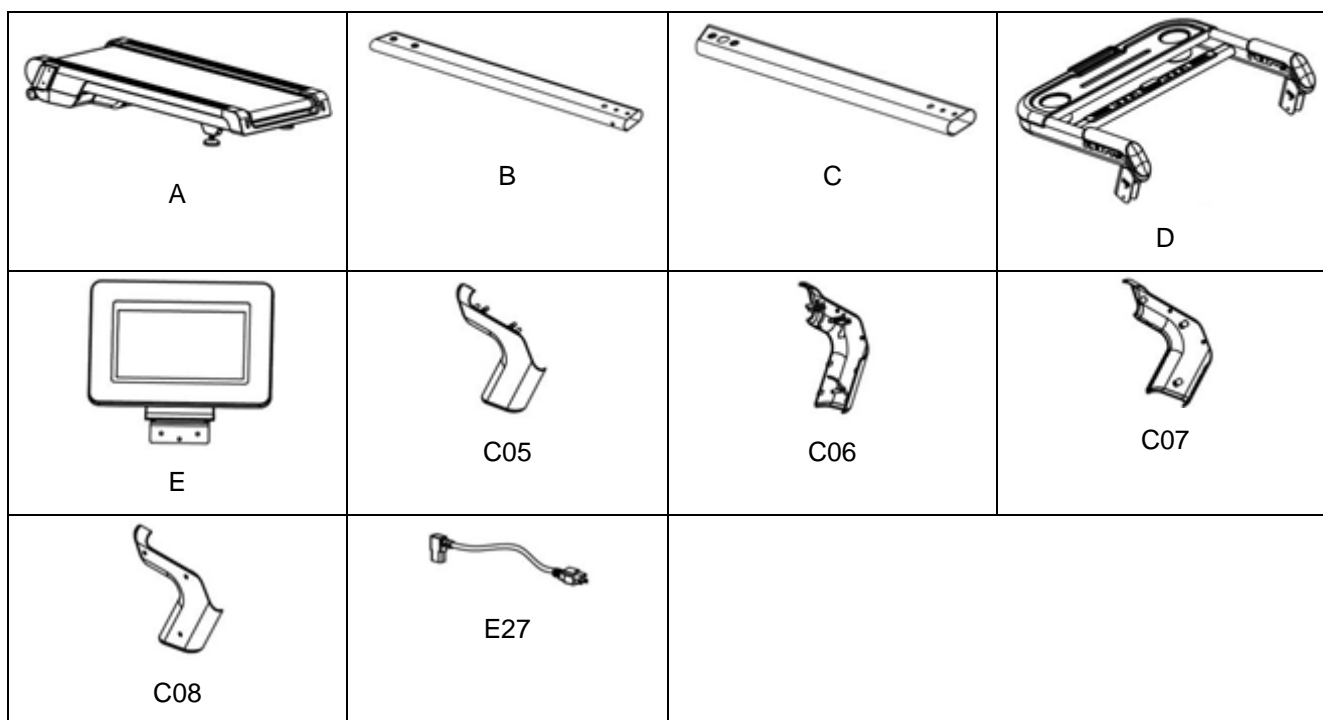

PACKAGE

Treadmill parts:

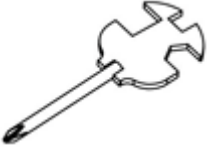
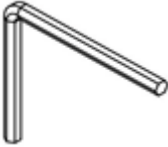
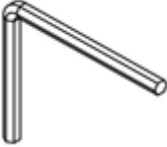

No.	Name	Qty	No.	Name	Qty
A	Treadmill	1	C05	Outside left post cover	1
B	Left post	1	C06	Outside right post cover	1
C	Right post	1	C07	Inner left post cover	1
D	Console holder	1	C8	Inner right post cover	1
E	Console	1	E27	Connection cable	1

Connection material:

B03: S=13,14,15 (1x)	B04: S5 (1x)	B05: S6 (1x)	D04: ST4.2x12 (10x)	D09: M8x15 (6x)
				
D13: M8x55 (3x)	D17: M10x50 (4x)	D22: Ø8 (7x)	D23: Ø8 (7x)	
				

ASSEMBLY

Step 1

Pull out treadmill with all parts and connection material. Check that all parts are present.

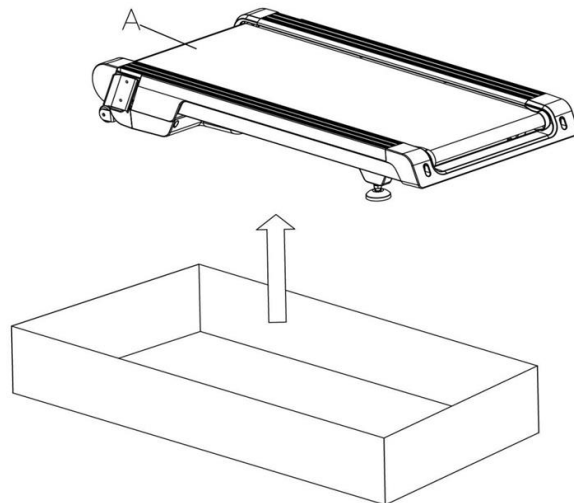

Step 2

Connect the cable (E09) from the main frame (A) to the cable (E08) from the post (C) and then connect the main frame (A) to the post (C) with 2x bolts (D17).



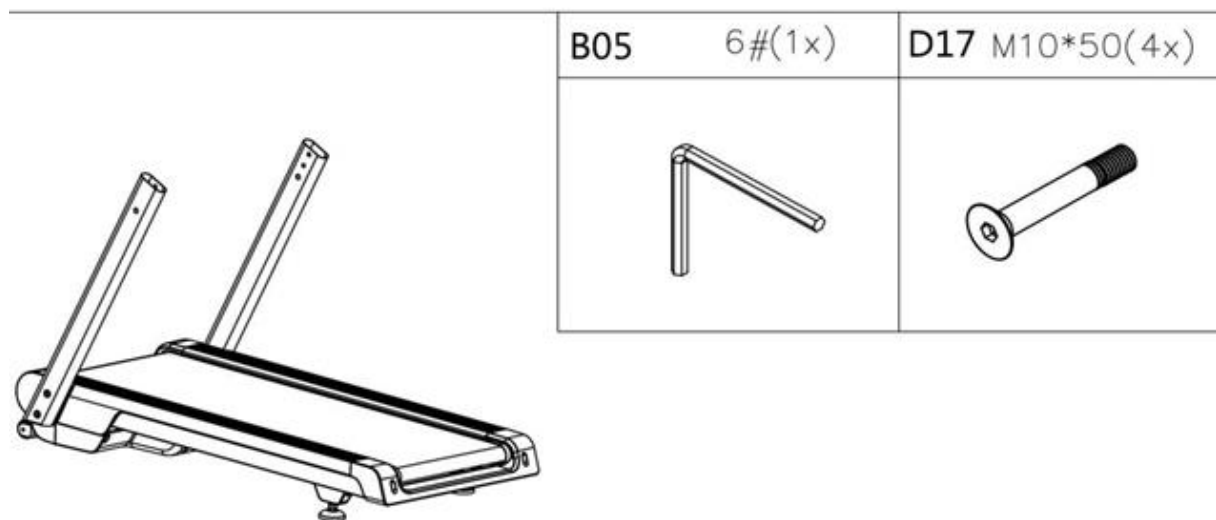
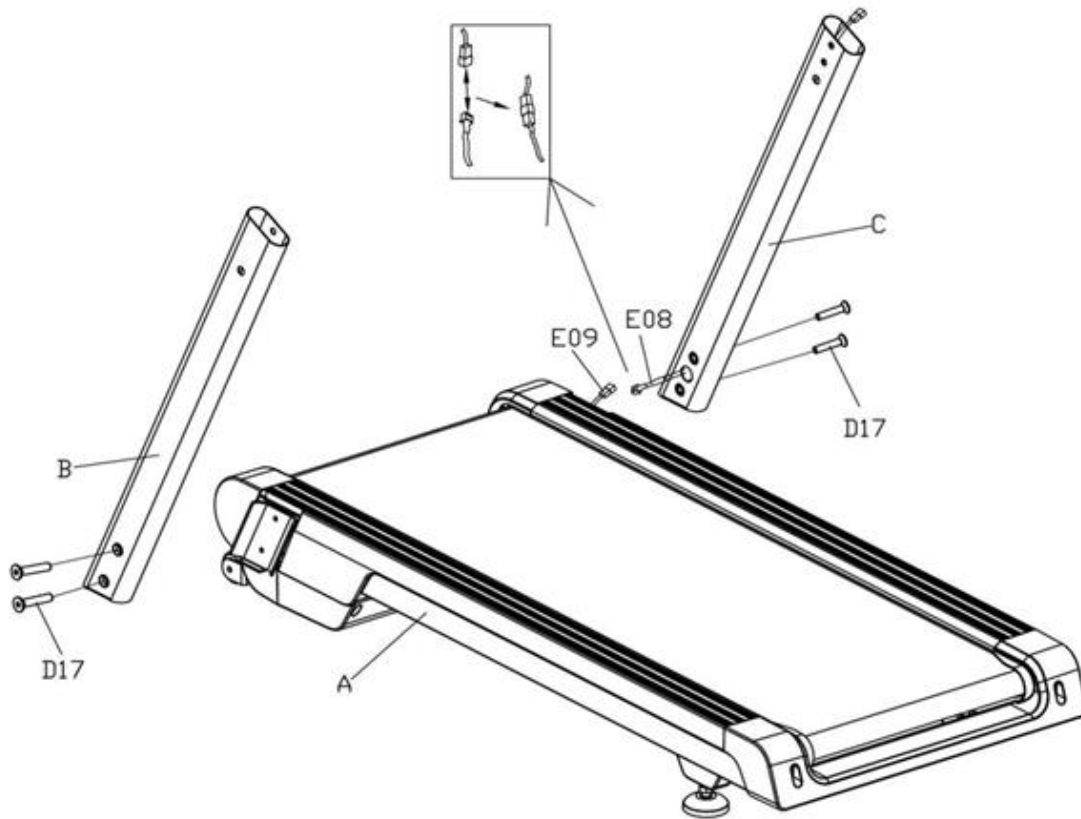

Attach the second post (B) to the main frame (A) with 2x bolts (D17).

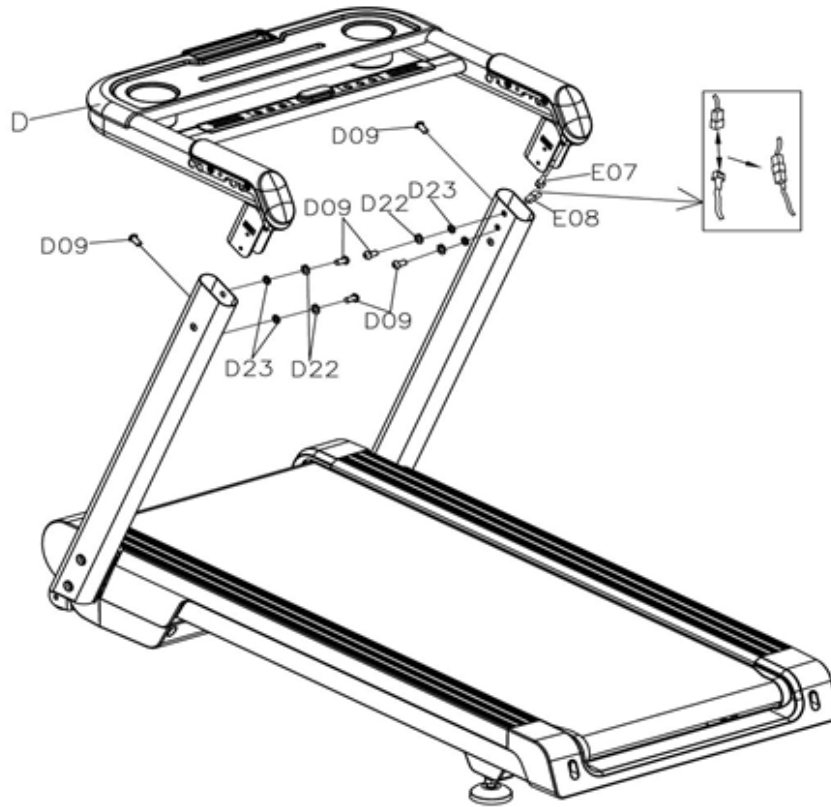

Step 3

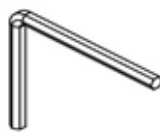
Attach the console bracket with handles (D) to the posts (B, C). Connect the cables (E07 and E08) leading from the console bracket (D) and the post (C). Attach the console holder (D) to the posts (B, C) with 3x bolts (D09), 2x washers (22) and 2x washers (23) on each side.





	B04 5#(1x)	D09 M8*15(6X)
		
	D22 $\phi 8(4X)$	D23 $\phi 8(4X)$
		

Step 4

Attach the covers (D05, C07) to the right post / handle using 5x screws (D04).

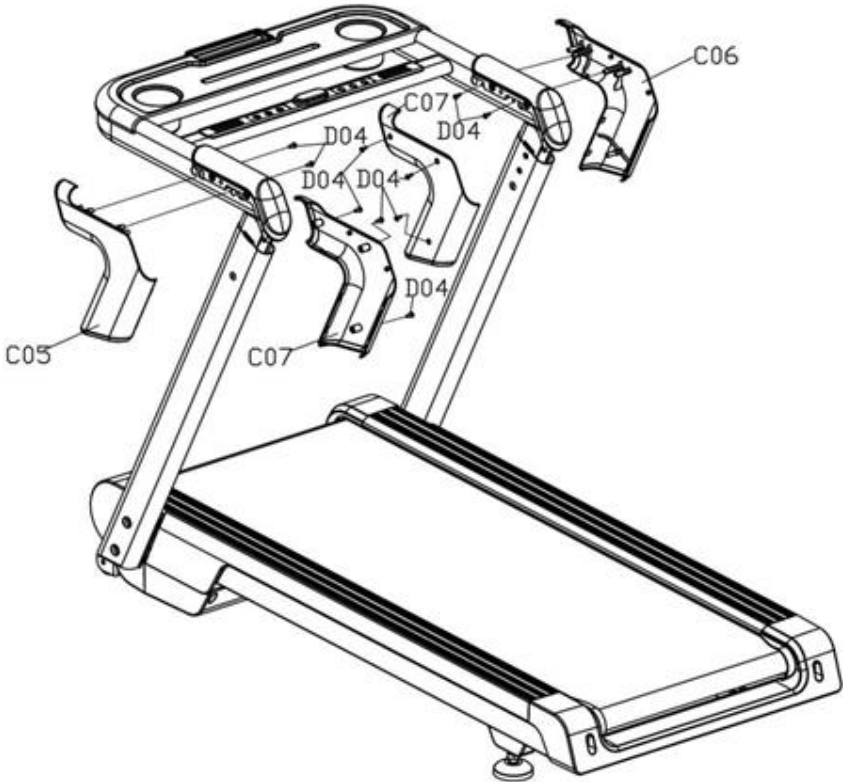
Attach the covers (C04, C06) to the left post / handle using 5x screws (D04).

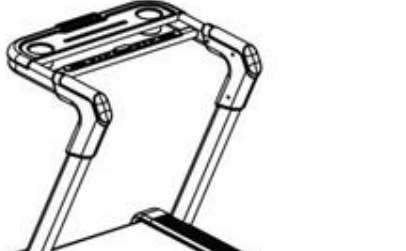



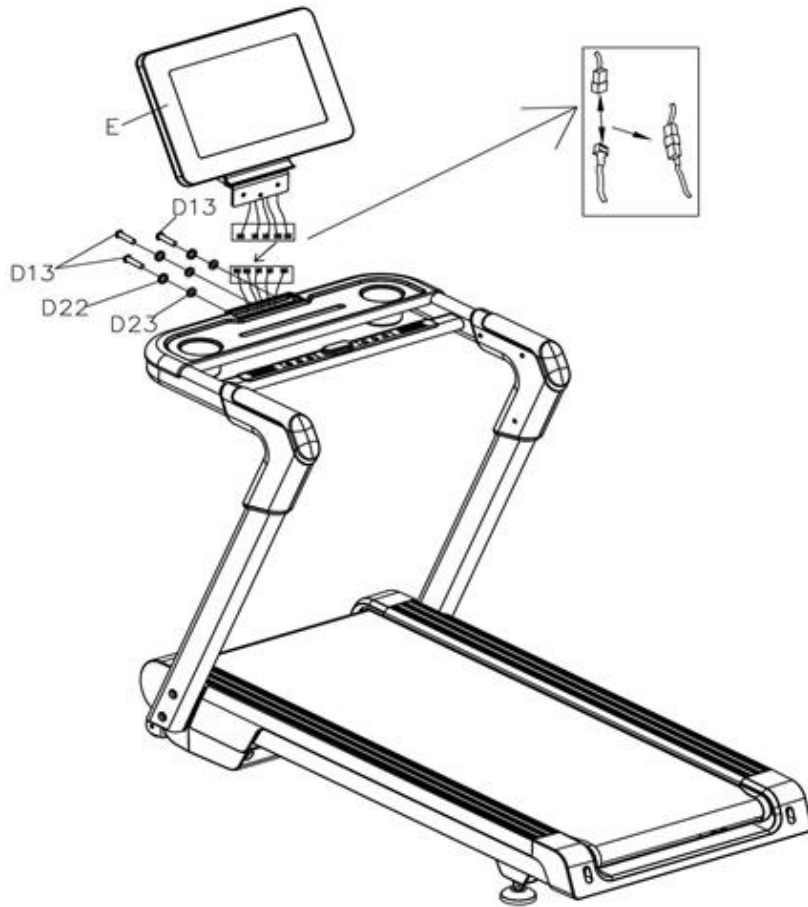

	B03 S=13、14、15(1X)	D04ST4.2*12 (10X)
		

Step 5

Attach the console (E) to the console bracket (D). Connect the cables and fasten the bracket with 3x bolts (D13), 3x washers (D22) and 3x washers (D23).



B04	5#(1x)	D13	M8*55(3X)
			
D22	∅8(3X)	D23	∅8(3X)
			

MOVING

Grasp the back of the treadmill and move the treadmill on the wheels.

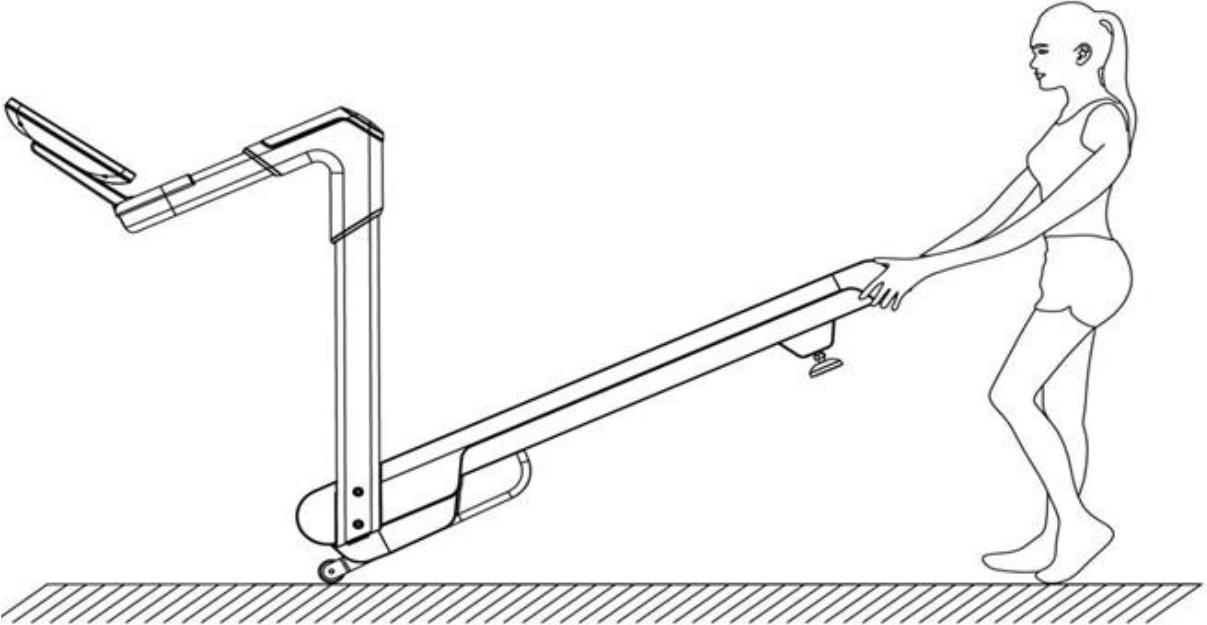
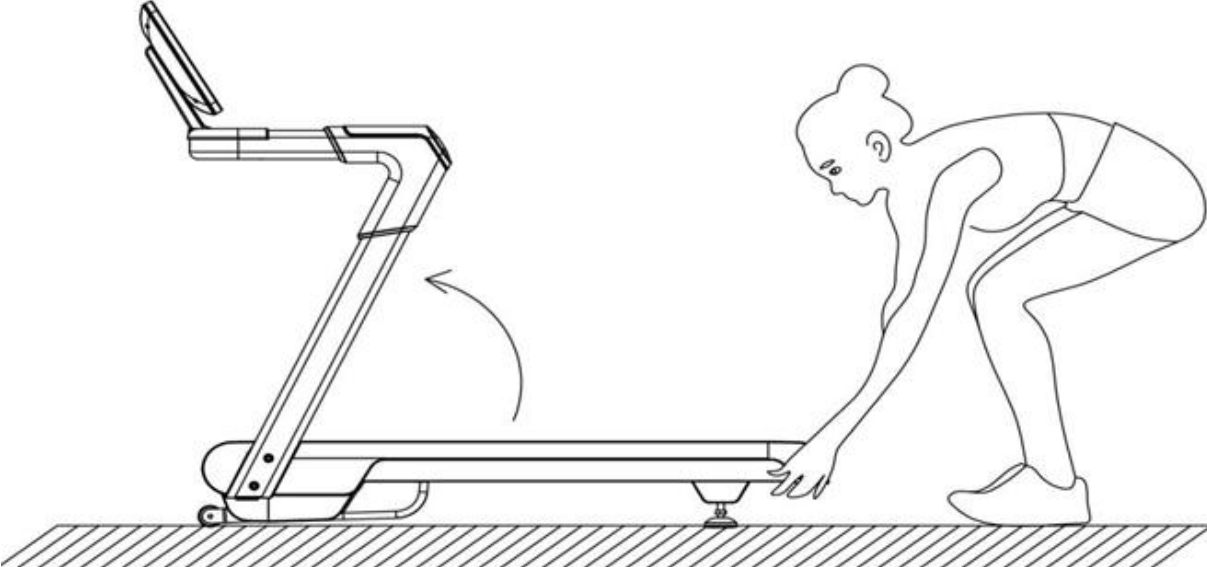

CONSOLE

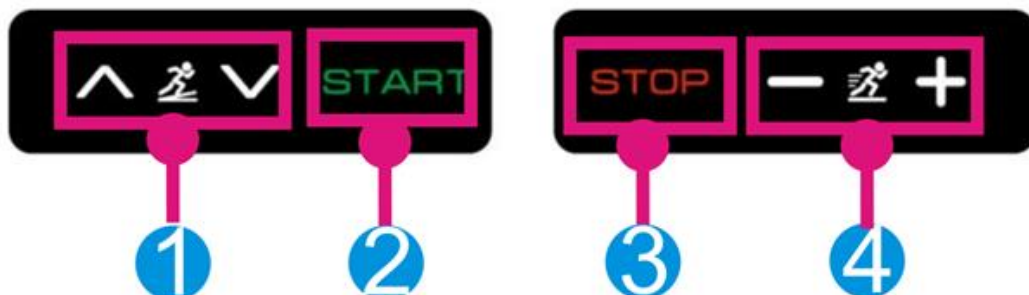
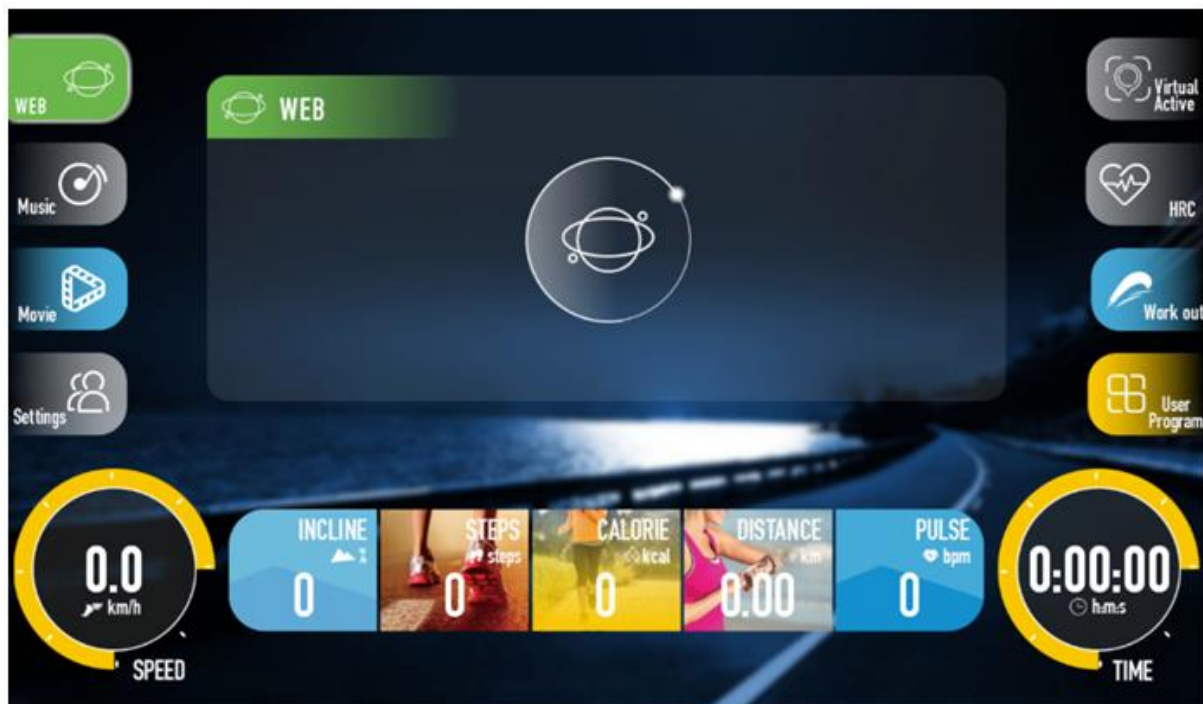

Funkce tlačítek:

1. **INCLINE +:** Press to increase incline.
2. **INCLINE -:** Press to decrease incline.
3. **START:** Press to turn on the treadmill.
4. **STOP/PAUSE:** Press to stop / pause the treadmill.
5. **SPEED +:** Press to increase speed.
6. **SPEED -:** Press to reduce speed.

Media (optional):

1. **MP3:** Use 3 mm cable to connect.
2. **USB:** You can use USB port to charge your device.

Console function:

1. **WEB:** The console contains several pre-installed apps. Make sure the console is connected to the internet so that you can use all the apps.
2. **MUSIC:** Display music in USB connected device.

3. **MOVIE:** Display videos in USB connected device.
4. **SETTING:** Setup of WI-Fi, language, backlight and user settings.
5. **VIRTUAL ACTIVE:** You can choose from several backgrounds.
6. **HRC:** Na výběr jsou 3 HRC programy. Pro správnou funkci musíte mít hrudní pás.
7. **WORK OUT:** Press to setup TIME , DISTANCE and CALORIES. Console includes 16 preset programs. Use buttons INCLINE +/- or SPEED +/- to adjust speed or incline.
8. **USER PROGRAM:** You can set your own user program U1 - U10. Use the display to set SPEED and INCLINE.

On any screen, you can press the dots to display the menu:

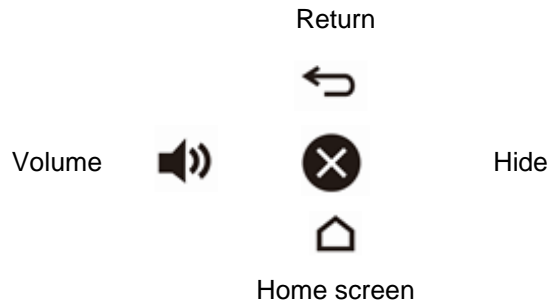

PULSE

Hold the sensors for 5 seconds. The display shows the user's pulse. The values are for guidance only and are not for medical or therapeutic purposes.

LUBRICATION NOTIFICATION

The treadmill automatically alerts the user. A warning is displayed after 300 km. The console will sound a beep every 10 seconds and the OIL will be displayed. Read the user manual before lubricating and then apply the lubricant to the center of the treadmill. After lubrication, press the STOP button for 3 seconds to turn off the alarm and notification.

SAFETY KEY

If the safety key is removed during exercising, the treadmill will stop. The display shows --- together with the beep. The treadmill will not work until the key is inserted again.

SAVING MODE

The belt is equipped with a power saving mode that starts after 10 minutes when the treadmill is not in use. Console shuts down, press any button to wake up console,

TURNIN ON / OFF THE TREADMILL

Press the button to turn on / off the treadmill (I) and (O) .

WARNING

- We recommend that you start exercising at a slower speed. Hold on to the handrails until you are confident to start exercising on higher speeds.
- Connect the safety key to the console and then to your clothes. In case of malfunction or problems, pull out the key.
- To stop safely, press the STOP button or remove the safety key.

MAINTENANCE GUIDE

General cleaning will help to prolong the life and improve performance on your treadmill. Keep the unit clean and maintained by dusting the components on a regular basis, cleaning the two exposed sides of the running belt to prevent dust from accumulating underneath the belt. Keep your running shoes clean so that dirt from the shoes does not wear the running belt. Clean the surface of the running belt using a clean damp cloth. Keep liquids away from electrical parts and running belt.

To prolong the lifespan of the treadmill it is recommended to turn it off every 2 hours of continuous use for at least 10 minutes.

A loose running belt will result in the runner sliding off when running, while too tight running belt will result in decrease of the motors performance and will also create more friction between the roller and running belt. The most suitable tightness for the belt is distance of 50-75mm from the running board.

ADJUSTING THE RUNNING BELT

Place the treadmill on level ground and set it at 3.5 – 5 km/h to check and see if the running belt (20) drifts from the center.

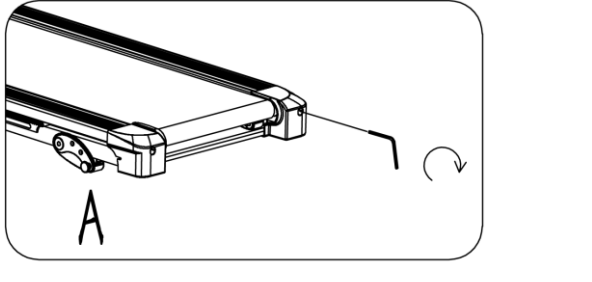
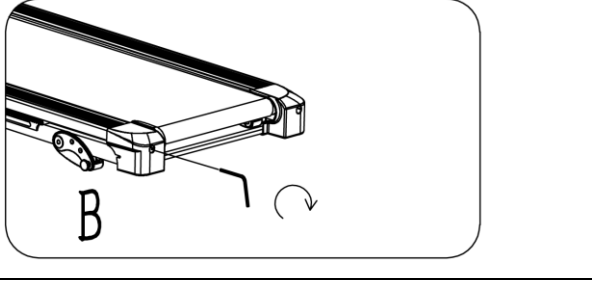
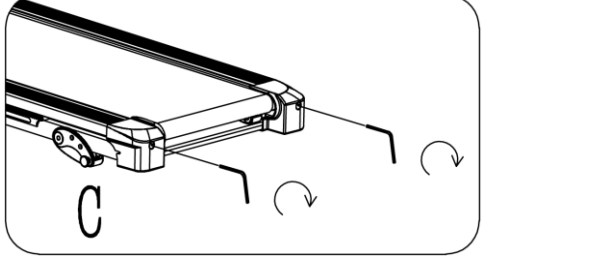
<p>If the running belt (20) drifts to the right, turn the adjusting bolt on the right side $\frac{1}{4}$ turn clockwise, then turn the left adjustment bolt $\frac{1}{4}$ turn counter-clockwise. If the belt does not move, repeat this step until it centers. Refer to image A.</p>	 Diagram A shows a side view of the treadmill's running belt assembly. The belt is shown drifting to the right. An arrow points to the right-side adjusting bolt with a clockwise rotation arrow. Another arrow points to the left-side adjusting bolt with a counter-clockwise rotation arrow. The letter 'A' is at the bottom left.
<p>If the running belt (20) drifts to the left, turn the adjusting bolt on the left side $\frac{1}{4}$ of a turn clockwise, then turn the right adjustment bolt $\frac{1}{4}$ turn counter-clockwise. If the belt does not move, repeat this step until it centers. Refer to image B.</p>	 Diagram B shows a side view of the treadmill's running belt assembly. The belt is shown drifting to the left. An arrow points to the left-side adjusting bolt with a clockwise rotation arrow. Another arrow points to the right-side adjusting bolt with a counter-clockwise rotation arrow. The letter 'B' is at the bottom left.
<p>Over time, the running belt (20) will loosen. To tighten the belt, turn both the left & right-side adjustment bolts one full turn clockwise. Check the tension of the belt. Continue this process until belt is at the correct tension. Make sure to adjust both sides equally to ensure even belt alignment. Refer to image C.</p>	 Diagram C shows a side view of the treadmill's running belt assembly. Two arrows point to both the left and right adjusting bolts, each with a clockwise rotation arrow. The letter 'C' is at the bottom left.

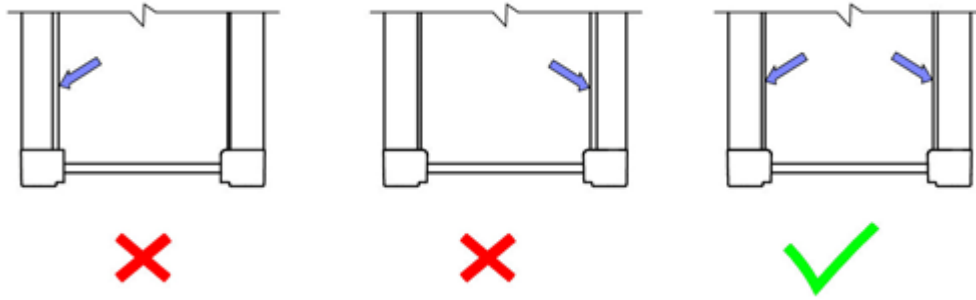

LUBRICATING THE TREADMILL

Lubricating the running belt & the running board is essential as the friction affects the life span and operations of the treadmill. Therefore, we suggest you to inspect the running belt regularly.

WARNING: Always unplug the treadmill from the electrical outlet before cleaning, lubricating, or repairing the unit.

The following time table is recommended:

Light user (less than 3 hours/week)	Every 6 months
Medium user (3 - 5 hours/week)	Every 3 months
Heavy user (more than 5 hours/week)	Every 2 months

How to lubricate the treadmill:

Lift up the belt on one side and apply a lubricant, then apply lubricate to entire surface with a cloth. repeat on the other side.

All moving parts must move freely and quietly. Abnormal movement may impair product safety. Check and tighten all screws regularly.

Proper and regular maintenance extends the lifespan of the treadmill.

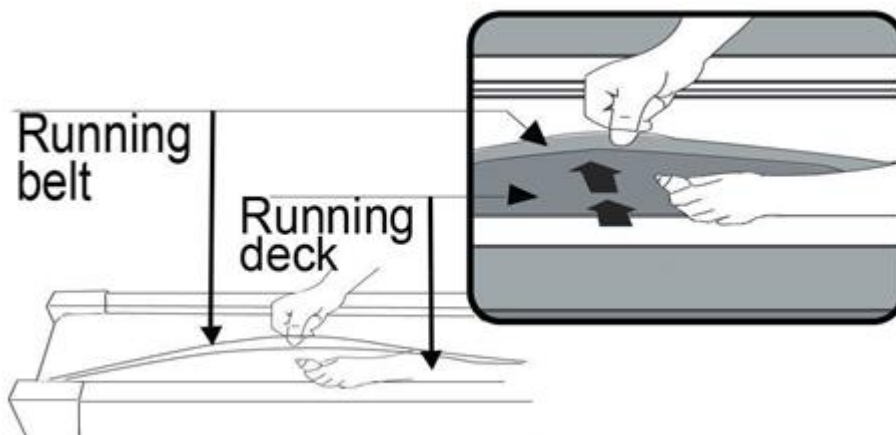

DIAGRAM

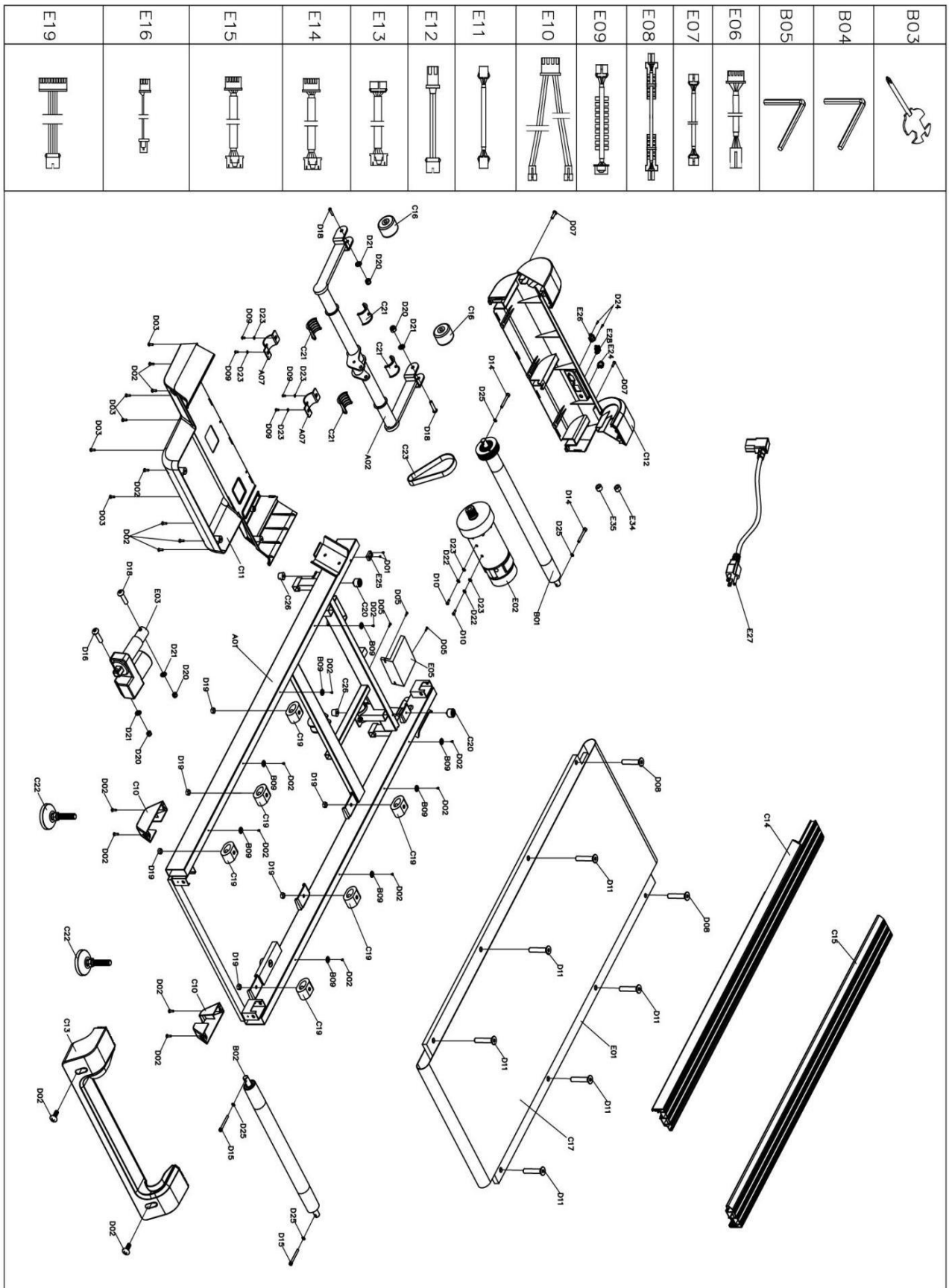

E20	
E21	
E29	
E30	
E31	
E32	
E33	
F01	
F02	
F03	
F04	
F05	

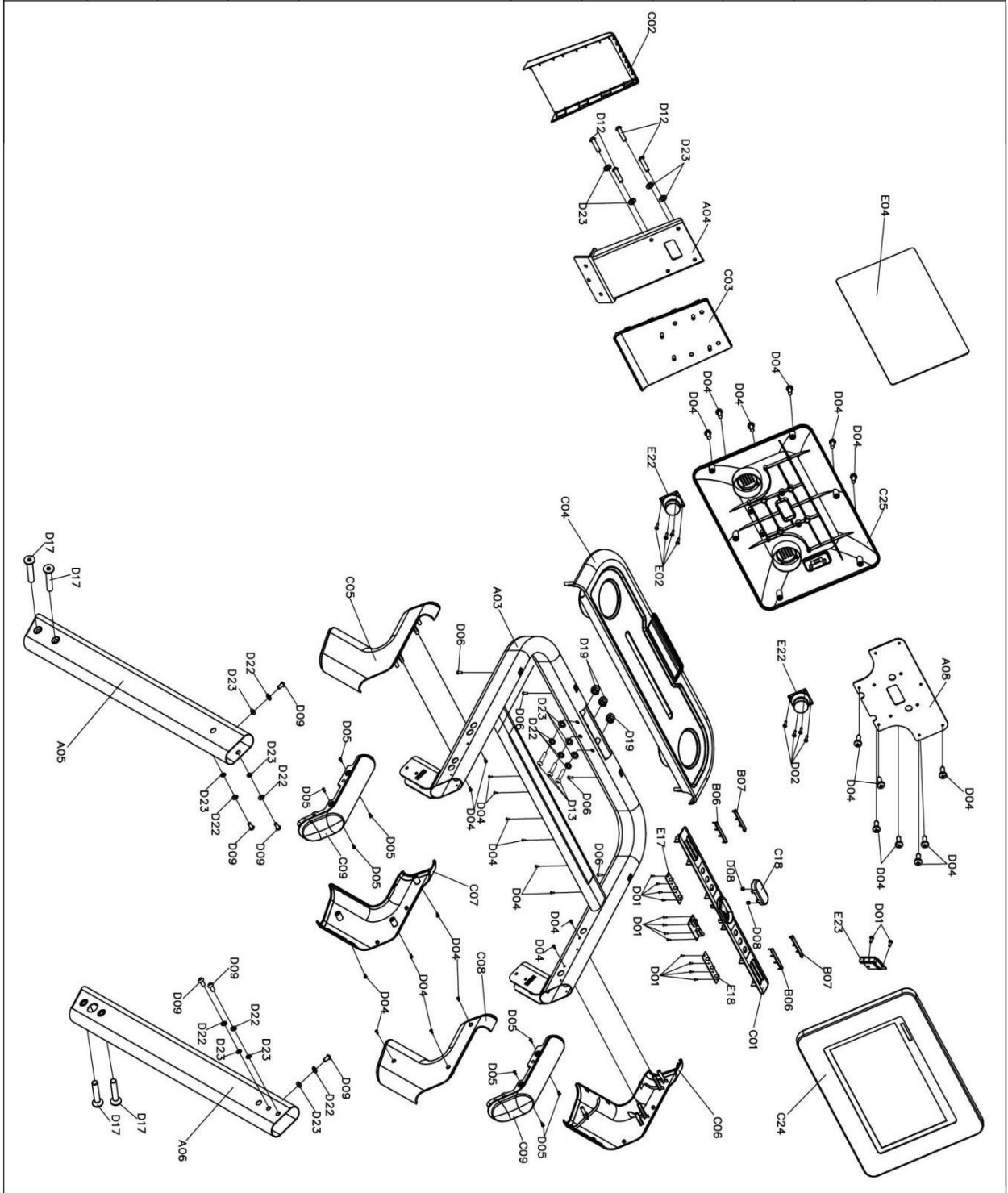

PARTS LIST

No	Name	Spec.	Qty	No	Name	Spec.	Qty
A01	Main frame		1	C19	Cushion		2
A02	Incline bracket		1	C20	Black cushion		2
A03	Console base bracket		1	C21	Nylon sleeve		4
A04	Console bracket		1	C22	Foot pad		2
A05	Left post		1	C23	Motor belt		1
A06	Right post		1	C24	Panel top cover		1
A07	Locking plate		2	C25	Panel bottom cover		1
A08	Screen fixing plate		1	C26	Cone-cushion		2
B01	Front roller		1	C27	Cushion		4
B02	Back roller		1	D01	Screw	ST2.9*8	22
B03	Wrench w/screwdriver	13,14,15	1	D02	Screw	ST4.2*12	21
B04	5# Allen wrench	5 mm	1	D03	Screw	ST4.2*12	5
B05	6# Allen wrench	6 mm	1	D04	Screw	ST4.2*12	29
B06	Left pulse steel plate		2	D05	Screw	ST4.2*12	12
B07	Right pulse steel plate		2	D06	Screw	ST4.2*20	4
B08	Spring 2		2	D07	Bolt	M5*12	2
B09	Side rail pad		8	D08	Bolt	M6*25	2
C01	Button top cover		1	D09	Bolt	M8*15	10
C02	Console holder bottom cover		1	D10	Bolt	M8*20	2
C03	Console holder top cover		1	D11	Bolt	M8*25	2
C04	Bottle base		1	D12	Bolt	M8*32 L15	4
C05	Outer left post cover		1	D13	Bolt	M8*60 L20	3
C06	Outer right post cover		1	D14	Bolt	M8*60	2
C07	Inner left post cover		1	D15	Bolt	M8*70	2
C08	Inner right post cover		1	D16	Bolt	M10*40 L15	1
C09	Handlebar		2	D17	Bolt	M10*50 L20	4
C10	Foot pad cover		2	D18	Bolt	M10*60 L20	1
C11	Motor bottom cover		1	D19	Nut	M8	9
C12	Motor front cover		1	D20	Nut	M10	4
C13	Back end cover		1	D21	Lock washer	10	4
C14	Left side rai		1	D22	Spring washer	8	13
C15	Right side rai		1	D23	Flat washer	8	17
C16	Wheel		2	D24	Screw	ST3.5*8	2
C17	Running belt		1	D25	Lock washer	8	4
C18	Emergency button		1	D26	Bolt	M10*65 L20	2

D27	Screw	ST2.9*8	4	E19	Panel connecting wire		1
E01	Running board		1	E20	Connecting wire		1
E02	DC motor		1	E21	Connecting wire 1		1
E03	Incline motor		1	E22	Speaker		2
E04	Console		1	E23	Bluetooth module		1
E05	Control board		1	E24	Overload protector		1
E06	Top signal wire		1	E25	Speed sensor		1
E07	Top signal wire 1		1	E26	Power socket		1
E08	Middle signal wire		1	E27	Power wire		1
E09	Bottom signal wire		1	E28	On-off switch		1
E10	Hand pulse top signal wire		1	E29	AC signal wire	Blue 350	1
E11	Hand pulse bottom signal wire		2	E30	AC signal wire	Brown 350	2
E12	Safety key sensor top signal wire		2	E31	AC signal wire	Brown 200	2
E13	Safety key sensor bottom signal wire		2	E32	AC signal wire	Blue 200	1
E14	Keyboard connecting wire		1	E33	Ground wire		1
E15	USB wire		1	E34	Magnetic ring		1
E16	USB wire		1	E35	Magnetic core		1
E17	Incline quick button board		1	E36	USB module		1
E18	Speed quick button board		1				

SPARE PARTS (NOT INCLUDED)

No	Name	Spec.	Qty	No	Name	Spec.	Qty
F01	Filter		1	F04	AC single wire		1
F02	Inductance		1	F05	Grounding wire		1
F03	AC single wire		1	F06	Screw	ST4.2*12	4

ENVIRONMENT PROTECTION

After the product lifespan expired or if the possible repairing is uneconomic, dispose it according to the local laws and environmentally friendly in the nearest scrapyard.

By proper disposal you will protect the environment and natural sources. Moreover, you can help protect human health. If you are not sure in correct disposing, ask local authorities to avoid law violation or sanctions.

Don't put the batteries among house waste but hand them in to the recycling place.

TERMS AND CONDITIONS OF WARRANTY, WARRANTY CLAIMS

General Conditions of Warranty and Definition of Terms

All Warranty Conditions stated here under determine Warranty Coverage and Warranty Claim Procedure. Conditions of Warranty and Warranty Claims are governed by Act No. 89/2012 Coll. Civil Code, and Act No. 634/1992 Coll., Consumer Protection, as amended, also in cases that are not specified by these Warranty rules.

The seller is SEVEN SPORT s.r.o. with its registered office in Strakonická street 1151/2c, Prague 150 00, Company Registration Number: 26847264, registered in the Trade Register at Regional Court in Prague, Section C, Insert No. 116888.

According to valid legal regulations it depends whether the Buyer is the End Customer or not.

“The Buyer who is the End Customer” or simply the “End Customer” is the legal entity that does not conclude and execute the Contract in order to run or promote his own trade or business activities.

“The Buyer who is not the End Customer” is a Businessman that buys Goods or uses services for the purpose of using the Goods or services for his own business activities. The Buyer conforms to the General Purchase Agreement and business conditions.

These Conditions of Warranty and Warranty Claims are an integral part of every Purchase Agreement made between the Seller and the Buyer. All Warranty Conditions are valid and binding, unless otherwise specified in the Purchase Agreement, in the Amendment to this Contract or in another written agreement.

Warranty Conditions

Warranty Period

The Seller provides the Buyer a 24 months Warranty for Goods Quality, unless otherwise specified in the Certificate of Warranty, Invoice, Bill of Delivery or other documents related to the Goods. The legal warranty period provided to the Consumer is not affected.

By the Warranty for Goods Quality, the Seller guarantees that the delivered Goods shall be, for a certain period of time, suitable for regular or contracted use, and that the Goods shall maintain its regular or contracted features.

The Warranty does not cover defects resulting from (if applicable):

- User's fault, i.e. product damage caused by unqualified repair work, improper assembly, insufficient insertion of seat post into frame, insufficient tightening of pedals and cranks
- Improper maintenance
- Mechanical damages
- Regular use (e.g. wearing out of rubber and plastic parts, moving mechanisms, joints, wear of brake pads/blocks, chain, tires, cassette/multi wheel etc.)
- Unavoidable event, natural disaster
- Adjustments made by unqualified person
- Improper maintenance, improper placement, damages caused by low or high temperature, water, inappropriate pressure, shocks, intentional changes in design or construction etc.

Warranty Claim Procedure

The Buyer is obliged to check the Goods delivered by the Seller immediately after taking the responsibility for the Goods and its damages, i.e. immediately after its delivery. The Buyer must check the Goods so that he discovers all the defects that can be discovered by such check.

When making a Warranty Claim the Buyer is obliged, on request of the Seller, to prove the purchase and validity of the claim by the Invoice or Bill of Delivery that includes the product's serial number, or eventually by the documents without the serial number. If the Buyer does not prove the validity of the Warranty Claim by these documents, the Seller has the right to reject the Warranty Claim.

If the Buyer gives notice of a defect that is not covered by the Warranty (e.g. in the case that the Warranty Conditions were not fulfilled or in the case of reporting the defect by mistake etc.), the Seller is eligible to require a compensation for all the costs arising from the repair. The cost shall be calculated according to the valid price list of services and transport costs.

If the Seller finds out (by testing) that the product is not damaged, the Warranty Claim is not accepted. The Seller reserves the right to claim a compensation for costs arising from the false Warranty Claim.

In case the Buyer makes a claim about the Goods that is legally covered by the Warranty provided by the Seller, the Seller shall fix the reported defects by means of repair or by the exchange of the damaged part or product for a new one. Based on the agreement of the Buyer, the Seller has the right to exchange the defected Goods for a fully compatible Goods of the same or better technical characteristics. The Seller is entitled to choose the form of the Warranty Claim Procedures described in this paragraph.

The Seller shall settle the Warranty Claim within 30 days after the delivery of the defective Goods, unless a longer period has been agreed upon. The day when the repaired or exchanged Goods is handed over to the Buyer is considered to be the day of the Warranty Claim settlement. When the Seller is not able to settle the Warranty Claim within the agreed period due to the specific nature of the Goods defect, he and the Buyer shall make an agreement about an alternative solution. In case such agreement is not made, the Seller is obliged to provide the Buyer with a financial compensation in the form of a refund.

CZ
SEVEN SPORT s.r.o.

Registered Office: Strakonická 1151/2c, Praha 5, 150 00, ČR
Headquarters: Dělnická 957, Vítkov, 749 01
Warranty & Service: Čermenská 486, Vítkov 749 01

CRN: 26847264
VAT ID: CZ26847264

Phone: +420 556 300 970
E-mail: eshop@insportline.cz
reklamace@insportline.cz
servis@insportline.cz

Web: www.inSPORTline.cz

SK
inSPORTline s.r.o.

Headquarters, warranty & service center: Električná 6471, Trenčín 911 01, SK

CRN: 36311723
VAT ID: SK2020177082

Phone: +421(0)326 526 701
E-mail: objednavky@insportline.sk
reklamacie@insportline.sk
servis@insportline.sk

Web: www.inSPORTline.sk