



**USER MANUAL – EN**

**IN 2043, 2045 Trampoline Tent – 224 cm, 366 cm**



# CONTENTS





SAFETY INSTRUCTIONS..... 3  
PARTS LIST ..... 3  
ASSEMBLY ..... 4  
FOLDING..... 6  
STORAGE ..... 7  
ENVIRONMENT PROTECTION ..... 7  
TERMS AND CONDITIONS OF WARRANTY, WARRANTY CLAIMS..... 7

## SAFETY INSTRUCTIONS

- Read the manual carefully and keep it for future references.
- Read the manual carefully before assembly.
- Assembly can me only done by adult person.
- The tent can be used only under adult supervision.
- Keep away any heat sources and keep away from open fire and flames.
- Protect the tent from sharp objects and pets.
- During extreme weather conditions (windy weather etc.) it is recommended to fold the tent.
- Follow all instructions about assembly and safety.
- Prolonged exposure to the sun and elements (especially UV rays) will shorten the lifespan of the tent. Use trampoline cover. Remove the tent when not in use for linger periods of time or during extreme weather conditions.
- For child protection:
  - Adult supervision is required
  - To prevent falls and strangulation exit the tent via doors only
  - Help children in and out of the tent
  - During high temperatures keep all doors and windows open to reduce the heat build-up.
  - Frame pads must be placed before the tent assembly.

**WARNING:** There is a risk of carbon monoxide poisoning, when the tent is not ventilated properly.

## PARTS LIST

No.	Name	Picture	Qty.
1	Pole		3
2	Connector		2
3	Bracket		2
4	Bolt		2

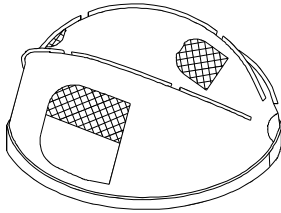
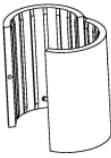
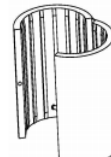
5	Tent		1
6	Tube $\Phi 42$		2
7	Tube $\Phi 38$		2

## ASSEMBLY

### STEP 1

Assemble the three fiberglass poles by joining the three sections with connectors on the poles. Inside a pole is an elastic cord to keep them together. The poles should have the same length.

Be careful not to squeak your fingers into the moving parts.

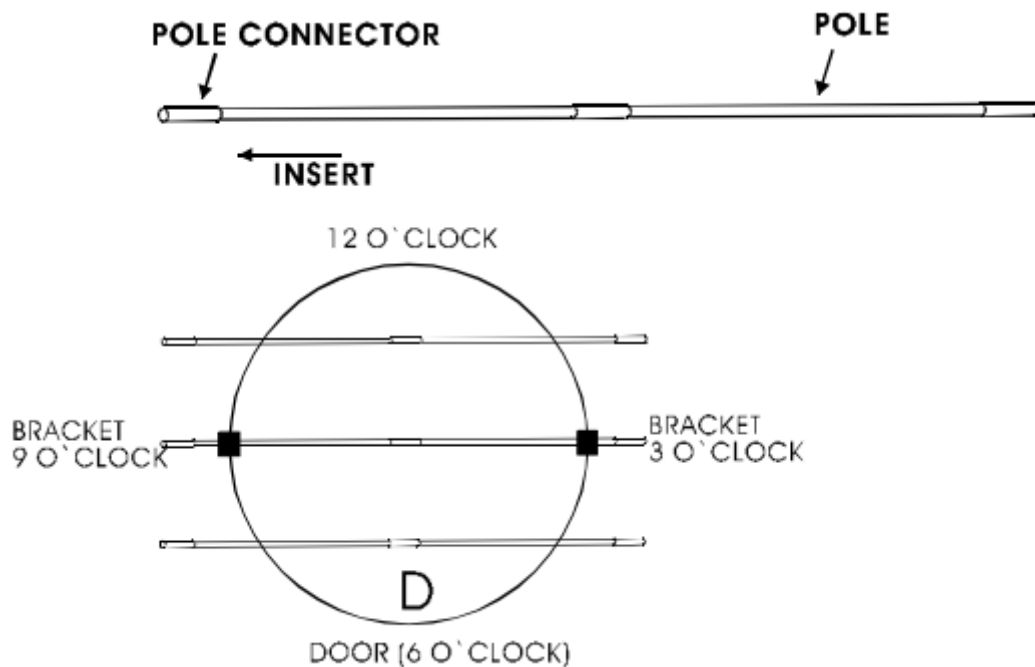

## STEP 2

Now place the tent on the trampoline and decide where will the entrance face. Entrance is marked by "D" and has a zipper on the outside and inside. This will be the main entrance. Make sure that there are 3 sleeves that divide the tent into 4 parts and sleeves are up against the top frame (the curved parts of tent are against the mat)

Now slide the poles through the sleeves. Do not use force, if the poles get caught up in the fabric release it. Slide all poles.

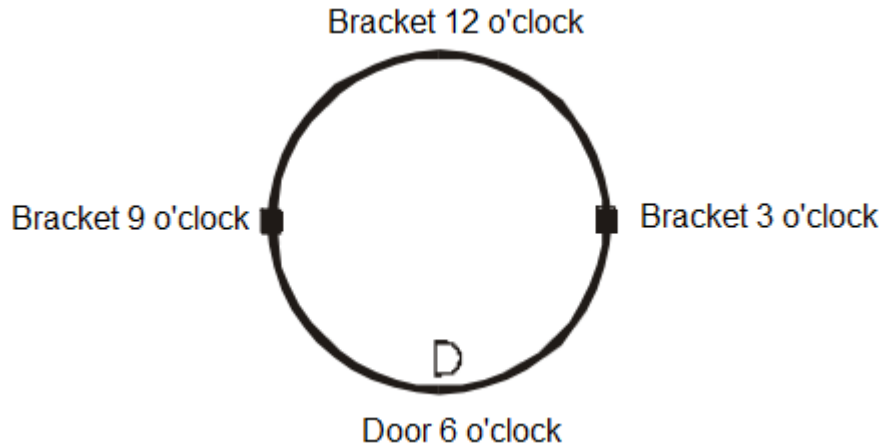

## STEP 3

Please check the diameter of trampoline legs  $\Phi 48$ ,  $\Phi 42$ ,  $\Phi 38$  and refer to correct step.

### $\Phi 48$

Locate two opposite legs of the trampoline. Place the brackets onto the trampoline frame, place the curved part onto the frame. Make sure it is placed from inside out and is placed against the trampoline leg. Then attach the pole holders to the bracket and connect them with the screw.

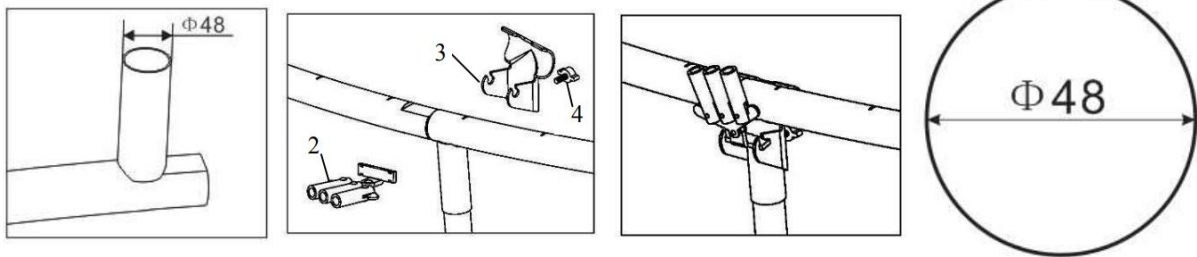

### $\Phi 42$

Locate two opposite legs of the trampoline. Place the tubes to thicken the trampoline legs. Place the brackets onto the trampoline frame, place the curved part onto the frame. Make sure it is placed from inside out and is placed against the trampoline leg. Then attach the pole holders to the bracket and connect them with the screw.

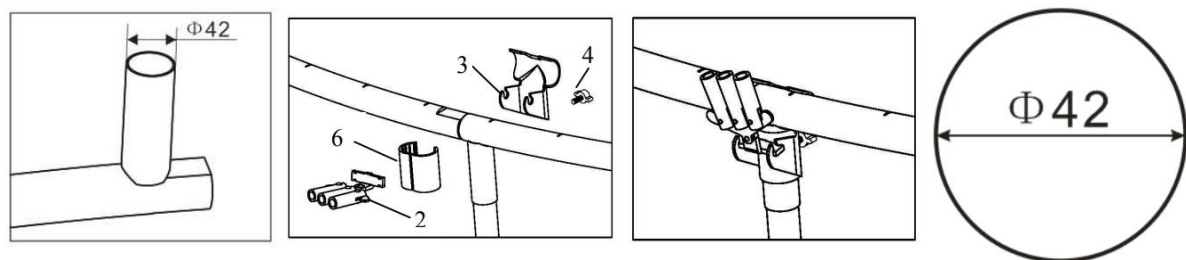

## Φ38

Locate two opposite legs of the trampoline. Place the tubes to thicken the trampoline legs. Place the brackets onto the trampoline frame, place the curved part onto the frame. Make sure it is placed from inside out and is placed against the trampoline leg. Then attach the pole holders to the bracket and connect them with the screw.

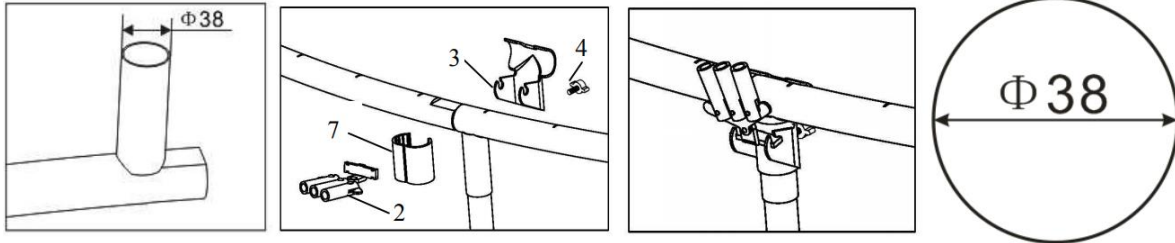

## STEP 4

Now connect the poles to the brackets. After you inserted all poles, the tent should cover the whole trampoline. Pull the tent to the end of the trampoline and secure it with sew in straps. Then cover the brackets with bends on the tent.

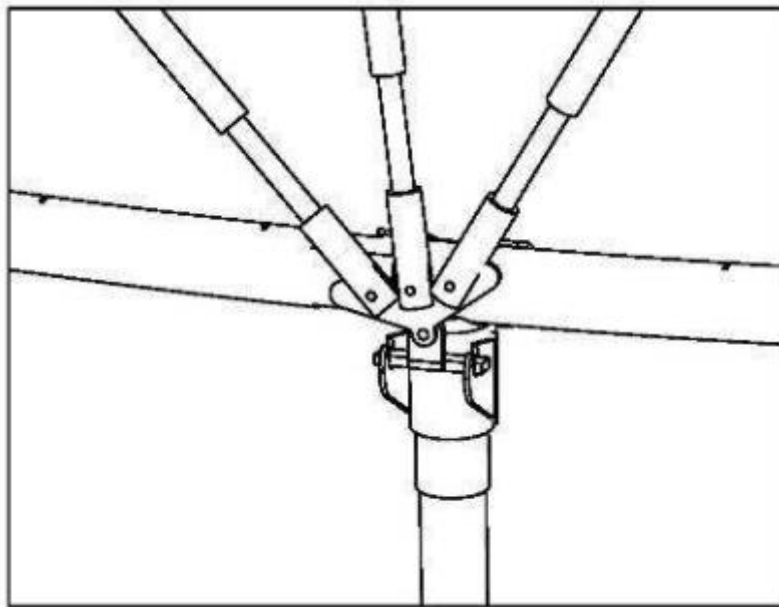

## FOLDING

To fold the tent, you need to remove the straps and bands and then push the poles in the brackets down.



## STORAGE

Make sure that the tent is dry. Follow the assembly steps in reverse. The tent brackets do not need to be removed. Store the tent in dry and shade place.

## ENVIRONMENT PROTECTION

After the product lifespan expired or if the possible repairing is uneconomic, dispose it according to the local laws and environmentally friendly in the nearest scrapyard.

By proper disposal you will protect the environment and natural sources. Moreover, you can help protect human health. If you are not sure in correct disposing, ask local authorities to avoid law violation or sanctions.

Don't put the batteries among house waste but hand them in to the recycling place.

## TERMS AND CONDITIONS OF WARRANTY, WARRANTY CLAIMS

### General Conditions of Warranty and Definition of Terms

All Warranty Conditions stated here under determine Warranty Coverage and Warranty Claim Procedure. Conditions of Warranty and Warranty Claims are governed by Act No. 89/2012 Coll. Civil Code, and Act No. 634/1992 Coll., Consumer Protection, as amended, also in cases that are not specified by these Warranty rules.

The seller is SEVEN SPORT s.r.o. with its registered office in Strakonická street 1151/2c, Prague 150 00, Company Registration Number: 26847264, registered in the Trade Register at Regional Court in Prague, Section C, Insert No. 116888.

According to valid legal regulations it depends whether the Buyer is the End Customer or not.

"The Buyer who is the End Customer" or simply the "End Customer" is the legal entity that does not conclude and execute the Contract in order to run or promote his own trade or business activities.

"The Buyer who is not the End Customer" is a Businessman that buys Goods or uses services for the purpose of using the Goods or services for his own business activities. The Buyer conforms to the General Purchase Agreement and business conditions.

These Conditions of Warranty and Warranty Claims are an integral part of every Purchase Agreement made between the Seller and the Buyer. All Warranty Conditions are valid and binding, unless otherwise specified in the Purchase Agreement, in the Amendment to this Contract or in another written agreement.

### Warranty Conditions

#### Warranty Period

The Seller provides the Buyer a 24 months Warranty for Goods Quality, unless otherwise specified in the Certificate of Warranty, Invoice, Bill of Delivery or other documents related to the Goods. The legal warranty period provided to the Consumer is not affected.

By the Warranty for Goods Quality, the Seller guarantees that the delivered Goods shall be, for a certain period of time, suitable for regular or contracted use, and that the Goods shall maintain its regular or contracted features.

#### The Warranty does not cover defects resulting from (if applicable):

- User's fault, i.e. product damage caused by unqualified repair work, improper assembly, insufficient insertion of seat post into frame, insufficient tightening of pedals and cranks
- Improper maintenance
- Mechanical damages
- Regular use (e.g. wearing out of rubber and plastic parts, moving mechanisms, joints, wear of brake pads/blocks, chain, tires, cassette/multi wheel etc.)

- Unavoidable event, natural disaster
- Adjustments made by unqualified person
- Improper maintenance, improper placement, damages caused by low or high temperature, water, inappropriate pressure, shocks, intentional changes in design or construction etc.

### **Warranty Claim Procedure**

The Buyer is obliged to check the Goods delivered by the Seller immediately after taking the responsibility for the Goods and its damages, i.e. immediately after its delivery. The Buyer must check the Goods so that he discovers all the defects that can be discovered by such check.

When making a Warranty Claim the Buyer is obliged, on request of the Seller, to prove the purchase and validity of the claim by the Invoice or Bill of Delivery that includes the product's serial number, or eventually by the documents without the serial number. If the Buyer does not prove the validity of the Warranty Claim by these documents, the Seller has the right to reject the Warranty Claim.

If the Buyer gives notice of a defect that is not covered by the Warranty (e.g. in the case that the Warranty Conditions were not fulfilled or in the case of reporting the defect by mistake etc.), the Seller is eligible to require a compensation for all the costs arising from the repair. The cost shall be calculated according to the valid price list of services and transport costs.

If the Seller finds out (by testing) that the product is not damaged, the Warranty Claim is not accepted. The Seller reserves the right to claim a compensation for costs arising from the false Warranty Claim.

In case the Buyer makes a claim about the Goods that is legally covered by the Warranty provided by the Seller, the Seller shall fix the reported defects by means of repair or by the exchange of the damaged part or product for a new one. Based on the agreement of the Buyer, the Seller has the right to exchange the defected Goods for a fully compatible Goods of the same or better technical characteristics. The Seller is entitled to choose the form of the Warranty Claim Procedures described in this paragraph.

The Seller shall settle the Warranty Claim within 30 days after the delivery of the defective Goods, unless a longer period has been agreed upon. The day when the repaired or exchanged Goods is handed over to the Buyer is considered to be the day of the Warranty Claim settlement. When the Seller is not able to settle the Warranty Claim within the agreed period due to the specific nature of the Goods defect, he and the Buyer shall make an agreement about an alternative solution. In case such agreement is not made, the Seller is obliged to provide the Buyer with a financial compensation in the form of a refund.

#### **CZ**

##### **SEVEN SPORT s.r.o.**

Registered Office: Strakonická 1151/2c, Praha 5, 150 00, ČR  
 Headquarters: Dělnická 957, Vítkov, 749 01  
 Warranty & Service: Čermenská 486, Vítkov 749 01

CRN: 26847264  
 VAT ID: CZ26847264

Phone: +420 556 300 970  
 E-mail: eshop@insportline.cz  
 reklamace@insportline.cz  
 servis@insportline.cz

Web: www.inSPORTline.cz

#### **SK**

##### **inSPORTline s.r.o.**

Headquarters, warranty & service center: Električná 6471, Trenčín 911 01, SK

CRN: 36311723  
 VAT ID: SK2020177082

Phone: +421(0)326 526 701  
 E-mail: objednavky@insportline.sk  
 reklamacie@insportline.sk  
 servis@insportline.sk

Web: www.inSPORTline.sk