

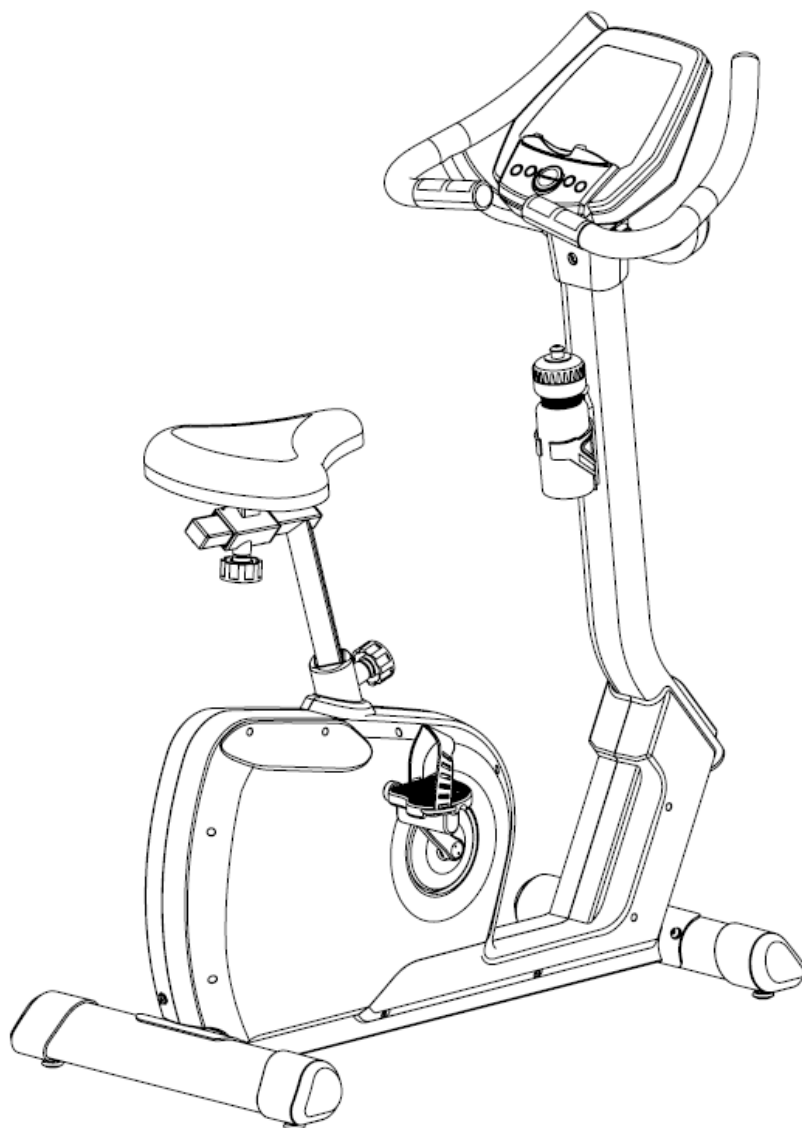

USER MANUAL – EN

IN 20145 Exercise bike inSPORTline Valdosa



CONTENTS

SAFETY INSTRUCTIONS 3

IMPORTANT NOTES 3

PARTS LIST 4

ASSEMBLY 6

CONSOLE11

USE19

CORRECT BODY POSTURE19

MAINTENANCE20

STORAGE20

IMPORTANT NOTICE20

ENVIRONMENT PROTECTION.....20

TERMS AND CONDITIONS OF WARRANTY, WARRANTY CLAIMS.....20

SAFETY INSTRUCTIONS

- To ensure the best safety of the exerciser, regularly check it on damages and worn parts.
- If you pass on this exerciser to another person or if you allow another person to use it, make sure that that person is familiar with the content and instructions in these instructions.
- Only one person should use the exerciser at a time.
- Before the first use and regularly make sure that all screws, bolts and other joints are properly tightened and firmly seated.
- Before you start your work-out, remove all sharp-edged objects around the exerciser.
- Only use the exercise for your work-out if it works flawlessly.
- Any broken, worn or defective part must immediately be replaced and/or the exerciser must no longer be used until it has been properly maintained and repaired.
- Parents and other supervisory persons should be aware of their responsibility, due to situations which may arise for which the exerciser has not been designed and which may occur due to children's natural play instinct and interest in experimenting.
- If you do allow children to use this exerciser, be sure to take into consideration and assess their mental and physical condition and development, and above all their temperament. Children should use the exerciser only under adult supervision and be instructed on the correct and proper use of the exerciser. The exerciser is not a toy.
- Make sure there is sufficient free space around the exerciser when you set it up min 0.6 m.
- To avoid possible accidents, do not allow children to approach the exerciser without supervision, since they may use it in a way for which it is not intended due to their natural play instinct and interest in experimenting.
- Please note that an improper and excessive work-out may be harmful to your health.
- Please note that levers and other adjustment mechanisms are not projecting into the area of movement during the work-out.
- When setting up the exerciser, please make sure that the exerciser is standing in a stable way and that any possible unevenness of the floor is evened out.
- Always wear appropriate clothing and shoes which are suitable for your work-out on the exerciser. The clothes must be designed in a way so that they will not get caught in any part of the exerciser during the work-out due to their form (for example, length). Be sure to wear appropriate shoes which are suitable for the work-out, firmly support the feet and which are provided with a non-slip sole.
- Be sure to consult a physician before you start any exercise program. He may give you proper hints and advice with respect to the individual intensity of stress for you as well as to your work-out and sensible eating habits.
- Maximal weight: 130 kg
- Category: HC for home use
- Meets standards: EN ISO 2095-1 : 2013, EN 957-5 : 2009





IMPORTANT NOTES





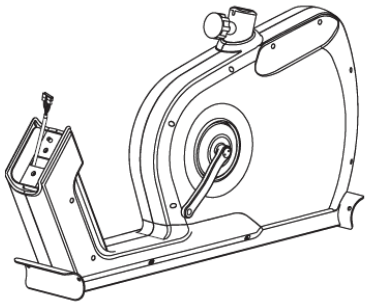
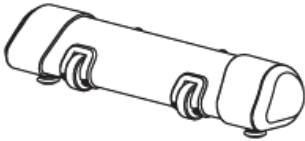

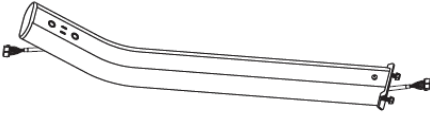

- Assemble the exerciser as per assembly instructions and be sure to only use the structural parts provided with the exerciser and designed for it. Prior to the assembly, make sure the contents of the delivery is complete by referring to the parts list of the assembly and operating instructions.

- Be sure to set up the exerciser in a dry and even place and always protect it from humidity. If you wish to protect the place particularly against pressure points, contamination, etc., it is recommended to put a suitable, non-slip mat under the exerciser.
- The general rule is that exercisers and training devices are no toys. Therefore, they must only be used by properly informed or instructed persons.
- Stop your work-out immediately in case of dizziness, nausea, chest pain or any other physical symptoms. In case of doubt, consult your physician immediately.
- Children, disabled and handicapped persons should use the exercise only under supervision and in presence of another person who may give support and useful instructions.
- Be sure that your body parts and those of other persons are never close to any moving parts of the exerciser during its use.
- When adjusting the adjustable parts, make sure they are adjusted properly and note the marked, maximum adjusting position, for example of the saddle support, respectively.
- Do not work out immediately after meals!

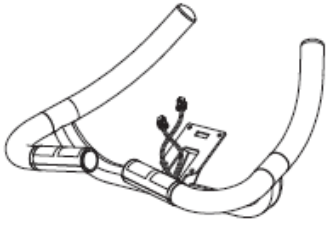
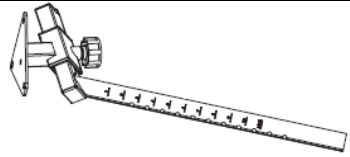
WARNING! A system for monitoring heart rate may not be accurate. Overloading during training may cause serious injury or death. If you feel any discomfort, immediately stop the exercise!

PARTS LIST

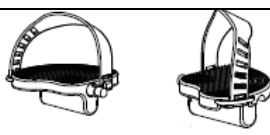
	A	Main frame
	B	Front stabilizer
	C	Rear stabilizer
	D	Middle post
	D2	Plastic cover

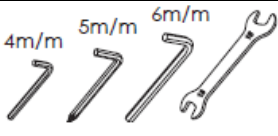
	D3	Front plastic cover
	D4	Rear plastic cover
	E	Handlebars
	F	Seat tube and seat basement
	G	Console
	H	Seat
	J4	Screw M10 x 70 mm
	J5	Washer M10
	K1/K2	Left and right pedals
	L1/L2	Bottle holder and bottle
		Tools

ASSEMBLY

STEP 1

Remove the pre-installed screws (J1), spring washers (J2) and washers (J3) from the rear stabilizer (C).

Attach the rear stabilizer (C) to the main frame (A) with screws (J1), spring washer (J2) and washer (J3).

You need a 5 mm Allen key.

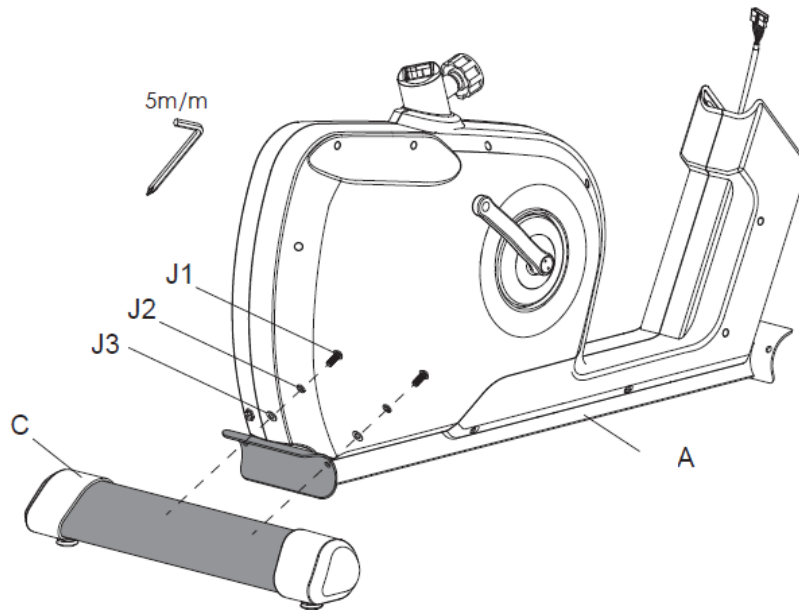

STEP 2

Remove the pre-installed bolts (J1), spring washers (J2) and washers (J3) from the front stabilizer (C).
Secure the front stabilizer (C) to the main frame (A) with screws (J1), spring washer (J2) and washer (J3).

You need a 5 mm Allen key.

NOTE: Make sure that the exercise bike is stable if not adjust the stabilizing feet if necessary.

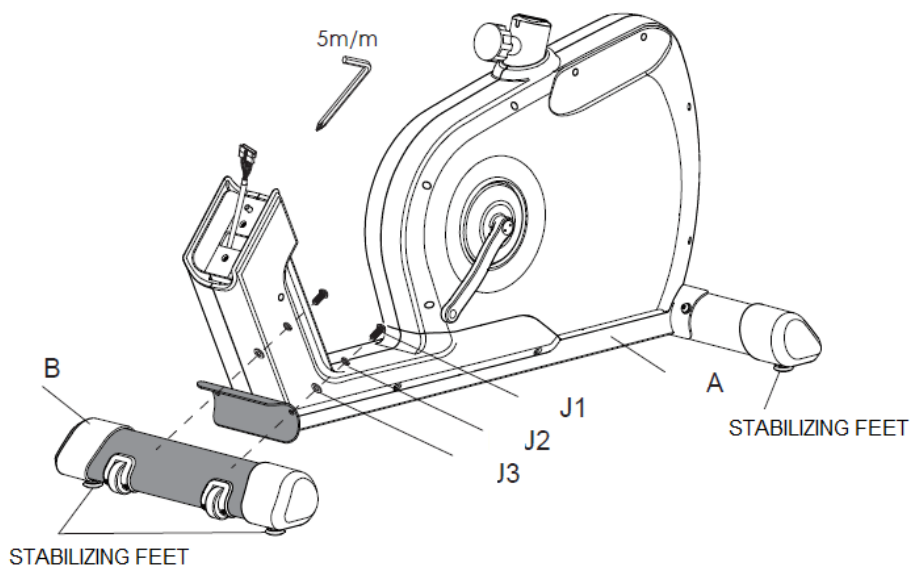

STEP 3

Ask another person to connect the cables.

Connect the cable (A1) and cable (D1), making sure they are properly connected. (Be careful not to pinch cables between frame and post)

Place the middle post (D) on the main frame (A) and connect with a 6 mm Allen key using a screw (J4) and washer (J5).

Place the plastic cover (D2) on the middle post (D).

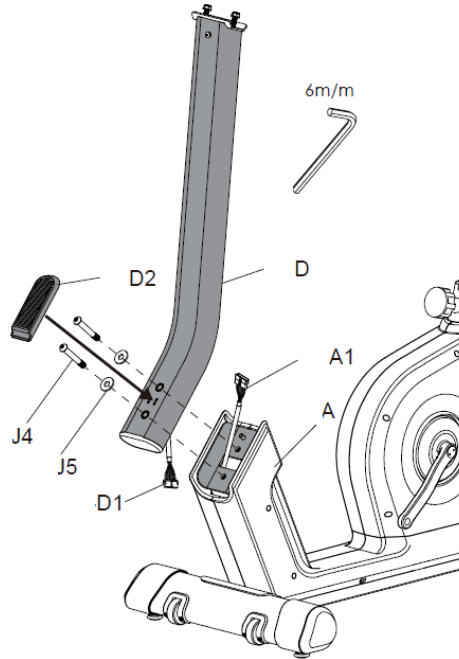

STEP 4

Remove the nut (J6) and washer (J7) from the middle post (D).

Attach handle (E) with washer (J7), nut (J6) and 13mm wrench.

Remove the screws (J8) from the middle post (D).

Using a screwdriver, attach the bottle holder (L1) to the middle post (D) with screws (J8)

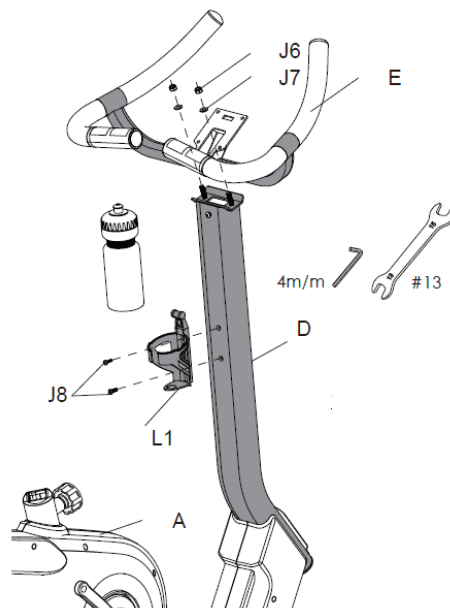

STEP 5

Remove the 4 screws (G1) on the back of the console (G)

Connect the cables (D1, E1) and the pulse measurement cable to the console.

Gently slide the console into the bracket be careful not to pinch the cables. Insert any excess cables in the middle pillar. Use a screwdriver to tighten the console.

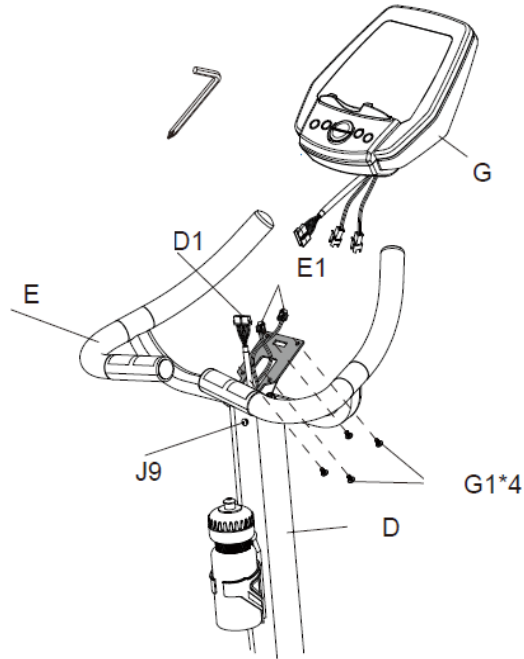

STEP 6

Remove the two screws (J9) on the middle post (D).

Attach the two plastic covers (D3 and D4) to the middle post (D) with the screws (J9) and screwdriver.

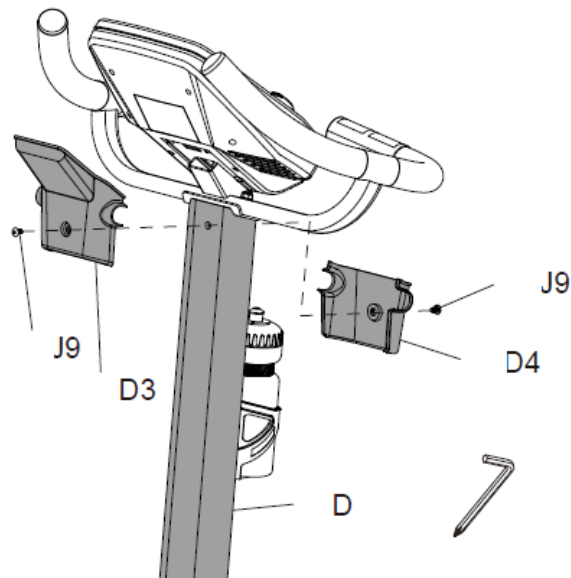

STEP 7

Remove the nuts (H1) and washers (H2) from the seat (H).

Place the seat (H) on the seat post (F1) and secure with the nut (H1) and washer (H2).

Loosen the screw (A2) and adjust the desired seat position. Then tighten the screw again.

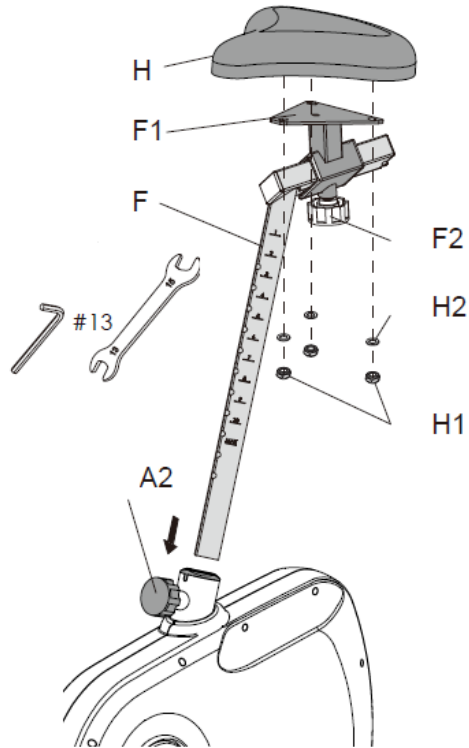

Seat adjustment

Adjust the saddle position with A2 and F2 screws.

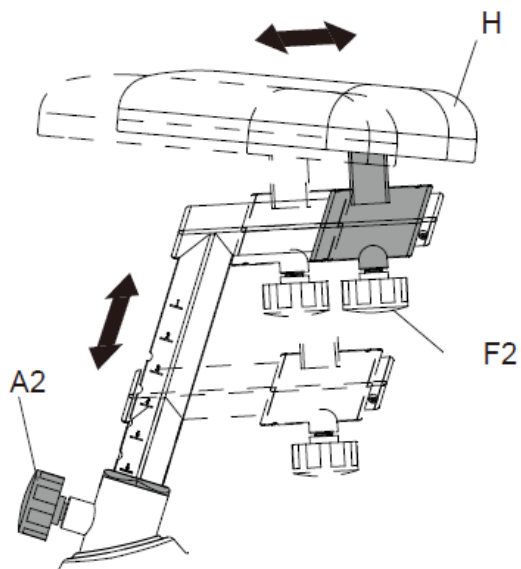

STEP 8

Attach the pedals marked L (left) and R (right).

Attach the left pedal (K1) counterclockwise. Attach the right pedal (K2) clockwise. Attach and adjust the pedal tapes as required by the user.

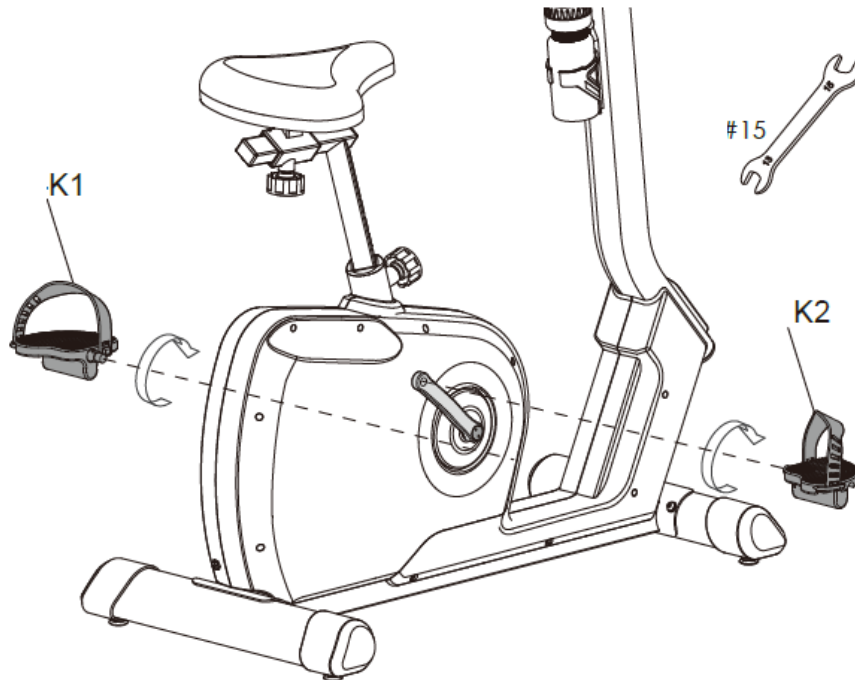

TRANSPORT



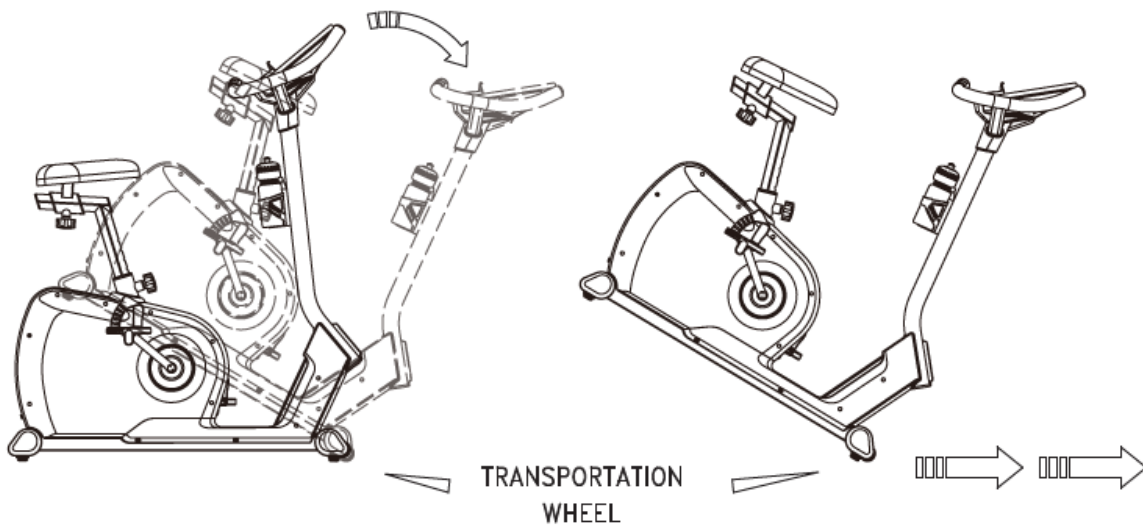

Ask another adult person for help. Lift the exercise bike by the rear stabilizer and place the exercise bike on the front transport wheels. Slowly move the exercise bike. Stabilize with stabilizing feet after transfer.



CONSOLE



BUTTONS

	UP	Increase value or resistance
	DOWN	Decrease value or resistance
	ENTER (press)	Confirm settings
	START/STOP	Press the button to start / stop program
	RESET	To reset the current program settings, it is necessary to have the program selected. Hold down the button for 2 seconds to reset all values.
	RECOVERY	Run a heart rate recovery program.

DISPLAY

TIME	Display time from 00:00 to 99:00, increase by 1 min
SPEED	Displays current speed, maximum 99.9 km / h (mph)
RPM	Displays rpm from 0 to 100 rpm
DISTANCE	Displays the distance from 00: 0 to 99.9 km (miles). The user can set the target distance by turning the knob, the value change is 0.1 km (miles).

CALORIES	Displays calories burned from 0 to 990 calories. The value change is 10 calories. The data are for guidance only, not for medical purposes.
PULSE	Displays a pulse from 0-30 to 230.
WATTS	Displays power from 0 to 999.

TURN ON

Make sure that the device is connected to the power supply, press RESET for 2 seconds, the LCD display will light up, 78.0 will be displayed and an sound signal will sound (fig. 1, 2).

You can turn the knob to select user U1 - U4 and press ENTER to confirm (fig. 3, 4). Then set the user information: sex, age, height, weight (Fig. 4 - 7).

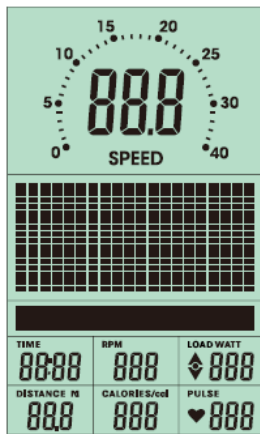

1

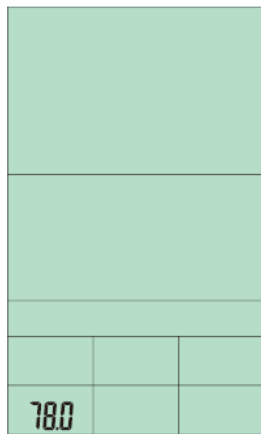

2

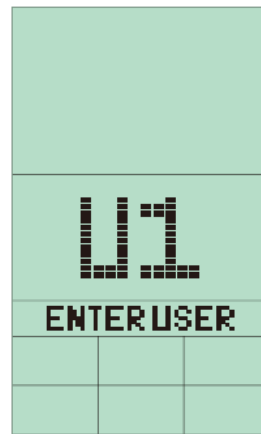

3



4



5

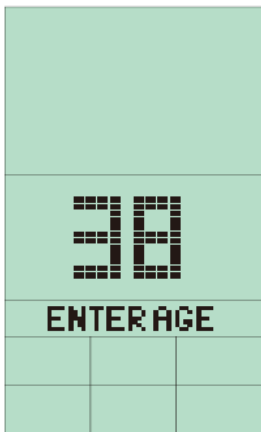

6

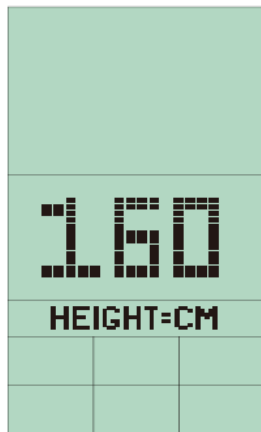

7

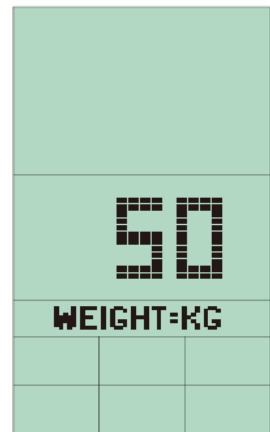

7

PROGRAM SELECTION

The programs are in the following order: manual - program (preset programs) - user program - H.R.C (heart rate program) - WATT (power program).

Use the rotary knob to select a program and press ENTER to confirm. Or press START / STOP to start the MANUAL program.



8

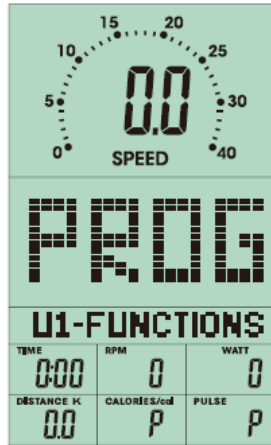

9

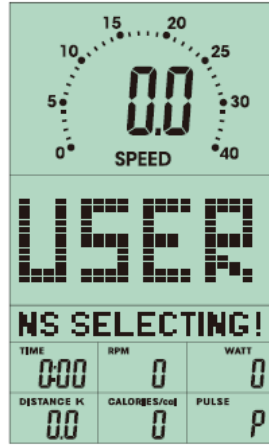

10

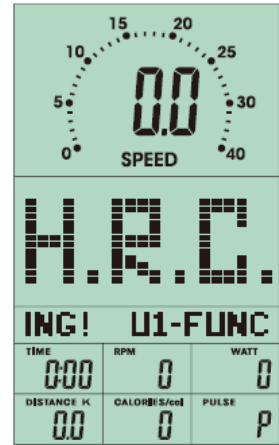

11



12

QUICK START MANUAL PROGRAM

Press ENTER to enter the MANUAL program; the display will flash (fig. 13).

Press START / STOP to start the program; you can set the resistance during exercise (Fig. 14).

Press the START / STOP button to stop the program.



13

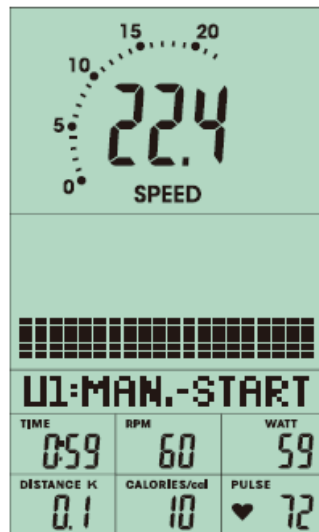

14

MANUAL MODE

Select MANUAL (Fig. 13) using the rotary knob (1 to 16) and press ENTER to confirm.

The user can set the target time, distance, calories, pulse, and press START / STOP to start the program.

Press RESET to return to the settings.

Resistance can be adjusted during exercise.

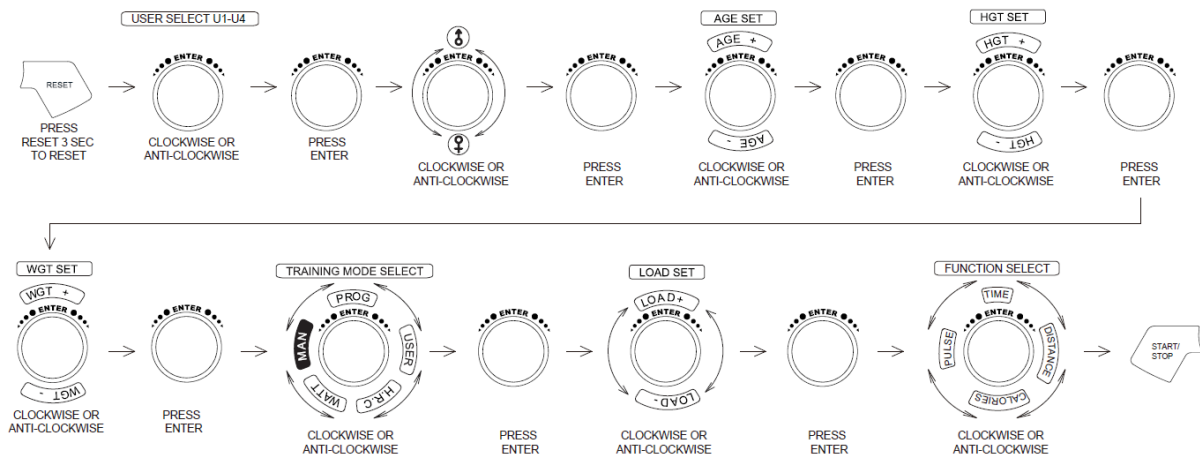
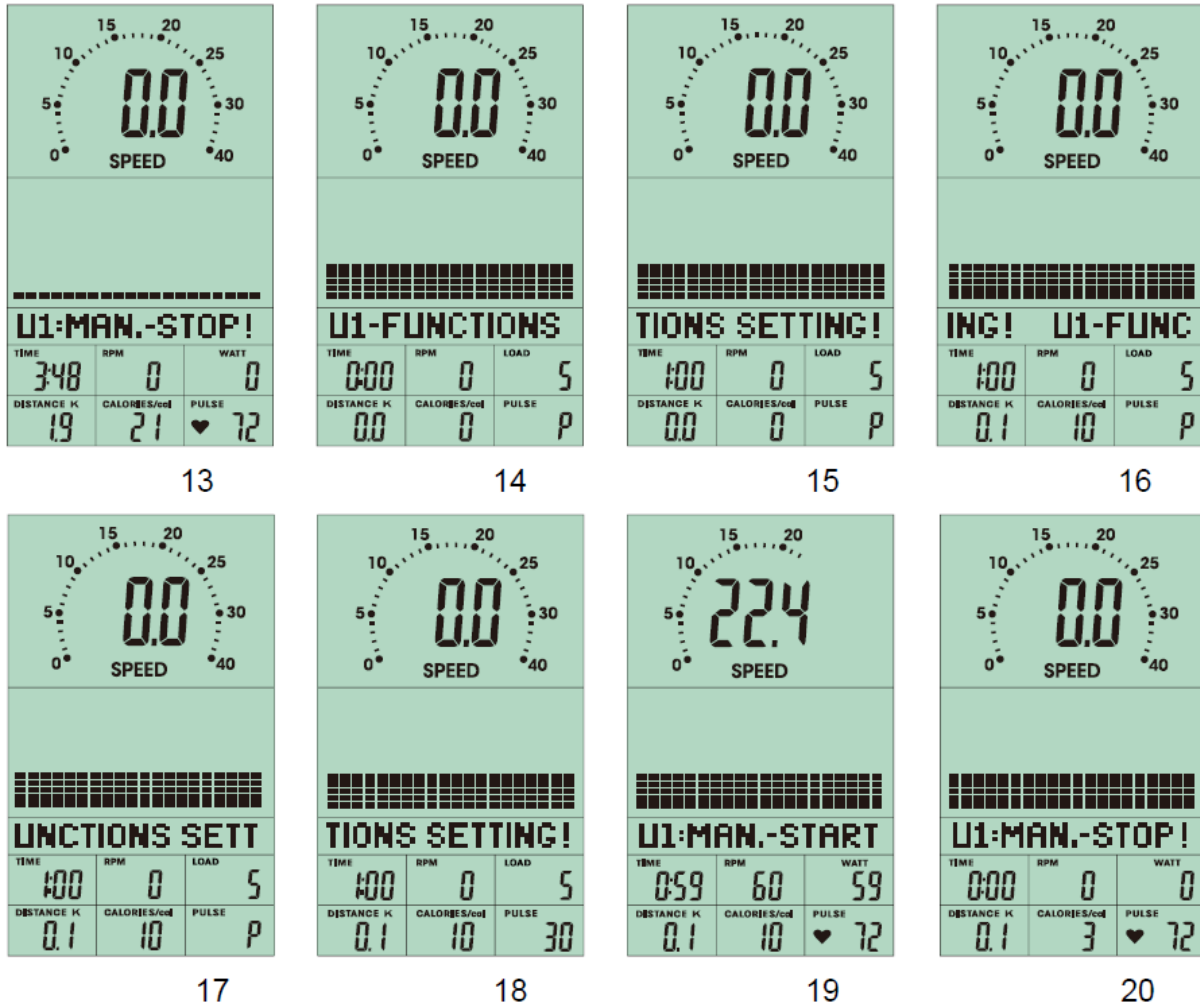

PROGRAM (preset programs)

After entering the settings, use the rotary knob to select program P1 - P12, press ENTER to confirm.

You can set the training time, press START / STOP to start the program.

After starting, the time will be subtracted from the set value. When the time reaches 0, a sound signal sounds, press any button to turn off the sound signal.

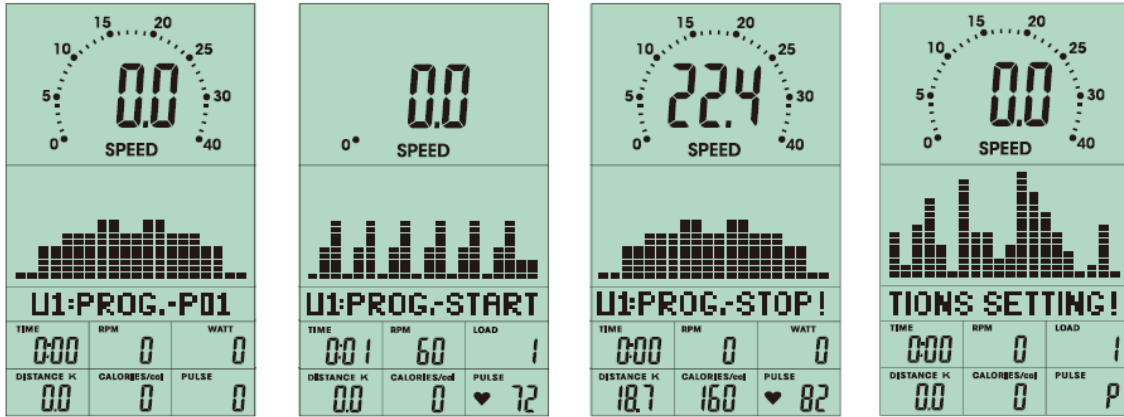

21

22

23

24

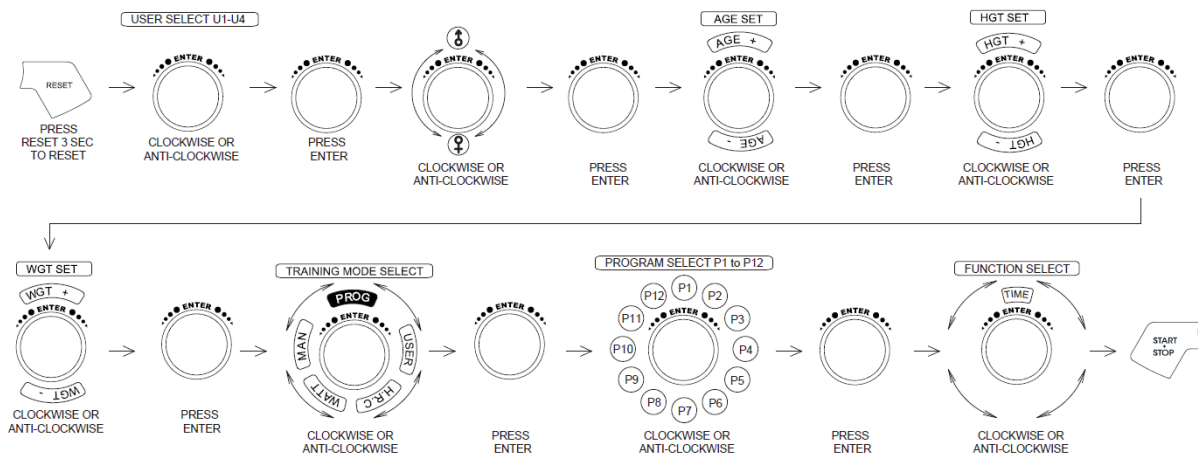
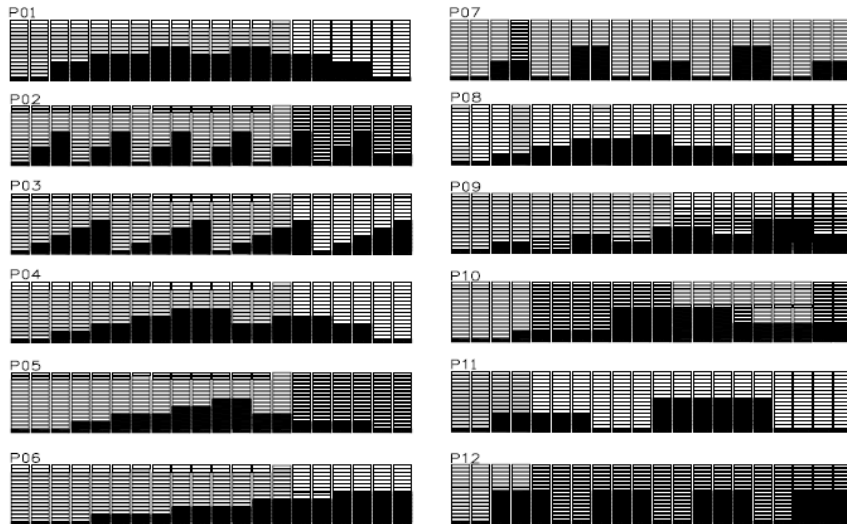

USER PROGRAM

After entering the user program settings, the user profile will flash (fig. 25), turn the knob to set the resistance (fig. 26) for the given program.

After setting 20 program segments, press MODE for 2 seconds to exit the setting and set the time.

While creating a profile, press RESET to return to the main menu.

After starting the program (Fig. 27 - 29), the time will count down. When the time reaches 0, the display will flash, and a sound signal will sound. Press any button to turn off the sound signal.

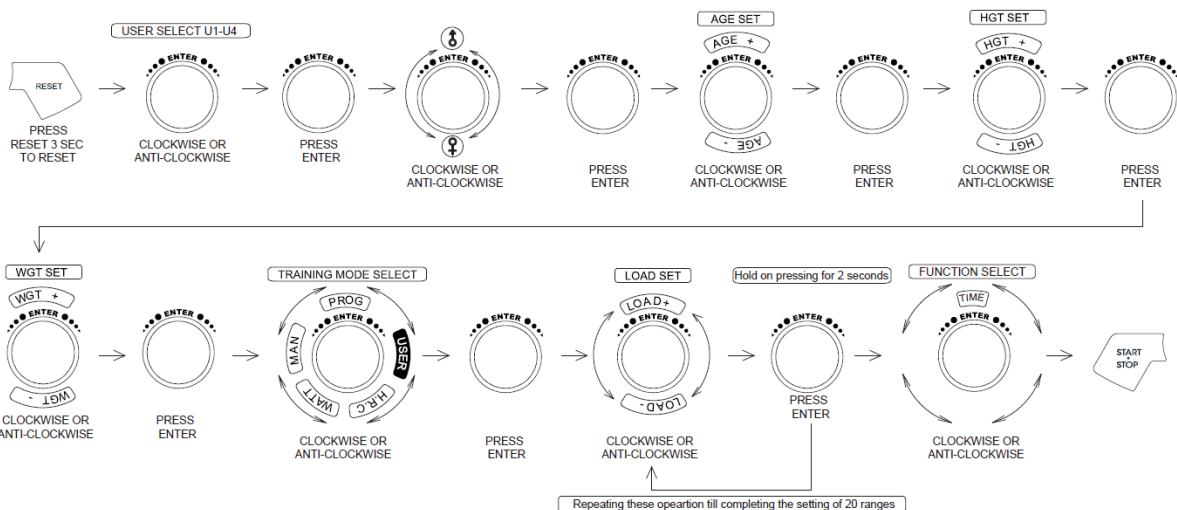
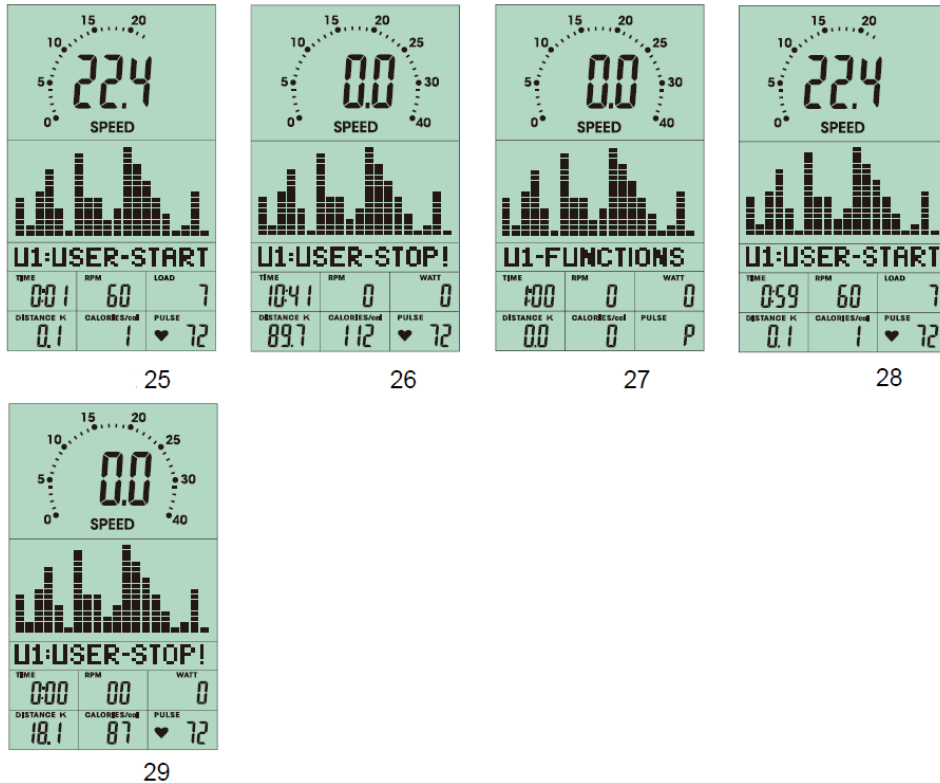

HEART RATE CONTROL

After entering the program, the user can choose% target heart rate, 55%, 75%, 90% and custom. To select, turn the knob and press ENTER.

The user can set the training time and then press START / STOP to start the program.

After starting the program, the time will count down. When the time reaches 0, the display will flash, and a sound signal will sound. Press any button to turn off the sound signal.

If the device cannot detect a pulse, the display will show .

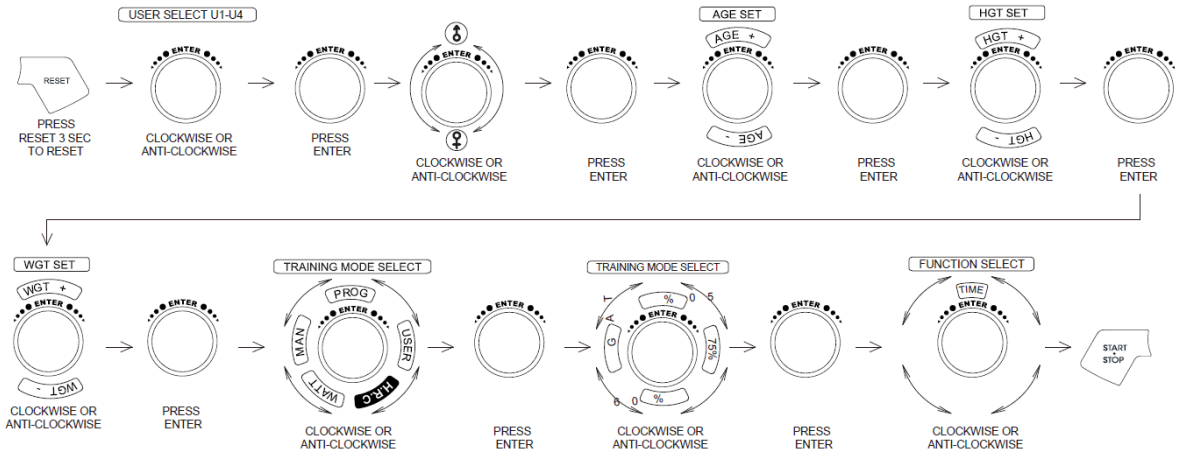
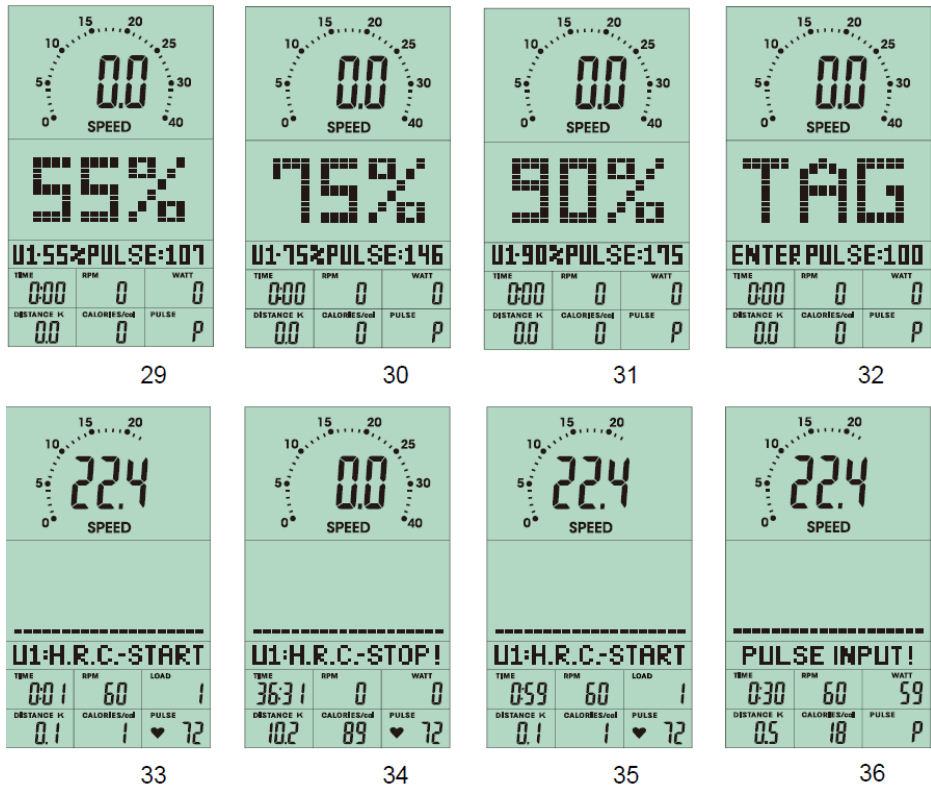

WATT CONSTANT

In standby mode, select WATT and press ENTER.

The preset value 120 will flash, use the rotary knob to set the value from 10 to 350 and press START to start the program.

The user can set the training time, press START / STOP to start the program.

After starting the program, the time will count down. When the time reaches 0, the display will flash, and a sound signal will sound. Press any button to turn off the sound signal.

The value can be adjusted during training:

	Current value > 25% of set value - slow down
---	--

●	Actual value = 25% of set value - maintain speed
▼	Current value <25% of set value – speed up



37



38

RECOVERY

After exercising, hold the sensors on the handrails and press RECOVERY.

The time countdown starts from 00:60 to 00:00.

The result from F1 to F6 is displayed, where F1 is the best result and F6 the worst result.

Press the RECOVERY button to return to the main menu.



39

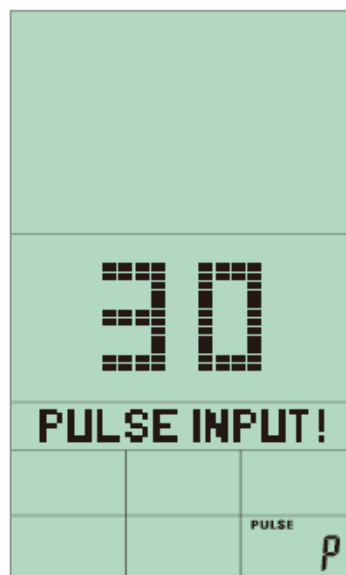

40

NOTES:

If no action is taken for 4 minutes, the console enters sleep mode, any action wakes the console.

The console is powered by a 9V, 1A adapter.

If you notice abnormal console behavior, disconnect and reconnect the adapter.

USE

Exercise on the exercise bike is based on very simple movements, but you will surely fall in love with them. Thanks to simplicity of the exercise on the exercise bike in can be done by elderly people. Prior to exercise, it is necessary to adjust the height of the saddle. It is important that you sit comfortably. The bicycle saddle must be set so that you can hold the ergonomically shaped handles when sitting. You should not have fully extended hands. You can damage your muscles.

To ensure a comfortable and comfortable exercise, put your feet on the pedal. Nowadays, all modern pedals are equipped with straps for fastening and stabilizing of the foot. It is important for your foot to be firmly and safely positioned during exercise.

The basis of exercising on a bicycle is that the legs are moving on a specific elliptical path. This movement is very similar to cycling. When doing exercise on a bicycle, you just sit on the saddle with the right height, keep your feet firmly in the pedals, hold the ergonomically shaped handles and exercise.

It is advisable at the beginning to choose a lower load. If you exercise at regular intervals on an exercise bike, you can gradually increase the load. You can increase the load gradually over a week or two weeks. Selecting a high load during the start of training can lead to rapid fatigue and muscle damage.

When exercising, it's important to choose the right load and the right tempo. Try to keep it throughout the exercise. It is not recommended to choose a high pace right from the start. Increase tempo after about a week of regular exercise. The high pace is not equal to the faster burning of calories. Correct calorie burning is reflected in an appropriate and regular exercise. At the beginning of the exercise, the number of burned calories may seem low, but regular and appropriate exercise is the key to achieving the best results.

Exercise on the exercise bike also leads to the formation of muscles. It is mainly used to strengthen the thigh and calf muscles. While exercising on a bicycle, you also move your buttocks.

If you want to exercise right, you should not forget to breathe properly. Proper and regular breathing is recommended in any exercise. It is important to keep regular deep inhales and exhales. Regular and proper breathing during exercises on the exercise bike involves intense exercise of the abdominal muscles. It is advisable to practice 30-35 after consuming food. Failure to do so may result in less calories burned, and in older age even lead to digestive problems.

For best results, you should also consider your diet. It is recommended to start a day of eating sweet food and pastries or muesli with milk. For lunch is recommended to eat a caloric richer meal. Do not forget about the soup. In the evening, light meals are recommended. If you want to improve your health, it's not just a regular exercise but a whole diet.

Bicycle exercise is an effective exercise for all busy people. Exercise on the exercise bike is effective in strengthening muscles, especially thighs, calves and buttocks. Regular exercise can lead to a slimmer figure. Exercise is recommended not only as a winter training for cyclists but also for people who want to burn excess calories. Regular breathing, regular exercise, reasonable tempo, and balanced diet can lead to your desired results.

CORRECT BODY POSTURE

When training, keep your body upright, or you can learn your hand on your forearms. During pedaling, you should not have your legs fully extended. Your knees should be slightly bent when fully pressing down the pedal. Keep your head straight with your spine to minimize the pain of the cervical muscles and upper back muscles. Always exercise fluently and rhythmically.

MAINTENANCE

- When assembling, tighten all screws and adjust the bike to the horizontal position.
- Check the screws after 10 hours of use.
- Wipe the sweat after the exercise. Clean the device with a cloth and gentle cleanser. Do not use solvents or aggressive cleaners on the plastic parts.
- When noise is increased, it is necessary to check that all joints are tightened properly.
- Place the product in a clean, ventilated and dry room.
- Do not expose the device to direct sunlight.

STORAGE

Keep the exercise bike in a clean and dry environment. Make sure the power switch is turned off and the exercise bike is not plugged into the power socket.

IMPORTANT NOTICE

- This exercise bike comes with standard safety regulations and is only suitable for home use. Any other use is prohibited and may be dangerous to users. We are not responsible for any injury caused by improper and forbidden use of the machine.
- Consult your doctor before starting training on the exercise bike. Your doctor should evaluate whether you are physically fit to use the machine and how much effort you are able to undergo. Incorrect exercise or switching of the body can harm your health.
- Carefully read the following tips and exercises. If you experience pain, nausea, breathing, or other health problems during exercise, immediately stop the exercise. If the pain persists, contact your doctor immediately.
- This exercise bike is not suitable as a professional or medical purpose. It can also not be used for healing purposes.
- The heart rate monitor is not a medical device. It provides only approximate information about your average heart rate, and any suggested pulse rate is not medically binding. Accumulated data may not always be accurate regarding uncontrollable human and environmental factors.

ENVIRONMENT PROTECTION

After the product lifespan expired or if the possible repairing is uneconomic, dispose it according to the local laws and environmentally friendly in the nearest scrapyards.

By proper disposal you will protect the environment and natural sources. Moreover, you can help protect human health. If you are not sure in correct disposing, ask local authorities to avoid law violation or sanctions.

Don't put the batteries among house waste but hand them in to the recycling place.

TERMS AND CONDITIONS OF WARRANTY, WARRANTY CLAIMS

General Conditions of Warranty and Definition of Terms

All Warranty Conditions stated hereunder determine Warranty Coverage and Warranty Claim Procedure. Conditions of Warranty and Warranty Claims are governed by Act No. 89/2012 Coll. Civil Code, and Act No. 634/1992 Coll., Consumer Protection, as amended, also in cases that are not specified by these Warranty rules.

The seller is SEVEN SPORT s.r.o. with its registered office in Borivojova Street 35/878, Prague 13000, Company Registration Number: 26847264, registered in the Trade Register at Regional Court in Prague, Section C, Insert No. 116888.

According to valid legal regulations it depends whether the Buyer is the End Customer or not.

“The Buyer who is the End Customer” or simply the “End Customer” is the legal entity that does not conclude and execute the Contract in order to run or promote his own trade or business activities.

“The Buyer who is not the End Customer” is a Businessman that buys Goods or uses services for the purpose of using the Goods or services for his own business activities. The Buyer conforms to the General Purchase Agreement and business conditions.

These Conditions of Warranty and Warranty Claims are an integral part of every Purchase Agreement made between the Seller and the Buyer. All Warranty Conditions are valid and binding, unless otherwise specified in the Purchase Agreement, in the Amendment to this Contract or in another written agreement.

Warranty Conditions

Warranty Period

The Seller provides the Buyer a 24 months Warranty for Goods Quality, unless otherwise specified in the Certificate of Warranty, Invoice, Bill of Delivery or other documents related to the Goods. The legal warranty period provided to the Consumer is not affected.

By the Warranty for Goods Quality, the Seller guarantees that the delivered Goods shall be, for a certain period of time, suitable for regular or contracted use, and that the Goods shall maintain its regular or contracted features.

The Warranty does not cover defects resulting from (if applicable):

- User's fault, i.e. product damage caused by unqualified repair work, improper assembly, insufficient insertion of seat post into frame, insufficient tightening of pedals and cranks
- Improper maintenance
- Mechanical damages
- Regular use (e.g. wearing out of rubber and plastic parts, moving mechanisms, joints etc.)
- Unavoidable event, natural disaster
- Adjustments made by unqualified person
- Improper maintenance, improper placement, damages caused by low or high temperature, water, inappropriate pressure, shocks, intentional changes in design or construction etc.

Warranty Claim Procedure

The Buyer is obliged to check the Goods delivered by the Seller immediately after taking the responsibility for the Goods and its damages, i.e. immediately after its delivery. The Buyer must check the Goods so that he discovers all the defects that can be discovered by such check.

When making a Warranty Claim the Buyer is obliged, on request of the Seller, to prove the purchase and validity of the claim by the Invoice or Bill of Delivery that includes the product's serial number, or eventually by the documents without the serial number. If the Buyer does not prove the validity of the Warranty Claim by these documents, the Seller has the right to reject the Warranty Claim.

If the Buyer gives notice of a defect that is not covered by the Warranty (e.g. in the case that the Warranty Conditions were not fulfilled or in the case of reporting the defect by mistake etc.), the Seller is eligible to require a compensation for all the costs arising from the repair. The cost shall be calculated according to the valid price list of services and transport costs.

If the Seller finds out (by testing) that the product is not damaged, the Warranty Claim is not accepted. The Seller reserves the right to claim a compensation for costs arising from the false Warranty Claim.

In case the Buyer makes a claim about the Goods that is legally covered by the Warranty provided by the Seller, the Seller shall fix the reported defects by means of repair or by the exchange of the damaged part or product for a new one. Based on the agreement of the Buyer, the Seller has the right

to exchange the defected Goods for a fully compatible Goods of the same or better technical characteristics. The Seller is entitled to choose the form of the Warranty Claim Procedures described in this paragraph.

The Seller shall settle the Warranty Claim within 30 days after the delivery of the defective Goods, unless a longer period has been agreed upon. The day when the repaired or exchanged Goods is handed over to the Buyer is considered to be the day of the Warranty Claim settlement. When the Seller is not able to settle the Warranty Claim within the agreed period due to the specific nature of the Goods defect, he and the Buyer shall make an agreement about an alternative solution. In case such agreement is not made, the Seller is obliged to provide the Buyer with a financial compensation in the form of a refund.



SEVEN SPORT s.r.o.

Registered Office:	Borivojova 35/878, 130 00 Praha 3, Czech Republic
Headquarters:	Delnicka 957, 749 01 Vitkov, Czech Republic
Warranty & Service Centre:	Cermenska 486, 749 01 Vitkov, Czech Republic
CRN:	26847264
VAT ID:	CZ26847264
Phone:	+420 556 300 970
E-mail:	eshop@insportline.cz reklamace@insportline.cz servis@insportline.cz
Web:	www.insportline.cz

SK

INSPORTLINE s.r.o.

Headquarters, Warranty & Service centre:	Elektricka 6471, 911 01 Trencin, Slovakia
CRN:	36311723
VAT ID:	SK2020177082
Phone:	+421(0)326 526 701
E-mail:	objednavky@insportline.sk reklamacie@insportline.sk servis@insportline.sk
Web:	www.insportline.sk

Date of Sale:

Stamp and Signature of Seller: