



**USER MANUAL – EN**

**IN 19141 Vibration Platform VibroGym inSPORTline Alex**



# CONTENTS

- SAFETY INSTRUCTIONS..... 3
- PRODUCT DESCRIPTION ..... 5
- ASSEMBLY ..... 6
- WARNINGS ..... 8
- PRODUCT INSTALLATION ..... 9
- CONTROL PANEL ..... 10
  - BUTTONS ..... 10
- USE ..... 11
  - General use (manual mode) ..... 11
  - Time mode (countdown) ..... 11
  - High/Low modes ..... 11
  - Preset programs (P01 – P18) ..... 11
  - Program profiles ..... 12
  - User programs ..... 12
- MAINTENANCE ..... 13
- TROUBLESHOOTING ..... 13
- DIAGRAM ..... 16
- PARTS LIST ..... 17
- ENVIRONMENT PROTECTION ..... 17
- TERMS AND CONDITIONS OF WARRANTY, WARRANTY CLAIMS ..... 18

## SAFETY INSTRUCTIONS

Please follow the warnings and cautions said below strictly. This will prevent to damage of your machine or any harm to your body or any lose which caused by any improper use of the machine. Read the manual carefully before first use and keep it for future references. Read the manual carefully and keep it for future reference.

When use the machine, please follow to the instructions.

- Please make sure that the power plug does not get pressed by the side of the machine.
- The power plug might get damaged leading to electrocution or fire.
- Use the power outlet for the machine only.
- Connecting multiple products to an outlet might lead to fire. Fuse might get damaged or the product may not function.
- Please remove dirt on the power plug using dry clothes.
- Dirt and abnormal connection might lead to fire.
- Leave 20cm of gap from the wall when installing the machine.
- Good air circulations will prevent the product from malfunctioning. For safety keep distance of 0,6 m around the device.
- Please install the product in solid and horizontal ground.
- Noise and vibration might be created when the ground level is not horizontal. Please adjust the machine when the ground is not even.
- After using the machine, please press the Stop button. Step down from the machine when the machine stops completely.
- Stepping down during run state might lead to physical injuries.
- Please unplug the power plug when the product is not in use.
- This will prevent unnecessary wastage of electricity and may prevent fire.
- Please do not run-on top of the machine when the product is in use.
- The product might get damaged.
- Old people and children should be accompanied by guardians in using the machine.
- Physical injuries might be caused.
- The machine cannot take load of more than two people. Maximum weight limit is **120 kg**.
- The machine might get damaged.
- Before cleaning, unplug the device, remove any water particles using dry clothes to prevent water particles entering the machine.
- Water particles will weaken the insulation will lead to electric leakage and fire and easy to rot the machine.
- Please clean the surface of the machine using proper cleaners suitable for the material.
- Please wipe the surface with dry clothes when wet towel had been used to clean the surface.
- Please clean and dry the machine before storing the machine for a long time.
- Please clean the surface with dry clothes before storing to prevent corrosion.
- Please do not unplug and plug the power plug with wet hands. It might lead to electrocution.
- Do not band the power cord and avoid the power cord from getting damaged by heavy items.
- When damaged, it might be led to fire.

- Please do not use damaged power cord or plug.
- It might lead to fire or electrocution.
- Do not install the machine in wet place or near to water.
- It might lead to electric leakage. The machine may get corroded when used in wet place or place nearby water.
- Please do not stock items on top of the plate.
- It might lead to electrocution or fire and may damage the electric circuit.
- Do not sprinkle water or clean the machine using gasoline, benzene, thinner or chlorine.
- There is danger of getting electrocution or catching fire. It also might damage the electronic circuit.
- Please remove the power plug before cleaning
- For prevention of electric leakage.
- When the machine creates smoke or burning smell, remove the power cord immediately and stop exercising.
- It might lead to fire or electrocution.
- Please do not disassemble, repair, or modify the machine if you are not professional.
- Non-compliance will lead to product damage or financial damage due to fire or malfunctioning of the machine.
- **Overall machine dimensions:** L77 x W76 x H148 cm
- **Size of vibrating surface:** L72,5 x W48 cm
- **Maximum load:** 120 kg
- **Equipment weight:** 48 kg
- **Category:** HB according to EN 957) suitable for home use.

If you are under medical treatment or any of the following symptoms. Please consult your doctor before use.

- Epilepsy
- Diabetes
- Heart and vascular disease
- Slipped disc or had Back/Spine Surgery
- Knee and hip implants
- Pacemaker
- Recently insert IUD, Metal pins
- Tumor
- Recent infections
- Recent operative wounds
- Pregnant women
- Severe migraine

# PRODUCT DESCRIPTION

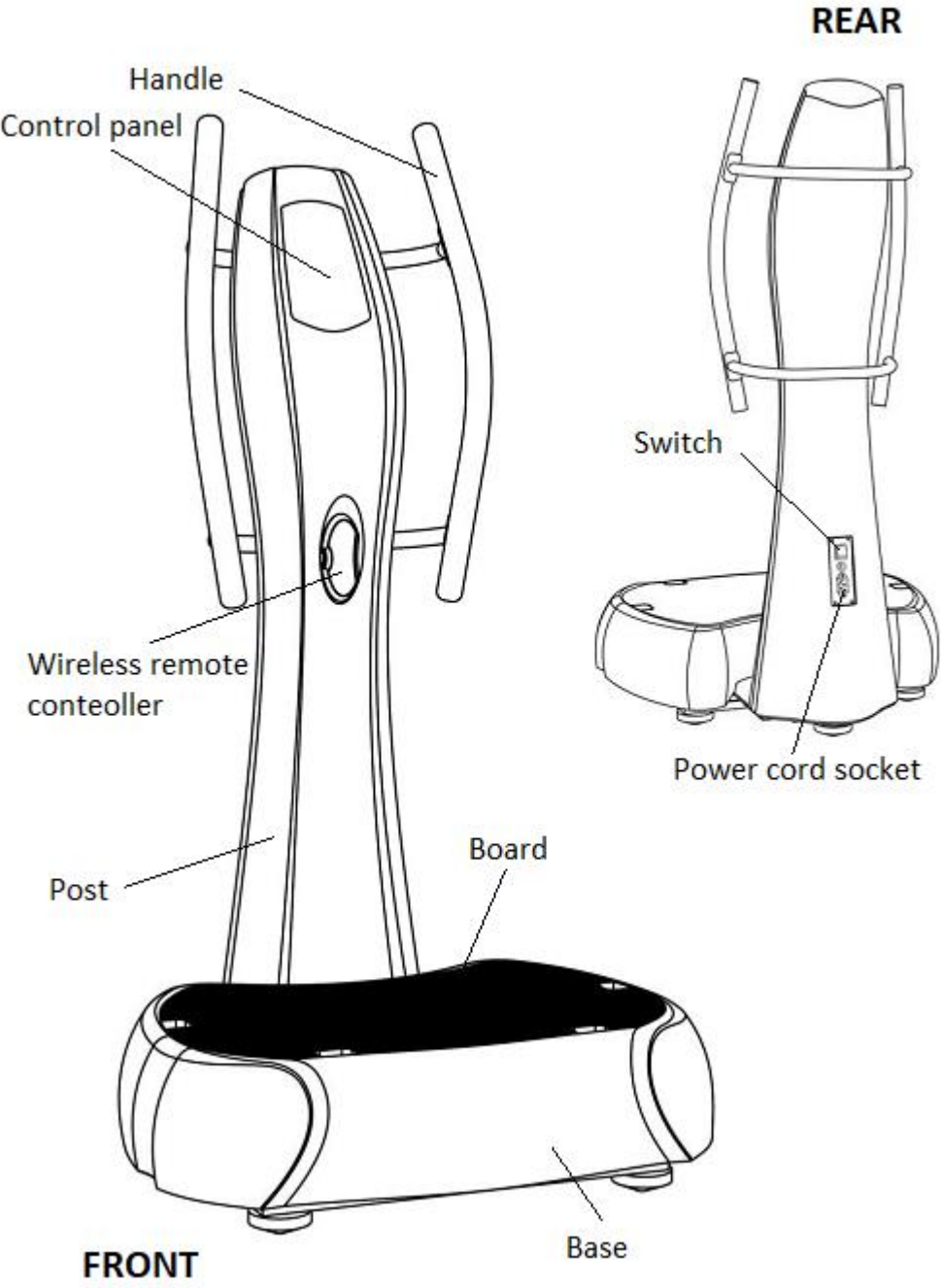

# ASSEMBLY

## Step 1

Open the box and lay out all parts.



## 2 : Tool & nuts & washer



- ① Spanner
- ② nut
- ③ Washer
- ④ Spring washer

**Step 2**

Attach the post to the base (pic. 1) and connect the cables (pic. 2). Ask another person for help.



**Picture 1**

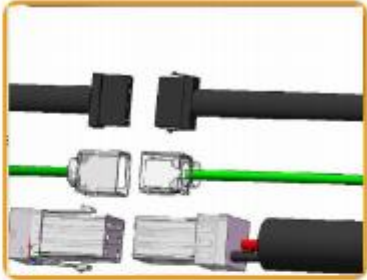

**Picture 2**



**Step 3**

With washers and nuts attach the base with the post. Ask another person for help.













## WARNINGS

This part is about user safety use. Read this part carefully and use the device properly.

	Follow the instruction or you are risking injury.
	Follow the instruction or you are risking injury.
	This product is designed for AC 220V, 50Hz / 60Hz.
	Do not use in these conditions.
	Do not disassemble or repair the machine.
	Do not touch.











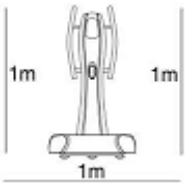

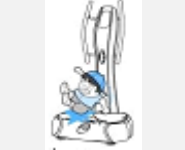

**Pay attention to the power supply, energy and method of use.**

		Do not use damaged or faulty electrical sockets and plugs.
		Use AC 220V, 50Hz / 60Hz power supply. Do not use an extension cord with multiple outlets.
		Do not touch the power supply with wet hands.
		Remove water or dust from the el. cable with a clean dry cloth.
		Do not store the vibrating machine near heat sources or open flames.



# PRODUCT INSTALLATION

## WARNING

		<p>Place the machine at a distance of min. 1 m from all walls and furniture.</p>
		<p>Place the machine on a flat surface.</p>
		<p>Do not attempt to disassemble or repair the device yourself.</p>
		<p>Children or the elderly must be supervised when exercising on this machine.</p>
		<p>Do not allow children to move near the device when it is operating.</p>
		<p>Do not use the machine if it is wet.</p>
		<p>Never place your hands, feet or any other part of your body under the machine.</p>

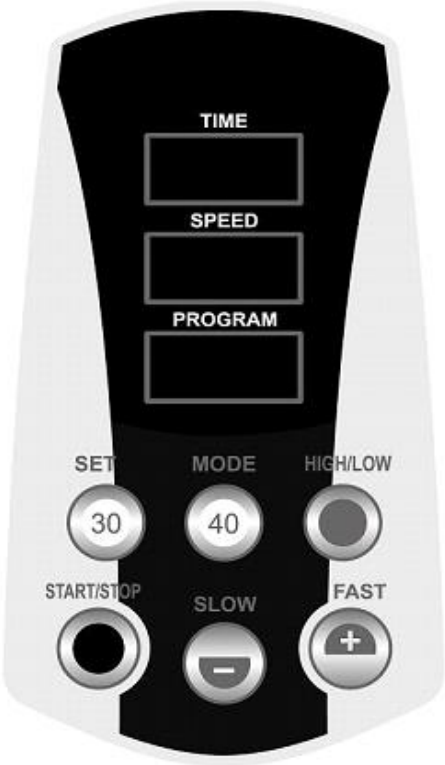

# CONTROL PANEL



<b>TIME</b>	Time is displayed from 00:00 to 10 min	
<b>SPEED</b>	When turned on displays Lo, If you push HIGH/LOW button, it changes to Hi	
	Speed displays from L15.00 to L60.0(Lo mode) Or H15.0 to H60.0 (Hi mode) during workout	
<b>PROGRAM</b>	When turned on, default program is manual	
	When the display flashes you can select one of 18 programs and 3 user programs. P01 – P18, PU01 – PU03 (PU01 is displayed after P18).	

## BUTTONS

	<b>START/STOP</b> – press to turn on or off the device.
	<b>During exercise:</b> Press to increase vibration. <b>After exercise:</b> Press to increase value of selected program.
	<b>During exercise:</b> Press to decrease vibration. <b>After exercise:</b> Press to decrease value of selected program.

	<p><b>During exercise:</b> Press to set vibration to 30 Hz.  <b>After exercise:</b> Press the button to set the value of the selected mode, e.g., time</p>
	<p><b>During exercise:</b> Press to set vibration to 40 Hz.  <b>After exercise:</b> Press to change mode.  <b>Order of modes:</b> TIME → SETUP USER PROGRAM → PROGRAM/USER PROGRAM → TIME.</p>
	<p><b>During exercise:</b> it is not active.  <b>After exercise:</b> You can change the amplitude by pressing the button.  This button is used to reset the time.</p>

## USE

### General use (manual mode)

1. Plug the machine to the socket.
2. Turn on the power switch, the machine will beep. The console will light up and TIME will flash.
3. Press **START/STOP** and adjust the speed with **FAST/SLOW**.
4. To finish exercise press, **START/STOP**.

The device stops automatically after 10 minutes - using the device for a long periods of time could be harmful to users.

### Time mode (countdown)

1. Plug the machine to the socket.
2. Turn on the power switch, the machine will beep. The console will light up and TIME will flash.
3. With buttons **FAST/SLOW** set time. Time can be set from 10 seconds to 10 minutes, in 10 seconds intervals.
4. Confirm time by pressing **SET**.
5. Press **START/STOP** and set speed with **FAST/SLOW** buttons.
6. The countdown will start.
7. When the countdown reaches 0 the device will start beep and stops.
8. During exercise you can stop the exercise with **START/STOP** button.
9. If you want to reset timer, press **HIGH/LOW**.

### High/Low modes

You can choose High or Low amplitude before pressing start button.

### Preset programs (P01 – P18)

1. Plug the machine to the socket.
2. Turn on the power switch, the machine will beep. The console will light up and TIME will flash.
3. Press **MODE** and hold until **PROGRAM** is displayed and shows P01.
4. Use **FAST/SLOW** buttons to choose programs **P01 - P18**.
5. Press **SET** to confirm selected program.

6. Press **START/STOP** to start program.
7. During preset program you cannot adjust speed.
8. Length of the program is:

**P01 ~ P06:** 5 levels, 1 minute/level – total time 5 minutes.

**P07 ~ P12:** 7 levels, 1 minute/level – total time 7 minutes.

**P13 ~ P18:** 9 levels, 1 minute/level – total time 9 minutes.

**PU01 ~ PU03:** 7 levels, 1 minute/level – total time 7 minutes.

The user can create their own programs.

9. As soon as the program ends, the device stops automatically.
10. At any time during the exercise, you can end the exercise with the **START / STOP** button.

## Program profiles

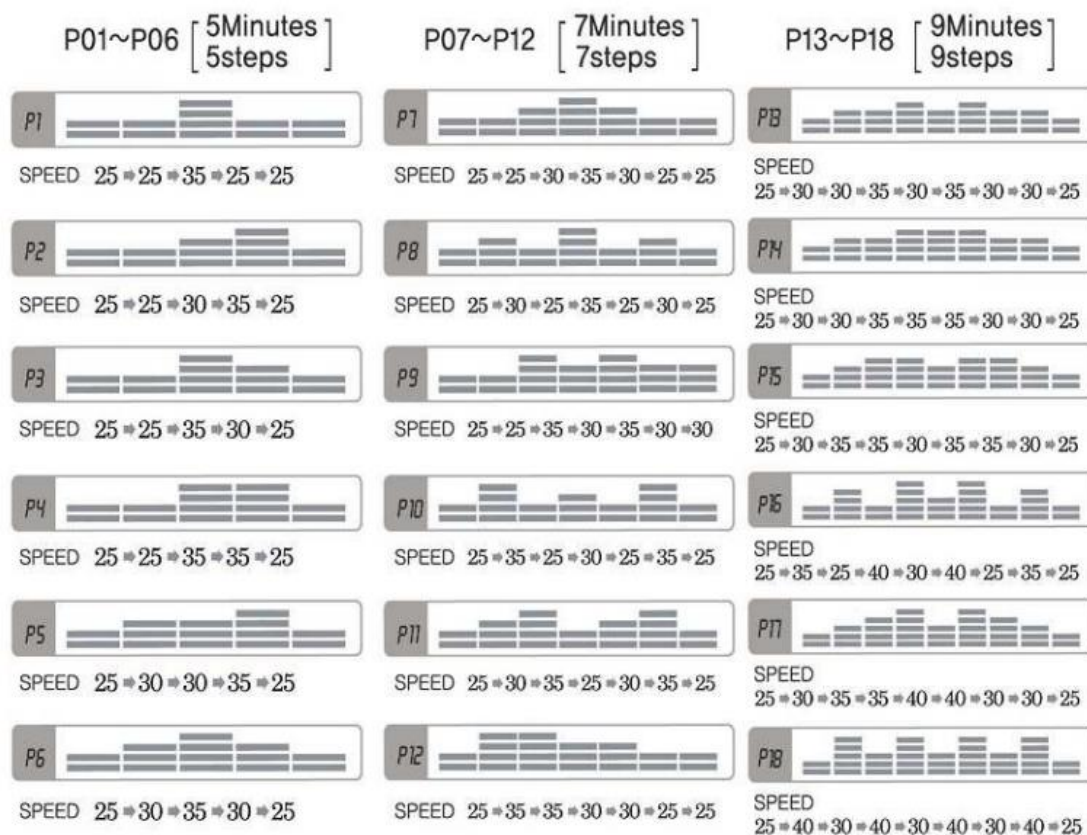

## User programs

1. Plug the machine to the socket.
2. Turn on the power switch, the machine will beep. The console will light up and **TIME** will flash.
3. Press and hold **MODE** button, until **PROGRAM** is displayed and shows **PU01**.
4. Use **FAST/SLOW** buttons to select user programs **PU01 - PU03**.
5. Press **SET** to confirm selected program.
6. On **PROGRAM** display will be displayed „1 25“. Number „1“ is interval, and number „25“ is speed of each interval. User programs has 7 intervals and speed can be adjusted on each. You cannot change the speed during exercise.

7. Use **FAST/SLOW** buttons to adjust speed of each interval. Press **SET** to confirm. At the end of each interval, information about the next interval will appear on the display. You should complete all 7 intervals in each user program. Set up the user program before attempting to start the exercise.
8. You should select the program mode to use the user programs. Press and hold the **MODE** button until **P01** appears on the PROGRAM display.
9. Use the **FAST/SLOW** buttons to select the user program **PU01 - PU03**, **PU01** will appear after **P18**.
10. Press the SET button to confirm the setting.
11. Press the **START/STOP** button to start the user program.
12. Vibration speed cannot be changed during exercise. To end the selected program, press the **START/STOP** button again.

## MAINTENANCE

- Please turn off the main power switch on the device and unplug the power cord before performing daily maintenance.
- Do not use formaldehyde or other organic impregnating agents to clean the machine.
- Please use a soft, dry cloth instead of a damp cloth to clean the main power switch and control panel.
- It is dangerous if liquid gets on the machine.
- If the supply cord is damaged, it must be replaced by the manufacturer or its service agent or a similarly qualified person to avoid a hazard to electric shock.

Carry out maintenance of the machine on a regular basis, based on the use of the machine, but at least after every 20 hours of use.

Maintenance includes:

- Check that all moving parts of the machine (axles, joints that move, etc.) are sufficiently lubricated, if not, lubricate them immediately. We recommend regular oil for bicycles and sewing machines or silicone oils.
- regular inspection of all parts - bolts and nuts and regular tightening,
- use only soap solution and not abrasive cleaners to clean the device,
- Protect your computer from damage and contact with liquids.
- the computer, adapter, plug and the entire device must not come into contact with water.
- Do not expose the computer to direct sunlight.
- Always store the machine in a dry and warm place.

## TROUBLESHOOTING

Problem	Solution
The machine is noisy during operation.	Tighten all bolts.
Nothing appears on the display.	Check the power supply.
The display is lit, but the machine is not working.	The voltage may be low
The machine is not in a vertical position to the ground.	Adjust the adjustable feet under the base.

# EXERCISES

## Thigh muscles, shins and calves

- Step on middle of mat and set your leg apart a little bit.
- Bend your knee 20-80 degree.
- Bend knee should not go forwarder than toe.
- Strengthen your back and neck then keep this posture.



## Posterior thigh muscles

- Put your one leg on mat.
- You should put your entire sole of mat.
- Lie down on ground and put your feet on the middle of mat.
- You should put your entire sole of foot on mat.
- Lie down on ground and put your feet on the middle of mat.
- Lift your waist as much as you can



## Trapezoidal muscles and forearm muscles

- Place both hands on the mat at arm's length.
- The shoulders should be horizontal to the position of the hands.
- Place the feet close to the machine.
- Lift your heels off the ground and bend your arms.
- The shoulders should be horizontal with the position of the hands.



## Abdominal muscles, tailor muscle and thigh area

- Sit on the mat and bend your legs.
- Stand on the mat and touch the ankle.
- Hug the post with your thighs, then strengthen your thighs on a mat (you strengthen the belt).
- Feel the tension in your abdominal muscles and hold your position.

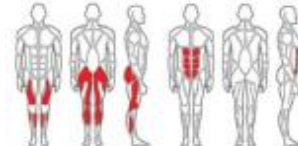

## Anterior thigh muscle

- Sit on a mat and strengthen your back.
- Lie on your side and place your thigh on the mat (there should be a right angle between the waist and the thigh).

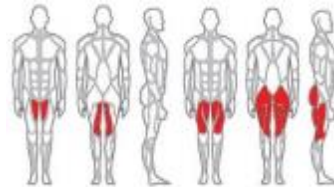

## Additional exercises:



DIAGRAM

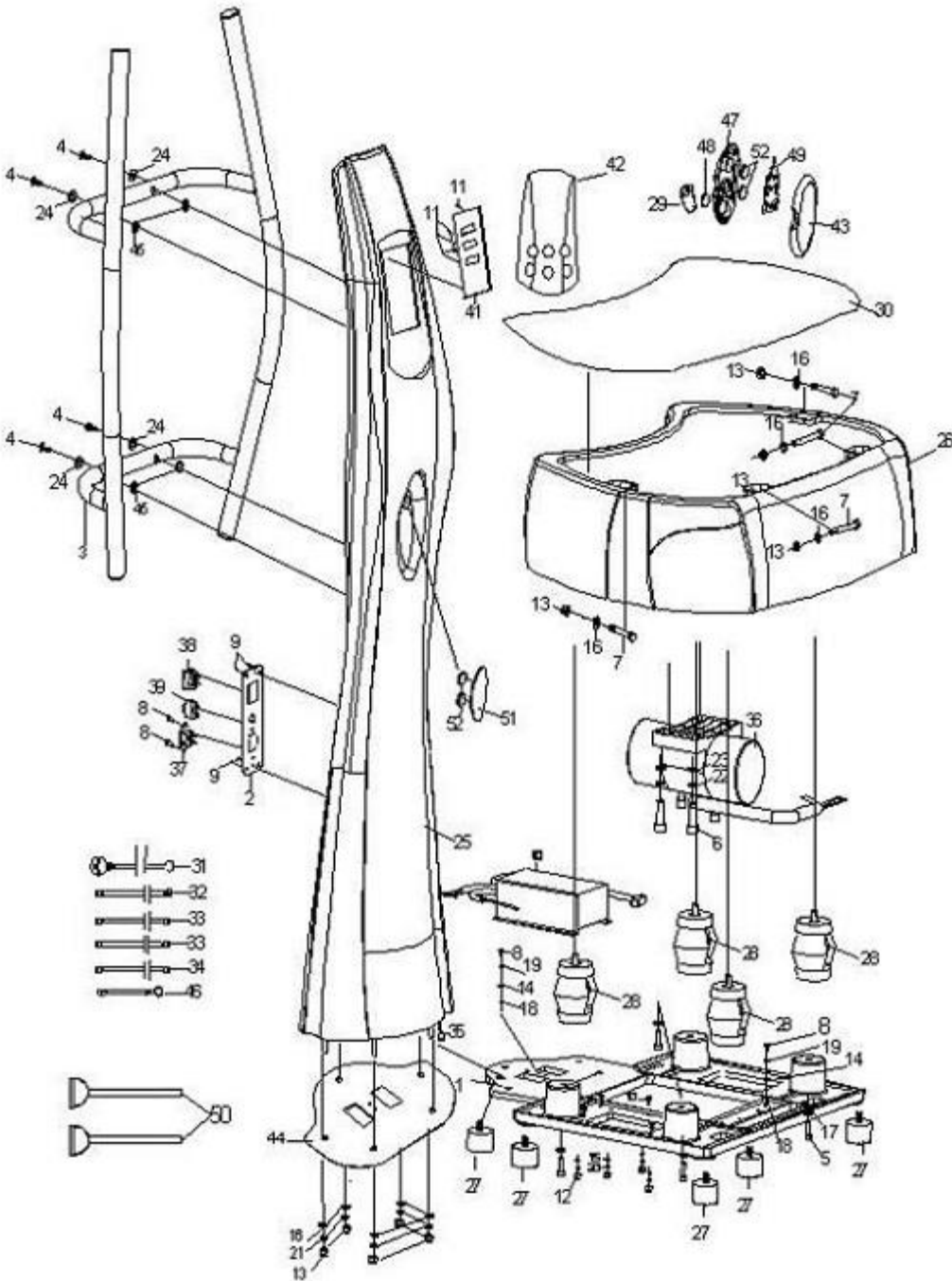



## PARTS LIST

No.	Name	Qty.	No.	Name	Qty.
1	Bottom steel frame	1	27	Base cushion	5
2	Power board	1	28	Silent Blok	4
3	Handles	1	29	Remote controller cover	1
4	Bolt	4	30	Anti-slip mat	1
5	Bolt	4	31	Power cord	1
6	Bolt	4	32	Surge protection switch	1
7	Strap holders	4	33	cablе from switch to power socket 1	2
8	Cross bolt	4	34	cablе from switch to power socket 2	1
9	Cross bolt	4	35	Connecting the control unit to the surge protection cable	1
10	Cross bolt	4	36	Motor	1
11	Cross bolt	5	37	Socket	1
12	Nut	4	38	Main switch	1
13	Nut	9	39	Surge protection	1
14	Washer	2	40	Controller	1
15	Washer	4	41	PCB display	1
16	Washer	9	42	PCB display cover	1
17	Spring washer	4	43	Top cover of the remote control	1
18	Anti-slip washer	2	44	Rubber pad for the main column	1
19	Spring washer	2	45	Rubber pad	4
20	Spring washer	4	46	Earthing cable	1
21	Spring washer	5	47	Bottom cover of the remote control	1
22	Spring washer	4	48	Remote control battery	1
23	Plastic washer	4	49	Remote control of PCB display	1
24	Curved washer	4	50	Strap	2
25	Post	1	51	Rubber pad for remote control	1
26	Base cover	1	52	Magnet in the remote control	4

## ENVIRONMENT PROTECTION

After the product lifespan expired or if the possible repairing is uneconomic, dispose it according to the local laws and environmentally friendly in the nearest scrapyard.

By proper disposal you will protect the environment and natural sources. Moreover, you can help protect human health. If you are not sure in correct disposing, ask local authorities to avoid law violation or sanctions.

Don't put the batteries among house waste but hand them in to the recycling place.

# TERMS AND CONDITIONS OF WARRANTY, WARRANTY CLAIMS

## General Conditions of Warranty and Definition of Terms

All Warranty Conditions stated here under determine Warranty Coverage and Warranty Claim Procedure. Conditions of Warranty and Warranty Claims are governed by Act No. 89/2012 Coll. Civil Code, and Act No. 634/1992 Coll., Consumer Protection, as amended, also in cases that are not specified by these Warranty rules.

The seller is SEVEN SPORT s.r.o. with its registered office in Strakonická street 1151/2c, Prague 150 00, Company Registration Number: 26847264, registered in the Trade Register at Regional Court in Prague, Section C, Insert No. 116888.

According to valid legal regulations it depends whether the Buyer is the End Customer or not.

“The Buyer who is the End Customer” or simply the “End Customer” is the legal entity that does not conclude and execute the Contract in order to run or promote his own trade or business activities.

“The Buyer who is not the End Customer” is a Businessman that buys Goods or uses services for the purpose of using the Goods or services for his own business activities. The Buyer conforms to the General Purchase Agreement and business conditions.

These Conditions of Warranty and Warranty Claims are an integral part of every Purchase Agreement made between the Seller and the Buyer. All Warranty Conditions are valid and binding, unless otherwise specified in the Purchase Agreement, in the Amendment to this Contract or in another written agreement.

## Warranty Conditions

### Warranty Period

The Seller provides the Buyer a 24 months Warranty for Goods Quality, unless otherwise specified in the Certificate of Warranty, Invoice, Bill of Delivery or other documents related to the Goods. The legal warranty period provided to the Consumer is not affected.

By the Warranty for Goods Quality, the Seller guarantees that the delivered Goods shall be, for a certain period of time, suitable for regular or contracted use, and that the Goods shall maintain its regular or contracted features.

### The Warranty does not cover defects resulting from (if applicable):

- User's fault, i.e. product damage caused by unqualified repair work, improper assembly, insufficient insertion of seat post into frame, insufficient tightening of pedals and cranks
- Improper maintenance
- Mechanical damages
- Regular use (e.g. wearing out of rubber and plastic parts, moving mechanisms, joints, wear of brake pads/blocks, chain, tires, cassette/multi wheel etc.)
- Unavoidable event, natural disaster
- Adjustments made by unqualified person
- Improper maintenance, improper placement, damages caused by low or high temperature, water, inappropriate pressure, shocks, intentional changes in design or construction etc.

## Warranty Claim Procedure

The Buyer is obliged to check the Goods delivered by the Seller immediately after taking the responsibility for the Goods and its damages, i.e. immediately after its delivery. The Buyer must check the Goods so that he discovers all the defects that can be discovered by such check.

When making a Warranty Claim the Buyer is obliged, on request of the Seller, to prove the purchase and validity of the claim by the Invoice or Bill of Delivery that includes the product's serial number, or eventually by the documents without the serial number. If the Buyer does not prove the validity of the Warranty Claim by these documents, the Seller has the right to reject the Warranty Claim.

If the Buyer gives notice of a defect that is not covered by the Warranty (e.g. in the case that the Warranty Conditions were not fulfilled or in the case of reporting the defect by mistake etc.), the Seller is eligible to require a compensation for all the costs arising from the repair. The cost shall be calculated according to the valid price list of services and transport costs.

If the Seller finds out (by testing) that the product is not damaged, the Warranty Claim is not accepted. The Seller reserves the right to claim a compensation for costs arising from the false Warranty Claim.

In case the Buyer makes a claim about the Goods that is legally covered by the Warranty provided by the Seller, the Seller shall fix the reported defects by means of repair or by the exchange of the damaged part or product for a new one. Based on the agreement of the Buyer, the Seller has the right to exchange the defected Goods for a fully compatible Goods of the same or better technical characteristics. The Seller is entitled to choose the form of the Warranty Claim Procedures described in this paragraph.

The Seller shall settle the Warranty Claim within 30 days after the delivery of the defective Goods, unless a longer period has been agreed upon. The day when the repaired or exchanged Goods is handed over to the Buyer is considered to be the day of the Warranty Claim settlement. When the Seller is not able to settle the Warranty Claim within the agreed period due to the specific nature of the Goods defect, he and the Buyer shall make an agreement about an alternative solution. In case such agreement is not made, the Seller is obliged to provide the Buyer with a financial compensation in the form of a refund.

**CZ**  
**SEVEN SPORT s.r.o.**

Registered Office: Strakonická 1151/2c, Praha 5, 150 00, ČR  
Headquarters: Dělnická 957, Vítkov, 749 01  
Warranty & Service: Čermenská 486, Vítkov 749 01

CRN: 26847264  
VAT ID: CZ26847264

Phone: +420 556 300 970  
E-mail: eshop@insportline.cz  
reklamace@insportline.cz  
servis@insportline.cz

Web: www.inSPORTline.cz

**SK**  
**inSPORTline s.r.o.**

Headquarters, warranty & service center: Električná 6471, Trenčín 911 01, SK

CRN: 36311723  
VAT ID: SK2020177082

Phone: +421(0)326 526 701  
E-mail: objednavky@insportline.sk  
reklamacie@insportline.sk  
servis@insportline.sk

Web: www.inSPORTline.sk