



USER MANUAL – EN

IN 1866 Doorway Pull-Up Bar inSPORTline



CONTENTS

- SAFETY PRECAUTIONS..... 3
- PARTS LIST 3
- ASSEMBLY 4
- PULL UP EXERCISES 4
 - Pull-ups 5
 - Underhand grip 5
 - Pull up bar exercises – abdominal 5
- MAINTENANCE 5
- ENVIRONMENT PROTECTION 5
- TERMS AND CONDITIONS OF WARRANTY, WARRANTY CLAIMS..... 6

SAFETY PRECAUTIONS

- Read this manual carefully before first use and keep it for future reference.
- Use it only for intended purpose and don't do any improper modification.
- Attach the product properly and regularly check all bolts and nuts. Re-tighten if necessary.
- Regularly check it for wearing or damage. Never use damaged or worn product.
- Keep it away from children and pets. Only an adult person may assemble and use it.
- Exercise reasonably and don't overstretch yourself to avoid an injury.
- Before starting any workout consult your physician. Remark your body signal. If you feel faintly, stop immediately.
- Don't use it outdoors.
- Regularly check all metal parts if they are not going rusty.
- Do not jump on the bar.
- Don't do jerky moves or don't swing on the bar.
- For one person at the same time.
- This product must be properly attached (anchored) to a door frame. If you are not sure, ask an expert for advice.
- Make sure that the door frame is suitable for the pull-up bar. It must be sturdy to handle pull-up bar and user.
- **Door width:** 63-100 cm
- **Door frame width:** 130-150 mm
- **Intended for home use.**
- **Weight limit: 110 kg**

PARTS LIST

No.	Name	Qty.
1	Square mounting frame	1
2	Curved handles	2
3	Long handle - right	1
4	Long handle - left	1
5	Bolts - long	2
6	Nuts	4
7	Bolts - medium	2

ASSEMBLY

Attach the curved handles (2) to the square mounting frame (1) with 2x bolts (7) and 2x nuts (6).

Connect the right and left long handles (3 and 4), making sure that the handles are securely connected.

Attach the connected long handles (3 and 4) to the curved handles (2) with 2x bolts (5) and 2x nuts (6).

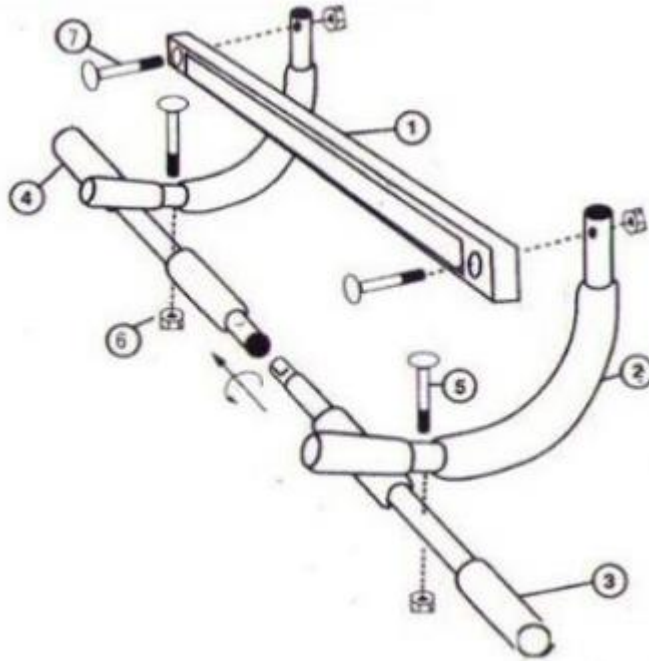

Then place the bar on the door frame.

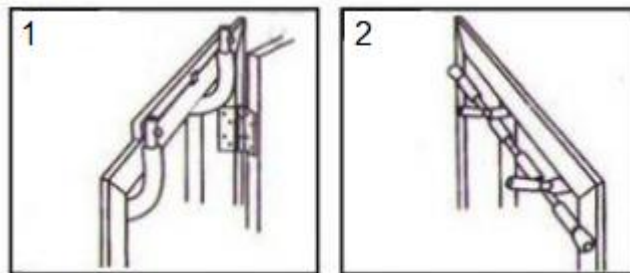

PULL UP EXERCISES

Pull ups on the bar and their various modifications are considered to be one of the best exercises to develop the upper half of the body.

The pull up bar hides a perfect home gym for exercising your body. Different variations of exercises on the bar can perfectly practice different parts of the body without having to go to the fitness centre.

When exercising on pull up bar you work with your own weight and has lower risk of injury. Of course, assuming you practice the right technique. These exercises increase the overall body strength.

Exercising involve a large amount of muscle in the upper half of the body.

Incorrect technique involves biceps and shoulders, thus keeping your back muscles unused.

During the exercise with the wrong technique, there is no development of back muscles due to insufficient load. As a result, exercise becomes ineffective.

Pull ups are the most important technique and require a slow movement. No "swing" or bending.

Pull-ups

- Narrow grip - mainly the central part of the back muscles
- Classical grip on shoulder width - mid and outside muscles are evenly used
- wide grip (recommended) - mainly the outside of the back muscles

Underhand grip

Pull up with underhand grip are designed to develop biceps. Biceps involvement can make the exercise looks easier and therefore, it is more preferred by beginners. If you want to work on the width of your back muscles, you will certainly not achieve this with "simpler" option.

Pull up bar exercises – abdominal

The abdomen can be exercise on the bar. It is a rather challenging exercise, but it is more effective in developing the abdominal muscles.

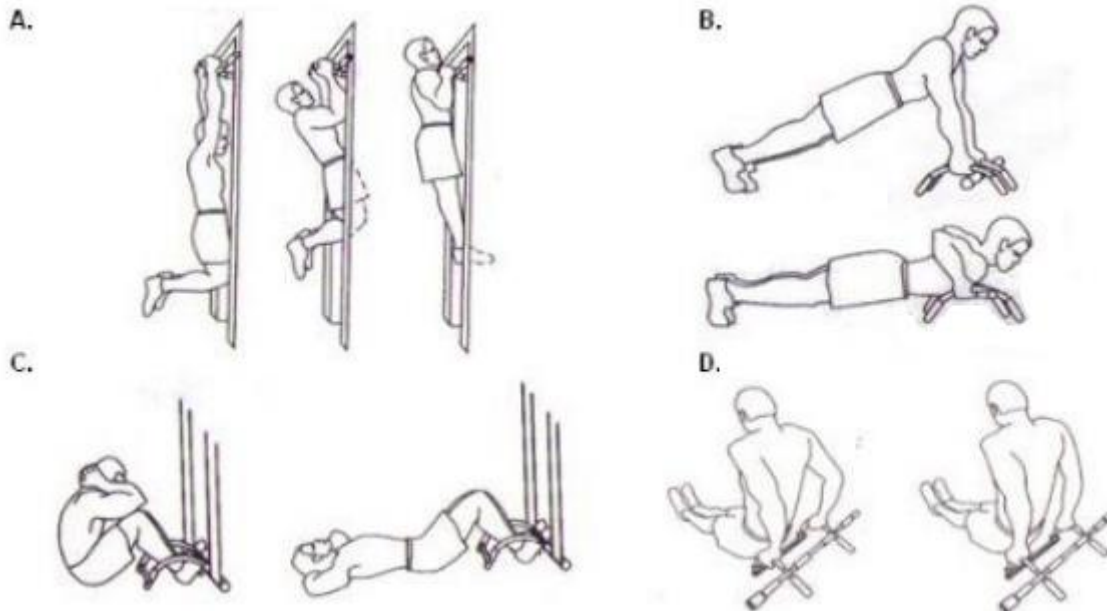

MAINTENANCE

Regular cleaning keeps the bar in good condition and prolongs its service life. After each workout, wipe the sweat surfaces with a clean, soft, damp cloth.

ENVIRONMENT PROTECTION

After the product lifespan expired or if the possible repairing is uneconomic, dispose it according to the local laws and environmentally friendly in the nearest scrapyard.

By proper disposal you will protect the environment and natural sources. Moreover, you can help protect human health. If you are not sure in correct disposing, ask local authorities to avoid law violation or sanctions.

Don't put the batteries among house waste but hand them in to the recycling place.

TERMS AND CONDITIONS OF WARRANTY, WARRANTY CLAIMS

General Conditions of Warranty and Definition of Terms

All Warranty Conditions stated here under determine Warranty Coverage and Warranty Claim Procedure. Conditions of Warranty and Warranty Claims are governed by Act No. 89/2012 Coll. Civil Code, and Act No. 634/1992 Coll., Consumer Protection, as amended, also in cases that are not specified by these Warranty rules.

The seller is SEVEN SPORT s.r.o. with its registered office in Strakonická street 1151/2c, Prague 150 00, Company Registration Number: 26847264, registered in the Trade Register at Regional Court in Prague, Section C, Insert No. 116888.

According to valid legal regulations it depends whether the Buyer is the End Customer or not.

“The Buyer who is the End Customer” or simply the “End Customer” is the legal entity that does not conclude and execute the Contract in order to run or promote his own trade or business activities.

“The Buyer who is not the End Customer” is a Businessman that buys Goods or uses services for the purpose of using the Goods or services for his own business activities. The Buyer conforms to the General Purchase Agreement and business conditions.

These Conditions of Warranty and Warranty Claims are an integral part of every Purchase Agreement made between the Seller and the Buyer. All Warranty Conditions are valid and binding, unless otherwise specified in the Purchase Agreement, in the Amendment to this Contract or in another written agreement.

Warranty Conditions

Warranty Period

The Seller provides the Buyer a 24 months Warranty for Goods Quality, unless otherwise specified in the Certificate of Warranty, Invoice, Bill of Delivery or other documents related to the Goods. The legal warranty period provided to the Consumer is not affected.

By the Warranty for Goods Quality, the Seller guarantees that the delivered Goods shall be, for a certain period of time, suitable for regular or contracted use, and that the Goods shall maintain its regular or contracted features.

The Warranty does not cover defects resulting from (if applicable):

- User's fault, i.e. product damage caused by unqualified repair work, improper assembly, insufficient insertion of seat post into frame, insufficient tightening of pedals and cranks
- Improper maintenance
- Mechanical damages
- Regular use (e.g. wearing out of rubber and plastic parts, moving mechanisms, joints, wear of brake pads/blocks, chain, tires, cassette/multi wheel etc.)
- Unavoidable event, natural disaster
- Adjustments made by unqualified person
- Improper maintenance, improper placement, damages caused by low or high temperature, water, inappropriate pressure, shocks, intentional changes in design or construction etc.

Warranty Claim Procedure

The Buyer is obliged to check the Goods delivered by the Seller immediately after taking the responsibility for the Goods and its damages, i.e. immediately after its delivery. The Buyer must check the Goods so that he discovers all the defects that can be discovered by such check.

When making a Warranty Claim the Buyer is obliged, on request of the Seller, to prove the purchase and validity of the claim by the Invoice or Bill of Delivery that includes the product's serial number, or eventually by the documents without the serial number. If the Buyer does not prove the validity of the Warranty Claim by these documents, the Seller has the right to reject the Warranty Claim.

If the Buyer gives notice of a defect that is not covered by the Warranty (e.g. in the case that the Warranty Conditions were not fulfilled or in the case of reporting the defect by mistake etc.), the Seller is eligible to require a compensation for all the costs arising from the repair. The cost shall be calculated according to the valid price list of services and transport costs.

If the Seller finds out (by testing) that the product is not damaged, the Warranty Claim is not accepted. The Seller reserves the right to claim a compensation for costs arising from the false Warranty Claim.

In case the Buyer makes a claim about the Goods that is legally covered by the Warranty provided by the Seller, the Seller shall fix the reported defects by means of repair or by the exchange of the damaged part or product for a new one. Based on the agreement of the Buyer, the Seller has the right to exchange the defected Goods for a fully compatible Goods of the same or better technical characteristics. The Seller is entitled to choose the form of the Warranty Claim Procedures described in this paragraph.

The Seller shall settle the Warranty Claim within 30 days after the delivery of the defective Goods, unless a longer period has been agreed upon. The day when the repaired or exchanged Goods is handed over to the Buyer is considered to be the day of the Warranty Claim settlement. When the Seller is not able to settle the Warranty Claim within the agreed period due to the specific nature of the Goods defect, he and the Buyer shall make an agreement about an alternative solution. In case such agreement is not made, the Seller is obliged to provide the Buyer with a financial compensation in the form of a refund.

CZ
SEVEN SPORT s.r.o.

Registered Office: Strakonická 1151/2c, Praha 5, 150 00, ČR
Headquarters: Dělnická 957, Vítkov, 749 01
Warranty & Service: Čermenská 486, Vítkov 749 01

CRN: 26847264
VAT ID: CZ26847264

Phone: +420 556 300 970
E-mail: eshop@insportline.cz
reklamace@insportline.cz
servis@insportline.cz

Web: www.inSPORTline.cz

SK
inSPORTline s.r.o.

Headquarters, warranty & service center: Električná 6471, Trenčín 911 01, SK

CRN: 36311723
VAT ID: SK2020177082

Phone: +421(0)326 526 701
E-mail: objednavky@insportline.sk
reklamacie@insportline.sk
servis@insportline.sk

Web: www.inSPORTline.sk