



**USER MANUAL – EN**

**IN 16086 Treadmill inSPORTline Gardian G6**



# CONTENTS

- SAFETY INSTRUCTIONS..... 3
- TECHNICAL PARAMETERS ..... 4
- ASSEMBLY INSTRUCTIONS ..... 5
- ASSEMBLY STEPS ..... 6
- UNFOLDING INSTRUCTIONS ..... 8
- FOLDING INSTRUCTIONS..... 8
- OPERATION INSTRUCTIONS ..... 9
  - LED DISPLAY ..... 9
- BUTTON FUNCTIONS ..... 10
- OPERATION INSTRUCTIONS ..... 11
  - MANUAL MODE ..... 11
  - COUNTDOWN MODE ..... 11
  - PRE-SET PROGRAMS ..... 11
  - USER PROGRAM ..... 13
  - PULSE TEST ..... 13
  - POWER SAVING MODE ..... 13
  - MP3..... 13
  - METRIC-INCH SYSTEM AND INCLINE ADJUSTMENT ..... 14
- ERRORS AND TROUBLESHOOTING ..... 14
- SAFETY LOCK..... 15
- POWER SAVING MODE..... 15
- MP3 PLAYER FUNCTION (OPTIONAL)..... 15
- USB FUNCTION (OPTIONAL) ..... 15
- SHUT DOWN..... 15
- WARNINGS ..... 15
- SAFE EXERCISING ..... 15
- MAINTENANCE ..... 16
  - LUBRICATION..... 16
- MIDDLE PLACEMENT OF BELT AND TIGHTNESS ADJUSTMENT ..... 16
- PLOY V-BELT (ADJUSTMENT)..... 18
- STARTING YOUR WORKOUT ..... 19
- EXERCISE FREQUENCY ..... 19
- WARM-UP PHASE ..... 19
- EXPLODED DRAWING..... 21
- PARTS LIST ..... 22
- ENVIRONMENT PROTECTION ..... 26
- TERMS AND CONDITIONS OF WARRANTY, WARRANTY CLAIMS..... 26

## SAFETY INSTRUCTIONS

Thank you for purchasing this product. Read this manual carefully before first using and keep it for future reference. Observe all warnings and precautions for your higher safety.

- Attach the safety key to your dress or belt before starting any workout.
- While exercising, swing your arms naturally, straight ahead. Don't look at your feet. Only one person may use it at time.
- Always increase and decrease your speed gradually and don't do it abruptly.
- In some emergency case, press the emergency button or pull the safety key out from its lock.
- Leave this device only after it has fully stopped.
- Observe all installation instructions. Only an adult person may assemble it.
- Keep it away from children and pets. Never let children unattended near this device. Only adults are allowed to use it.
- Consult your physician before starting any exercise program. It is especially necessary if you have some health complications or if you take a medical care or if you suffer from hypertension.
- Regularly check all bolts and nuts. They should be well tightened. Regularly check this device for damage or wear. Never use damaged or worn product.
- Regularly check the running belt for damage or wearing. If some sharp edges occur, stop using.
- Put it only on a flat, dry, solid and clean place. Keep distance of min. 0.6 m around it for higher safety. Don't use it in wet environment. Don't put it on a thick carpet that could disable its ventilation.
- If the power line is damaged, don't use it and buy a new one from an authorized seller.
- Avoid moisture and humidity.
- The treadmill shouldn't cover a convenient wall socket.
- Never remove the protective cover if this device is on. If you have to do it because of maintenance, first unplug it from socket.
- Always wear appropriate sports clothes. Avoid too loose clothes that could be easily caught in machine. Always wear sports shoes with rubber soles.
- Never start the running belt if you stand on it. After power connecting, there may be a pause until the belts starts moving. You should always stand on the plastic side non-slip rails until it begins to move.
- Don't exercise 40 mins. after having a meal.
- First warm up your body to avoid possible cramps.
- Never put any objects into plugs, sockets and compartments.
- Maintain this product regularly and according to this manual to prolong its lifespan.
- Don't do any improper modification of this treadmill.
- Exercise reasonably and don't overrate your skills. If your exercise for the first time, hold the handrails firmly until you will be familiar with correct using.
- If some damage arises, stop using immediately. If the treadmill suddenly increases or decreases its speed, pull out the safety key and stop your training.













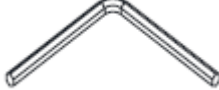

- Power it on only when its assembly has been completely finished and the motor cover is put on. Use only a socket with 16A safety grounding. We recommend use an over-current protector to assure your safety.
- Don't use it outdoors.
- **Weight limit:** 140 kg
- **Category:** HB (according to EN957 norm) suitable for home using
- **WARNING!** The heart rate frequency monitoring may not be completely accurate. Overexertion during training can lead to a serious injury or even death. If you start to feel faint, stop the exercise immediately.

## TECHNICAL PARAMETERS

<b>Assembly size (mm)</b>	2025*888*1395 mm	<b>Speed range</b>	1-18 km/h
<b>Incline</b>	0-18 levels	<b>Motor spec. (HP)</b>	4.0HP (max.)
<b>Running size (mm)</b>	520*1500 mm	<b>Input Volt (V)</b>	220-240V
<b>N.W. (kg)</b>	128 kg	<b>Output</b>	1500W
<b>Max. user weight</b>	140 kg	<b>Operating temperature</b>	0-28 °C
<b>Blue Single Display</b>	Speed, Time, Distance, Calories, Pulse		
<b>Safety protection and advantages</b>	A) Magnetic safety lock (red).		
	B) Overcurrent and overload function set in the microcomputer.		
	C) LED display window in the middle. It is clear and features a non-limited view angle coverage. Speed range: 1.0-18 km/h.		
	D) Frequency controlling method. Speed adjustment is highly smooth and convenient.		
	E) Buffer system makes your workout natural and smooth assuring the lowest impact for user feet, ankles, joints etc.		
	F) The over-current protector can continue in function only if manually reset. It protects the motor from damaging.		
	G) Intelligent explosion-proof circuit can finish working in 0.3 seconds. It offers the highest protection.		

## ASSEMBLY INSTRUCTIONS

Before starting the assembly make sure that no part is missing. See parts and tools of this device in the chart below.

			
3L/R. Upright	20. 4# Wrench	21. 6# Wrench	22. 8# Wrench
			
23. Wrench	45L/R. Left, Right Upright Cover	55. Storage box	91. Silicone oil
			
134. Screw M5*20	127. Flat Washer ø9*ø16*t1.6	135. Screw M10*45	144. Screw M8*15
			
93. Main Frame Assembly	94. Computer Assembly	81. Spring line	

## ASSEMBLY STEPS

### 1. STEP

Connect the lower power wire (100) with the power cord middle wire (99) Then put the L/R upright (3L/R) on the main frame assembly (93). Fix them with screw M10\*45 (135). Don't lock them tightly.

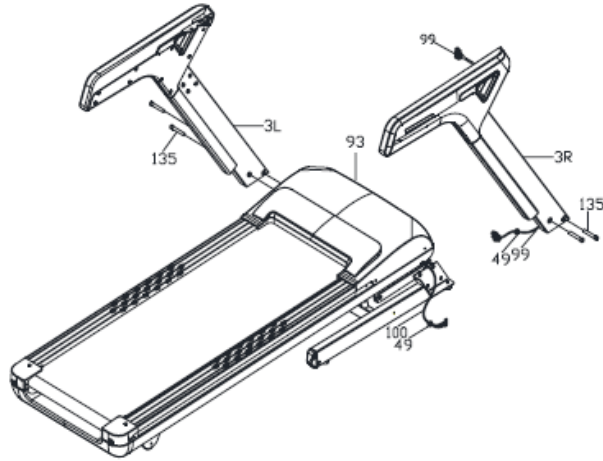

### 2. STEP

Fix the Computer assembly (94) on the upright (3L/R). Connect the power cord middle wire (99) and the Power cord upper wire (98). Use M8\*15 screw (144) and flat washer (127) to lock it.

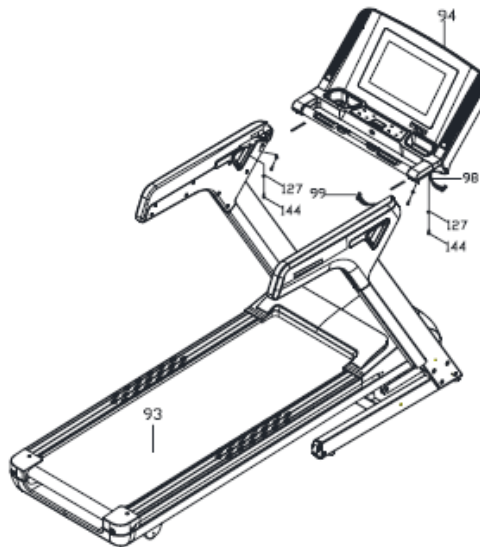

### V6 Wire connecting specification

1. Take off the computer wire cover board (right) (Pic. 1, 2). Then take out the upper wire from the computer (Pic. 3).



2. Put the middle wire into the right hole of the computer (Pic. 4, 5). Connect them (Pic. 6).



3. Then fix the computer onto the frame. Use the toolkit M6 wrench. Tighten firmly all four bolts M8\*15 with flat washers  $\varnothing 9 \times \varnothing 16 \times 1.6$  (Pic. 7, 8).

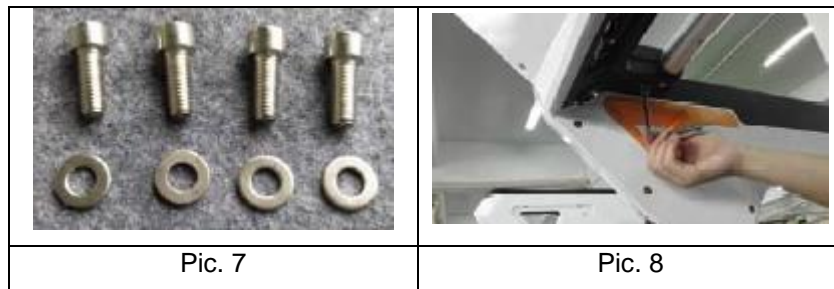

4. Thereafter put the tidy wire into the computer (meter). Assemble the removed computer wire cover board (right) back with a screwdriver (Pic. 9). At least attach the storage box (that is in the accessory box) to the meter (Pic. 10).

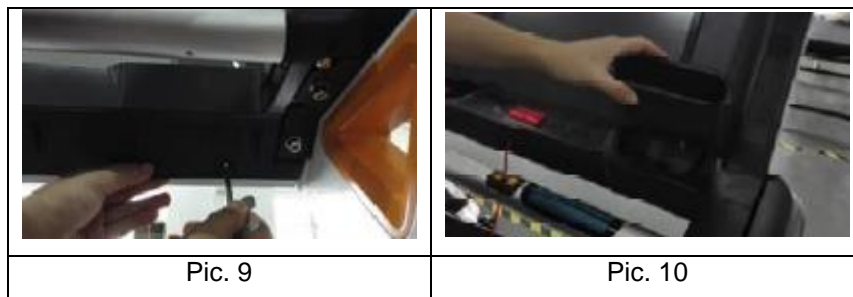

### 3. STEP

First lock tightly the M10\*45 screw (135) and then lock the L/R upright cover (45L/R) on the frame assembly with M5\*20 screw (134).

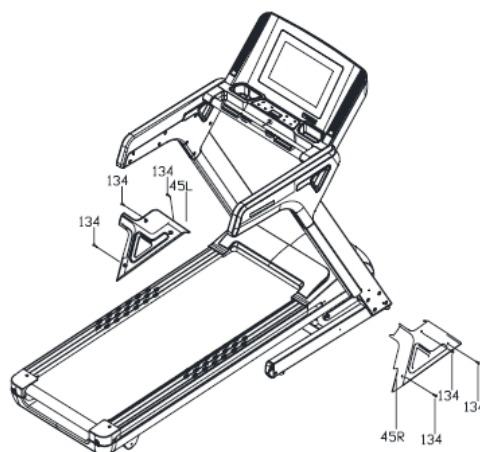

## UNFOLDING INSTRUCTIONS

Support the end of the treadmill with right hand. Then pull the knob up (don't turn it).

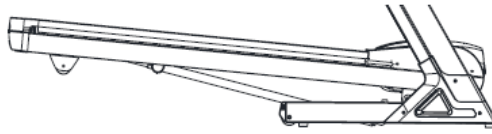

## FOLDING INSTRUCTIONS

Support the end of the treadmill with hand, until you will hear a click sound. That means the cylinder has been locked in the round tube and this device is successfully folded.

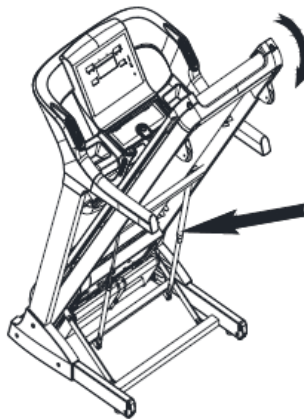



# OPERATION INSTRUCTIONS

## LED DISPLAY



### 1. TIME WINDOW

It counts and displays the running time in range from 0:00-99:59. It counts until the limit. Thereafter it starts counting from 0:00. After restarting it starts again from 0:00. It counts down from the pre-set value to zero. When the zero value is reached, this device slows down steadily and stops moving. When this treadmill stops completely, it enters the standby mode.

### 2. DISTANCE WINDOW

It displays the running distance in a forward direction while counting in the range from 0.00-99.90. When the limit is reached, it clears to zero and counts from zero again. Also, it can count down from a pre-set value to zero. When the zero value is reached, this device slows down steadily and stops moving. When this treadmill stops completely, it enters the standby mode.

### 3. PULSE WINDOW

It displays the user pulse. If the user holds the pulse handrails firmly by both hands, the system can detect the pulse rate and display it on the screen. The range is: 22-250 bpm. This result has not a medical value. It is only indicative.

### 4. BURNED CALORIES

It displays burned calories by the exerciser. It can count in a forward direction from 0 to 9999. When this limit is reached, it clears back to zero and counts from zero again. Also, it can count down from a pre-set value to zero stand. When the zero value is reached, this device slows down steadily and stops moving. When this treadmill stops completely, it enters the standby mode.

### 5. SPEED WINDOW

It displays the current speed in the operating state. The range is: 1.0-18 km/h.

### 6. INCLINE WINDOW

It displays the current incline value in the range: 0-18 levels.

### 7. MATRIX WINDOW

At the manual mode, it displays the racetrack and incline and speed in the middle. At a pre-set program, it displays changing image of speed and incline.

## BUTTON FUNCTIONS

BUTTON	FUNCTION
START	Push it once to start this treadmill.
STOP	Push it to stop this device while operating.
MODE	Button for function selection. Press it to choose: time countdown, distance countdown, calories countdown.
PROGRAMS	Circular selection of 24 pre-set programs (P1, P2, P3, P4, P5, P6, P7, P8 - --- P24) and 2 user programs.
SPEED+	Push it to increase the speed by 0.1 while exercising. Push it to increase the value while setting in time, distance, calories etc.
SPEED-	Push it to decrease the speed by 0.1 while exercising. Push it to decrease the value while setting in time, distance, calories etc.
INCLINE+	Push it during your workout to increase the incline.
INCLINE-	Push it during your workout to decrease the incline.
VOLUME START/STOP	Push to start or stop MP3 playing.
SOUND+	Increasing volume
SOUND-	Decreasing volume
FORMER MUSIC	Push it to play previous music.
NEXT MUSIC	Push it to play next music.

#### NOTE:

- Speed shortcut keys: 3, 6, 9 (km/h).
- Incline shortcut keys: 3, 6, 9 (levels).

# OPERATION INSTRUCTIONS

## MANUAL MODE

Connect the power and the computer beeps a long sound at the same time. It enters the standby mode after 2 seconds. Insert the safety key and push START button to start this device. Move it at the lowest speed. Time, calories and distance are counted in forwarding direction. Use key SPEED+/- to change your speed or key INCLINE+/- to adjust the incline.

## COUNTDOWN MODE

### TIME COUNTDOWN MODE:

- At the standby mode push the MODE button once and the time window flashes. Default time is 30. Push SPEED+/- to select the time value. You can increase or decrease the time value by 1 min. (one button press). The adjustable time range: 5:00-99:00.
- Push the START button to start it. When the time counting comes down to zero, this device stops working.
- In this mode, the speed and incline can be adjusted.

### DISTANCE COUNTDOWN MODE:

- At the standby mode push the MODE button twice and the distance window flashes. Default distance is 5.00. Push SPEED+/- to select the distance value. You can increase or decrease the distance value by 0.1 km. (one button press). The adjustable distance range: 0.50-99.00.
- Push the START button to start it. When the distance counting comes down to zero, this device stops working.
- In this mode, the speed and incline can be adjusted.

### CALORIE COUNTDOWN MODE:

- At the standby mode push the MODE button three times and the calorie window flashes. Default calorie value is 100. Push SPEED+/- to select the calorie value. You can increase or decrease the calorie value by 10 cal. (one button press). The adjustable distance range: 20-990 cal.
- Push the START button to start it. When the calorie counting comes down to zero, this device stops working.
- In this mode, the speed and incline can be adjusted.

## PRE-SET PROGRAMS

- At the standby mode push the PROGRAM button to choose from pre-set programs (P1, P2, P3 ----- P24). Program default time: 30:00. Press SPEED+/- to choose operation time. Press START key to start operating.
- When the time counts down to zero, this treadmill stops working.

Refer to program chart below:

Program/Time		Setting time 30 minutes/10=operating span									
		1	2	3	4	5	6	7	8	9	10
P1	Speed	1	1	4	3	4	3	5	4	2	5
	Incline	1	1	2	3	3	1	2	2	3	2
P2	Speed	2	5	4	6	4	6	4	2	5	2
	Incline	1	2	3	3	2	2	3	5	2	2
P3	Speed	2	5	4	5	4	5	4	4	3	2
	Incline	1	2	2	3	1	2	2	2	2	1
P4	Speed	3	6	7	5	8	5	9	6	4	3
	Incline	2	2	3	3	2	2	4	6	2	2
P5	Speed	3	6	7	5	8	6	7	6	4	3
	Incline	1	2	4	3	2	2	4	5	2	1
P6	Speed	2	8	6	4	5	9	7	5	4	3
	Incline	2	2	6	2	3	4	2	2	2	1
P7	Speed	2	6	7	4	4	7	4	2	6	2
	Incline	4	5	6	6	9	9	10	10	6	3
P8	Speed	2	4	6	8	7	8	6	2	3	2
	Incline	3	5	4	4	3	4	4	3	3	2
P9	Speed	2	4	5	5	6	5	6	3	3	2
	Incline	3	5	3	4	2	3	4	2	3	2
P10	Speed	2	3	5	3	3	5	3	6	3	3
	Incline	4	4	3	5	6	7	7	5	3	3
P11	Speed	3	5	8	8	9	5	7	6	3	2
	Incline	4	5	6	6	9	9	10	10	6	3
P12	Speed	3	5	5	4	4	6	4	2	3	4
	Incline	3	5	6	7	10	10	10	10	6	3
P13	Speed	3	5	7	8	9	10	8	5	4	4
	Incline	1	2	3	4	5	5	4	3	2	1
P14	Speed	2	4	6	8	10	10	8	6	4	2
	Incline	4	5	6	7	8	8	7	6	5	4
P15	Speed	3	4	7	8	10	9	8	6	5	4
	Incline	3	4	5	6	7	8	8	5	3	2
P16	Speed	2	3	5	4	5	5	7	5	4	2
	Incline	0	2	2	4	4	6	6	1	1	0
P17	Speed	2	6	8	3	9	4	10	4	3	2
	Incline	6	6	10	10	3	3	3	7	1	0
P18	Speed	1	5	4	5	9	5	4	5	3	2
	Incline	5	5	8	8	10	10	10	7	1	0

P19	Speed	3	4	8	4	3	8	6	4	4	1
	Incline	2	4	4	4	4	2	3	3	1	0
P20	Speed	3	2	3	6	6	6	6	5	2	2
	Incline	3	3	5	5	5	5	2	2	1	0
P21	Speed	2	6	5	6	8	6	7	4	3	2
	Incline	2	3	3	3	4	4	1	1	2	0
P22	Speed	2	4	6	8	10	8	6	4	6	6
	Incline	2	3	6	6	3	5	9	3	5	3
P23	Speed	2	4	6	8	4	2	7	8	10	1
	Incline	3	6	5	3	5	3	5	5	4	2
P24	Speed	2	4	6	4	6	8	10	8	6	4
	Incline	2	5	5	3	5	5	3	3	4	2

## USER PROGRAM

Push the PROGRAM button at the standby mode to choose a user program: U1, U2. Program default time is 30:00. Push SPEED+/- and select operation time. Push MODE button to confirm it and enter each program speed and incline setting. Push SPEED+/- to choose speed and push INCLINE+/- to select incline. Confirm by MODE key. Thereafter enter the next program setting. After finishing the setting, push START to operate. When the time reaches the zero (counting down), this treadmill stops.

## PULSE TEST

When the controller detects hand pulse, the heart rate screen will display corresponding pulse value.

**Test before exercising:** Stand onto the side rails of this treadmill with both feet. Hold the pulse-rate sensor with both hands and wait for 20 seconds. The pulse screen will display current pulse value on the pulse screen.

**Test after exercising:** Stand onto the side rails of this treadmill with both feet. Hold the pulse-rate sensor with both hands and wait for 20 seconds. The pulse screen will display current pulse value on the pulse screen.

**NOTE:** Don't do this test during a workout to have the best results.

## POWER SAVING MODE

This system features a power-saving function. This system enters the power-saving mode at the standby state after 10 minutes of no button activity. The display shuts down automatically. To wake it up, press any key.

## MP3

When the power is on, connect MP3 or another audio device and the computer can play music.

1. When SD card or U disc is inserted, the volume, song selection and pausing can be controlled by the computer.
2. When only an external MP3 is connected, then volume, song selection and pausing is controlled via the audio device.

## METRIC-INCH SYSTEM AND INCLINE ADJUSTMENT

- Push START button. Remove the safety key and insert it again. Now you can switch between the metric and the inch system. Push SPEED+/- to choose metric (SI) or inch (ENG) system (on the speed window). After selection push START to confirm it and go to standby state.
- At the standby state press SPEED+/-, INCLINE+/- keys at the same time for 3 seconds. Enter the automatic incline adjustment. After adjusting enter the standby state.

## ERRORS AND TROUBLESHOOTING

SIGN	DESCRIPTION	PROCESSING
Er-1	No reaction signal of the computer.	<ul style="list-style-type: none"> <li>• Check if the computer wire is loose or fallen out.</li> <li>• Check connection between computer and controller.</li> </ul>
Er-2	Incline system failure	<ul style="list-style-type: none"> <li>• Check the signal line of the incline motor.</li> <li>• Check if the incline motor is damaged.</li> <li>• Check if the controller is damaged.</li> </ul>
Er-3	Over-voltage protection	<ul style="list-style-type: none"> <li>• Check proper voltage of AC220-240V.</li> </ul>
Er-4	Over-current protection	<ul style="list-style-type: none"> <li>• Check if the moving parts stuck.</li> <li>• Check the lubrication. If the lubrication is insufficient, add oil.</li> <li>• Check if the running board is worn.</li> <li>• Check the motor and the controller for damage.</li> </ul>
Er-5	Over-load protection	<ul style="list-style-type: none"> <li>• Check if the moving parts stuck.</li> <li>• Check the lubrication. If the lubrication is insufficient, add oil.</li> <li>• Check if the running board is worn.</li> <li>• Check the motor and the controller for damage.</li> </ul>
Er-6	Motor is not well connected.	<ul style="list-style-type: none"> <li>• Check the correct motor connection.</li> <li>• Check the motor or controller for damage.</li> </ul>
Er-7	Failure of the controller detect signal.	<ul style="list-style-type: none"> <li>• Check connection of the computer wire.</li> <li>• Check connection between computer and controller.</li> </ul>
SAFE	Safe lock fault.	<ul style="list-style-type: none"> <li>• Check if the safe lock is in right place.</li> <li>• Check the magnetic plug.</li> </ul>
	Display doesn't work.	<ul style="list-style-type: none"> <li>• Check the power outlet.</li> <li>• Check if the power switch is on.</li> <li>• Check the socket and fuses.</li> </ul>

## **SAFETY LOCK**

In any case pull down the safety lock. The LED window will display “SAFE” and the buzzer sounds. If the motor is working it stops urgently. Safety lock is in an off state and keys are invalid.

## **POWER SAVING MODE**

This device features a power saving function. At the standby mode, if there is no button signal within 10 minutes, the system enters automatically the power save mode. The display shuts down automatically. Push any key to restart it.

## **MP3 PLAYER FUNCTION (OPTIONAL)**

When you turn on the power, connect the MP3 player or other audio equipment and computer will play music. You can adjust the sound volume using a button on the audio equipment. Don't play music too loud to avoid reducing the sound quality.

## **USB FUNCTION (OPTIONAL)**

The USB interface is on the panel. Via the USB interface you can connect an external device such as a U-disc or cell phone. If the U-disc is connected, the treadmill can play Mp3 songs. Connect the phone with charging function.

## **SHUT DOWN**

You can turn off the power to shut down the treadmill at any state without damaging this device.

## **WARNINGS**

- Check that the power and safety lock is properly connected before starting any exercise.
- Pull off the safety key to stop the treadmill immediately. Put it in again to return to the default setting.
- Never disassemble or repair it yourself. Contact an authorized service.

## **SAFE EXERCISING**

- Ask your physician for advice before starting any exercise.
- If you feel some health complications while exercising (chest tightness, chest pain, irregular heartbeat, breath shortness, dizziness etc.) stop immediately. Consult your physician before starting again.
- You can choose either a normal walking speed or jog speed. If you are not sure in proper speed, refer to the standard below:

<b>Speed in km/h</b>	<b>Description</b>
1 – 3.0	People with weak physical constitution.
3.0 – 4.5	People with a sedentary job.
4.5 – 6.0	Regular walking speed.
6.0 – 7.5	Fast walking.
7.5 – 9.0	Jogger
9.0 – 12.0	Intermediate speed runner.

12.0 – 14.5	Experienced runner.
14.5 and more	Excellent runner.

**NOTE:**

- It is advisable for a walker to choose the speed of 6.0 km/h or lower.
- It is advisable for a runner to choose the speed of 8.0 km/h or higher.

## **MAINTENANCE**

**WARNING!**

- Make sure that the power plug is pulled out before cleaning or maintaining this product.
- Clean it properly to prolong product lifespan.
- Remove dust regularly.
- Clean the exposed belt parts to prevent dust from penetrating under the running belt.
- Exercise only in shoes with clean and dry soles.
- Never put any object to sockets and compartments or between the running belt and running board.
- Clean the running belt surface using a wet soapy cloth.
- Protect it from water and liquids that could damage electric components under this belt.
- First unplug this device from electric outlet before removing the motor cover.
- Remove the motor cover and vacuum the space under this cover at least once a year.

## **LUBRICATION**

The running belt and running deck are pre-lubricated. The belt/deck friction may play a major role in the functionality and lifespan of this product. Thus, it needs periodical lubrication. We recommend do regular inspection of the deck. If it is worn, contact the service.

- Low use (lower than 3 hours per week) – once per year
- Moderate use (3-5 hours per week) – every 6 months
- Frequent use (more than 5 hours per week) – every 3 months
- Always use silicon oil inSPORTline.

**NOTE:**

- You can buy lubricating oil from your local distributor or contact the producer.
- To prolong product lifetime, we recommend powering off for 10 minutes every 2 hours of running.
- Too loose running belt can make you slip while running. Too tightened running belt can influence negatively the motor performance and speed up wearing. The optimal state is, if the running belt can be lift from the running deck about 50-75 mm.

## **MIDDLE PLACEMENT OF BELT AND TIGHTNESS ADJUSTMENT**

It is necessary to adjust the belt for better usage. Treadmill with a well-adjusted belt can work better.

Put the treadmill running belt to the centre following next steps:

- Put the treadmill on a level ground and let it run at speed of 6-8 mph (9-12 km/h). Observe deviation of the running belt. If the running belt deviates right, pull out the safety key and



unplug this device from an electric outlet. Turn the adjusting bolt on the right side clockwise by  $\frac{1}{4}$  circle. Then plug this device again and insert the safety key. Start the treadmill and let it run. Check deviation again and repeat until the belt will be in the middle (Pic. A).

- If the running belt deviates left, pull out the safety key and unplug this device from an electric outlet. Turn the left adjusting bolt clockwise by  $\frac{1}{4}$  circle. Then plug this device again and insert the safety key. Start the treadmill and let it run. Check deviation again and repeat until the belt will be in the middle (Pic. B).
- The running belt can get loose with time or because of frequent using. It should be adjusted. To do it, pull out the safety key and power it off. Turn the left and right adjusting bolt clockwise by  $\frac{1}{4}$  circle, plug this device and insert the safety key back to the lock. Let the treadmill run and stand on to confirm its tightness (Pic. C).

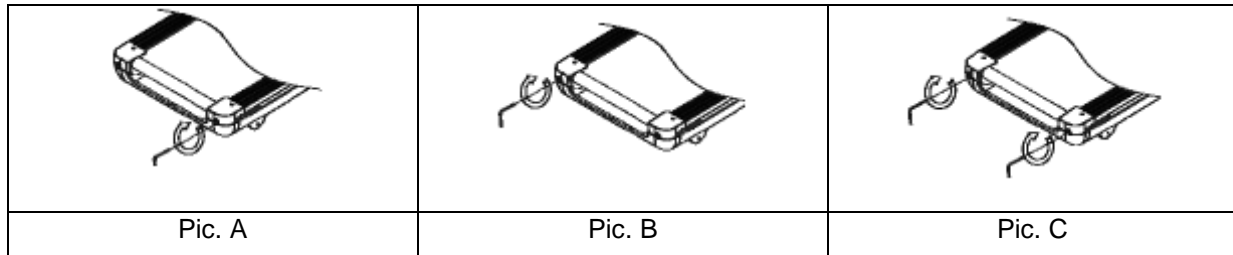

## PLOY V-BELT (ADJUSTMENT)

The Ploy-V belt can get gradually loose and can change its shape after a long-time usage. You should adjust it to increase your safety. Check if the belt is to be adjusted as described:

- If you feel some pause while your feet press on the running belt, the running belt or the V-belt is too loose. Make further test to confirm which part is loose.
- Unscrew the four screws on the motor cover and let the treadmill work at speed of 1 km/h. Stand on the running belt, hang on the handrails and try to press the belt with your feet harder than usually (use your body weight).
  - A. If the running belt doesn't stop when you press it, the running belt and the motor belt is not flabby or tight. It is a right state.
  - B. If the running belt stops, when you press it, but the motor belt and the front roller don't stop, the running belt is a little loose. To adjust the running belt, follow information on previous pages.
  - C. If the running belt and the motor belt stop when you press on the running belt and its motor still runs, the motor belt is flabby and should be adjusted.

### ADJUSTING METHOD:

1. Unscrew four bolts of the front motor protective cover and take the cover off.
2. Unscrew four bolts of the motor base, but don't remove it. Use a winch and adjust the adjusting bolt on the motor base as needed.
3. You can use your hand to reverse the motor belt that situated between motor axis and front roller. If it is too loose, you can reverse the Ploy V-Belt by 100%. If it is too tight, the turning possibility of the belt will be significantly limited. After adjusting you can reverse the motor belt by 80% to make it just right. Adjust the V-Belt so that it can turn by 80%.
4. Lock the motor base frame and assemble the motor cover.

## STARTING YOUR WORKOUT

### WARNING!

- Ask your physician for advice before starting any exercise, especially if you are older than 45 years or if you suffer from some health problems.
- Before starting using it, stand on the side and learn operate it properly. You may exercise after you are fully familiar with all button functions.
- Stand on the plastic plate on the treadmill sides, grasp the handrails with both hands, turn on the device at 1.6-3.2 km/h speed. Stand straight and look forward. Try to run on the running belt for a few times with one leg. Then stand onto the running belt to do your exercises. After adapting you can adjust your speed to 3-5 km/h and exercise for about 10 mins. Thereafter stop your exercising slowly.
- Learn to control it properly before first using.
- Walk 1 km. constantly for about 15-25 mins. And record the time. Walk 1 km at a speed of 4.8 km/h (approx. 12 mins). If you are able to do it easily for a few times, you can adjust the speed and incline level and exercise for 30 mins to exercise properly.
- Don't overstretch yourself and exercise reasonably.

## EXERCISE FREQUENCY

The target is 3 – 5 time a week 15 – 60 mins each time. It is better first to elaborate a workout plan and not to exercise only depending on your will. It helps you control your movements and speed or incline adjustment. We recommend not do increase the incline at the initial workout phase.

## WARM-UP PHASE





**NOTE:** The best way to save your time is to do exercises for 15 – 20 mins.

Warm up for 2 minutes at 4.8 km/h and adjust your speed to 5.3 km/h (5.8 km/h) and continue your workout at these speeds levels for 2 mins. Thereafter you can increase your speed by 0.3 km/h per 2 mins until you will breath quickly but not difficultly. If your breathing gets difficult, decrease your speed by 0.3 km/h. At least reduce the speed for 4 minutes. If you remark, it is difficult for you to intensify your workout by increasing the speed, you can try to increase the incline slowly.

**HEAT CONSUMPTION** – It is the real heat consumption. Warm up for 5 minutes at the speed of 4 – 4.8 km/h and then add 0.3 km/h by 2 minutes (speed increasing). You can exercise for 45 mins at this speed level as a challenge to do your workout more strenuous. You can exercise for 1 hour at this speed while watching a TV program and increase your speed by 0.3 km/h by business advertisements. Then return to the previous speed level when next program starts. The heat consumption will be more intensive (increased pulse) during the advertisement time. Keep 4 minutes to reduce your speed.

**NOTE:** Wear suitable sports shoes with clean soles. Wear suitable sports clothes.

**PROMPT WARMING -UP:** It is better to do some warm-up exercises before starting any workout. Stretch your muscles (5-10 mins) to warm up them. Then do warm up workout according to pictures below. Repeat it five times and 10 seconds for each foot. Repeat these exercises after completing your workout.

	<p><b>Reach Down</b></p> <p>Have your knees slightly bent and bend your body slightly forward. Relax your back and shoulders and try to touch your toes. Keep it for 10-15 seconds and relax. Repeat 3 times.</p>
	<p><b>Hamstring Stretching</b></p> <p>Sit on a clean cushion and straight one leg. Put your second leg inwards closely to the inner side of the straight leg. Try to touch your toes by hand. Keep it for 10-15 seconds and relax. Repeat 3 times for each leg.</p>
	<p><b>Tendon Stretching</b></p> <p>Lean by both hands on a wall or tree. Have one leg behind. Keep your legs straight and have your heels on ground. Tilt to the wall or tree. Keep it for 10-15 seconds and relax. Repeat 3 times for each leg.</p>
	<p><b>Quadriceps</b></p> <p>Put your left hand onto a wall or grasp a table and stretch your right hand backwards. Push your right heel to your buttock. Do it slowly until you feel some tension in your front thigh. Keep it for 10-15 seconds and relax. Repeat 3 times for each leg.</p>
	<p><b>Sartorius (Inner Thigh Muscle)</b></p> <p>Sit down with soles in a opposite position. Knees are oriented outwards. Pull your feet towards groin for 10-15 seconds. Relax and repeat 3 times.</p>

# EXPLODED DRAWING

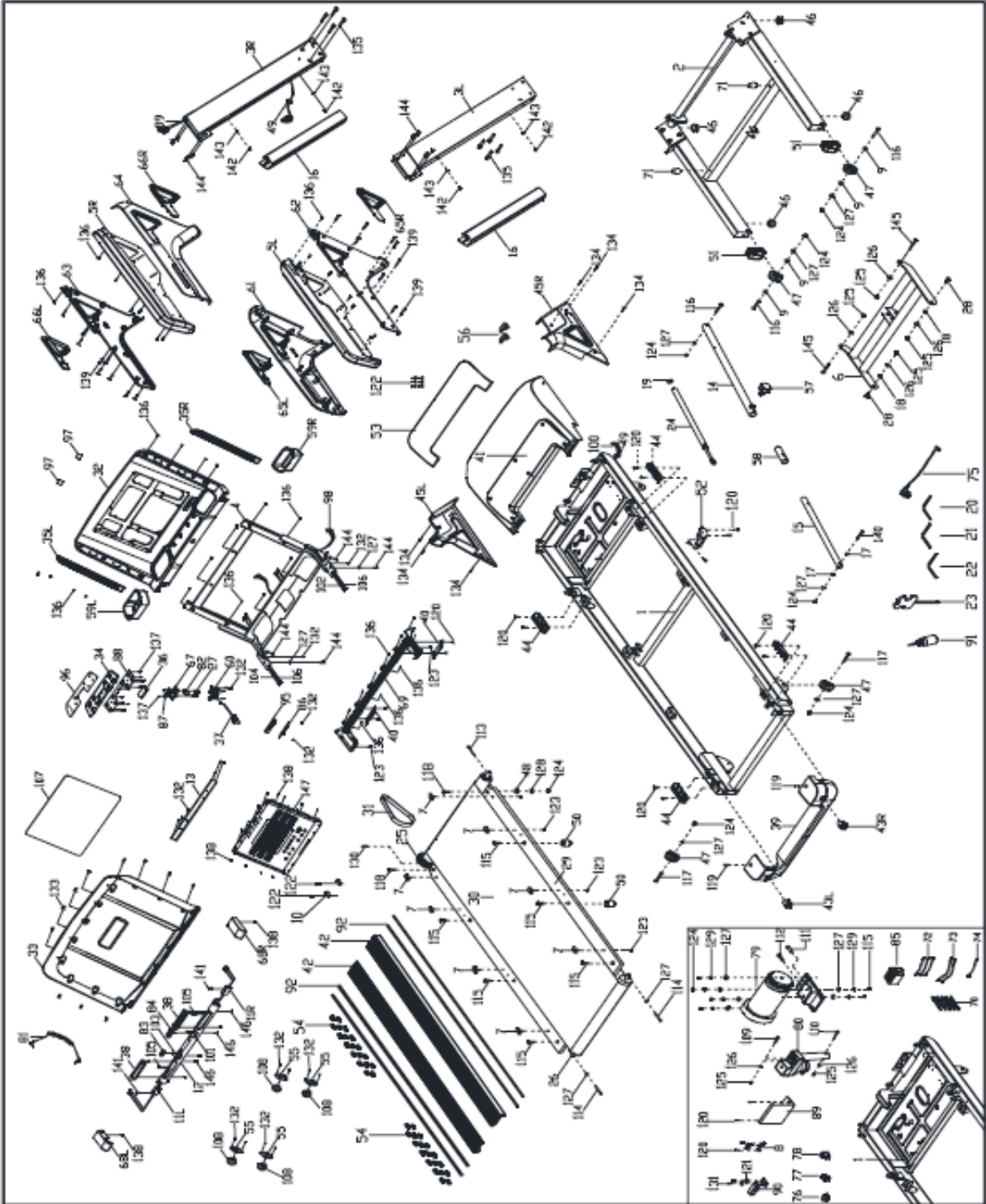

## PARTS LIST

No.	Item	Description	Qty.
1	Main frame		1
2	Base frame		1
3L/R	Upright		2
4	Computer bracket		1
5L/R	Foam handrail		2
6	Incline bracket		1
7	Edging buckle		8
8	Earth wire connector		1
9	Space tube		4
10	Side rail baffle		2
11L/R	Handrail connecting tube	L/R	2
12	Handrail elbow		1
13	PC board bracket base		1
14	Elastic outer tube		1
15	Elastic inner tube		1
16	Upright decorative bar		2
17	Cylinder space tube	∅15*7.7	2
18	Tube	∅18* ∅10*1*9.5	2
19	Cylinder connecting sheet		1
20	Wrench	4#	1
21	Wrench	6#	1
22	Wrench	8#	1
23	Wrench		1
24	Cylinder		1
25	Front roller		1
26	Rear roller		1
27	Compress spring		2
28	Bolt	∅12*7*M10*20	2
29	Running board		1
30	Running belt		1
31	Multi-groove belt		1
32	Meter upper cover		1
33	Meter under cover		1
34	Keyboard		1
35L/R	Loudspeaker fixed seat		2

36	Safety switch		1
37	Safety lock		1
38	Hand pulse components		2
39	Rear cover		1
40	Wire cover board		2
41	Upper motor cover		1
42	Plastic side rail		2
43L/R	Rear decorative cover	L/R	2
44	Oval cushion		4
45L/R	L/R upright cover		2
46	Flat foot pad		4
47	Moving wheel		4
48	Running board shock pad		2
49	Ring wire plug		3
50	Cushion		4
51	Moving wheel compartment		2
52	Belt protective cover		1
53	Decorative motor cap		1
54	Oval anti-slip mat		38
55	Loudspeaker fixed seat		4
56	Side rail setting block		2
57	Spherical pin		1
58	Elastic tube		1
59L/R	Storage box		2
60	Safety switch socket		1
61	Left handrail side cover L		1
62	Left handrail side cover R		1
63	Right handrail side cover L		1
64	Right handrail side cover R		1
65L/R	Left triangle decorative sheet		2
66L/R	Triangle decorative sheet right		2
67	Safety switch board		1
68L/R	Pulse tube small cover left right		2
69	Pulse tube under cover		1
70	Cable tie		5
71	Cushion		2
72	Single wire	150 mm	3
73	Single wire	300 mm	2

74	Single earthen wire		1
75	Power wire		1
76	End socket		1
77	Power switch		1
78	Over-load protection		1
79	DC motor		1
80	Incline motor		1
81	Spring line		1
82	Micro switch		1
83	Incline shortcut key		1
84	Speed shortcut key		1
85	Filter		1
86	USB-PC board		1
87	Emergency button PC board		1
88	Keyboard PC board		1
89	Controller		1
90	Optical electronic sensor		1
91	Silicone oil		1
92	Small side rail		4
93	Main frame assembly		1
94	Computer assembly		1
95	USB sticker		1
96	Keyboard sticker		1
97	Loudspeaker sticker		2
98	Power cord upper wire		1
99	Power cord middle wire		1
100	Lower power wire		1
101	Speed shortcut key upper wire		1
102	Speed shortcut key lower wire		1
103	Incline shortcut key upper wire		1
104	Incline shortcut key lower wire		1
105	Handrail tube hand pulse wire		2
106	Pulse connecting wire		2
107	Panel sticker		1
108	Loudspeaker		4
109	Bolt	M10*45	1
110	Bolt	M10*60	1
111	Bolt	M8*60	1



112	Bolt	M8*55	1
113	Screw	M8*60	1
114	Screw	M8*75	2
115	Screw	M8*20	8
116	Screw	M8*50	3
117	Screw	M8*40	2
118	Screw	M8*30	2
119	Screw	M6*20	2
120	Screw	M4*8	32
121	Flat washer	ø3.2*ø7*t 0.5	2
122	Screw	ST4.0*15	8
123	Nut	M5	8
124	Nut	M8	12
125	Nut	M10	6
126	Washer	ø11*ø22*t 2.0	6
127	Flat washer	ø9*ø16*t1.6	14
128	Washer	ø9*ø23*t1.6	2
129	Spring washer	ø8.1*ø12.3*t2.1	6
130	Screw	M6*20	1
131	Screw	ST3.0*8	2
132	Screw	ST3.0*10	14
133	Screw	M6*15	11
134	Screw	M5*20	6
135	Screw	M10*45	8
136	Screw	BT4.0*15	48
137	Screw	M2.5*8	15
138	Screw	ST3.0*15	16
139	Screw	M6*35	18
140	Screw	M8*45	1
141	Screw	M8*10	2
142	Screw	M6*10	4
143	Flat washer	ø6.6*ø16*t1.6	4
144	Screw	M8*15	12
145	Screw	M10*30	4
146	Screw	ST4.0*15	6
147	Meter		1

## ENVIRONMENT PROTECTION

After the product lifespan expired or if the possible repairing is uneconomic, dispose it according to the local laws and environmentally friendly in the nearest scrapyard.

By proper disposal you will protect the environment and natural sources. Moreover, you can help protect human health. If you are not sure in correct disposing, ask local authorities to avoid law violation or sanctions.

Don't put the batteries among house waste but hand them in to the recycling place.

## TERMS AND CONDITIONS OF WARRANTY, WARRANTY CLAIMS

### General Conditions of Warranty and Definition of Terms

All Warranty Conditions stated hereunder determine Warranty Coverage and Warranty Claim Procedure. Conditions of Warranty and Warranty Claims are governed by Act No. 89/2012 Coll. Civil Code, and Act No. 634/1992 Coll., Consumer Protection, as amended, also in cases that are not specified by these Warranty rules.

The seller is SEVEN SPORT s.r.o. with its registered office in Borivojova Street 35/878, Prague 13000, Company Registration Number: 26847264, registered in the Trade Register at Regional Court in Prague, Section C, Insert No. 116888.

According to valid legal regulations it depends whether the Buyer is the End Customer or not.

“The Buyer who is the End Customer” or simply the “End Customer” is the legal entity that does not conclude and execute the Contract in order to run or promote his own trade or business activities.

“The Buyer who is not the End Customer” is a Businessman that buys Goods or uses services for the purpose of using the Goods or services for his own business activities. The Buyer conforms to the General Purchase Agreement and business conditions.

These Conditions of Warranty and Warranty Claims are an integral part of every Purchase Agreement made between the Seller and the Buyer. All Warranty Conditions are valid and binding, unless otherwise specified in the Purchase Agreement, in the Amendment to this Contract or in another written agreement.

### Warranty Conditions

#### Warranty Period

The Seller provides the Buyer a 24 months Warranty for Goods Quality, unless otherwise specified in the Certificate of Warranty, Invoice, Bill of Delivery or other documents related to the Goods. The legal warranty period provided to the Consumer is not affected.

By the Warranty for Goods Quality, the Seller guarantees that the delivered Goods shall be, for a certain period of time, suitable for regular or contracted use, and that the Goods shall maintain its regular or contracted features.

#### The Warranty does not cover defects resulting from (if applicable):

- User's fault, i.e. product damage caused by unqualified repair work, improper assembly, insufficient insertion of seat post into frame, insufficient tightening of pedals and cranks
- Improper maintenance
- Mechanical damages
- Regular use (e.g. wearing out of rubber and plastic parts, moving mechanisms, joints etc.)
- Unavoidable event, natural disaster
- Adjustments made by unqualified person
- Improper maintenance, improper placement, damages caused by low or high temperature, water, inappropriate pressure, shocks, intentional changes in design or construction etc.

## **Warranty Claim Procedure**

The Buyer is obliged to check the Goods delivered by the Seller immediately after taking the responsibility for the Goods and its damages, i.e. immediately after its delivery. The Buyer must check the Goods so that he discovers all the defects that can be discovered by such check.

When making a Warranty Claim the Buyer is obliged, on request of the Seller, to prove the purchase and validity of the claim by the Invoice or Bill of Delivery that includes the product's serial number, or eventually by the documents without the serial number. If the Buyer does not prove the validity of the Warranty Claim by these documents, the Seller has the right to reject the Warranty Claim.

If the Buyer gives notice of a defect that is not covered by the Warranty (e.g. in the case that the Warranty Conditions were not fulfilled or in the case of reporting the defect by mistake etc.), the Seller is eligible to require a compensation for all the costs arising from the repair. The cost shall be calculated according to the valid price list of services and transport costs.

If the Seller finds out (by testing) that the product is not damaged, the Warranty Claim is not accepted. The Seller reserves the right to claim a compensation for costs arising from the false Warranty Claim.

In case the Buyer makes a claim about the Goods that is legally covered by the Warranty provided by the Seller, the Seller shall fix the reported defects by means of repair or by the exchange of the damaged part or product for a new one. Based on the agreement of the Buyer, the Seller has the right to exchange the defected Goods for a fully compatible Goods of the same or better technical characteristics. The Seller is entitled to choose the form of the Warranty Claim Procedures described in this paragraph.

The Seller shall settle the Warranty Claim within 30 days after the delivery of the defective Goods, unless a longer period has been agreed upon. The day when the repaired or exchanged Goods is handed over to the Buyer is considered to be the day of the Warranty Claim settlement. When the Seller is not able to settle the Warranty Claim within the agreed period due to the specific nature of the Goods defect, he and the Buyer shall make an agreement about an alternative solution. In case such agreement is not made, the Seller is obliged to provide the Buyer with a financial compensation in the form of a refund.



**SEVEN SPORT s.r.o.**

Registered Office: Borivojova 35/878, 130 00 Praha 3, Czech Republic  
Headquarters: Delnicka 957, 749 01 Vitkov, Czech Republic  
Warranty & Service Centre: Cermenska 486, 749 01 Vitkov, Czech Republic  
CRN: 26847264  
VAT ID: CZ26847264  
Phone: +420 556 300 970  
E-mail: eshop@insportline.cz  
reklamace@insportline.cz  
servis@insportline.cz  
Web: www.insportline.cz

---

**SK**

**INSPORTLINÉ s.r.o.**

Headquarters, Warranty & Service centre: Elektrická 6471, 911 01 Trenčín, Slovakia  
CRN: 36311723  
VAT ID: SK2020177082  
Phone: +421(0)326 526 701  
E-mail: objednavky@insportline.sk  
reklamacie@insportline.sk  
servis@insportline.sk  
Web: www.insportline.sk

Date of Sale:

Stamp and Signature of Seller: