

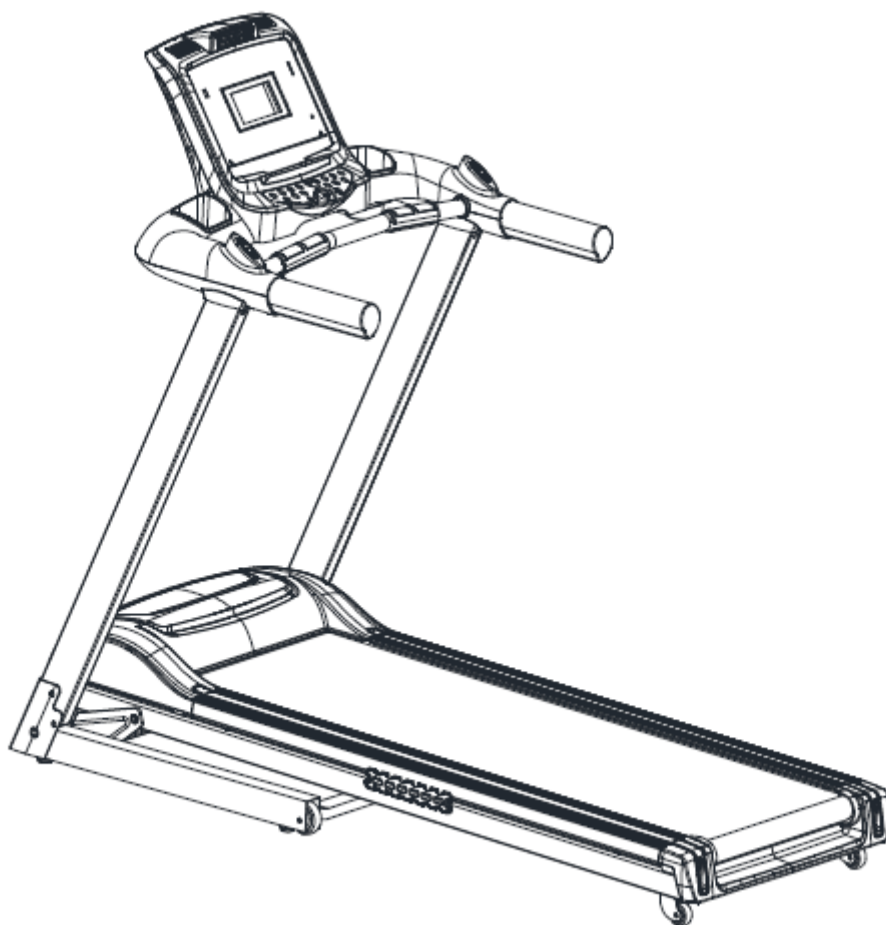

**USER MANUAL – EN**

**IN 13148 Treadmill inSPORTline Akamar**



# CONTENTS

- INTRODUCTION ..... 4
- GENERAL SAFETY INSTRUCTIONS ..... 4
- SPECIAL SAFETY PRECAUTIONS ..... 5
- ASSEMBLY ..... 5
  - Unpacking & Assembly ..... 5
  - Treadmill instruction ..... 7
  - Technical information ..... 7
- ASSEMBLY INSTRUCTIONS ..... 8
- SETTING UP YOUR TREADMILL ..... 10
  - Placement in your home ..... 10
  - Use a dedicated circuit ..... 10
- GETTING STARTED ..... 11
  - Turn the power on ..... 11
  - Safety key and clip ..... 11
  - Getting on and off the treadmill ..... 11
  - Folding the treadmill ..... 11
  - Unfolding the treadmill ..... 11
  - Moving the treadmill ..... 11
- KEY DEFINITION ..... 12
  - Computer function instructions ..... 12
  - LCD window instructions ..... 13
  - Buttons instructions ..... 13
  - Safety key function ..... 14
  - Start instructions ..... 14
  - USER program ..... 15
  - HRC (optional) ..... 15
  - ERP function ..... 16
  - Program speed table ..... 17
- TROUBLE SHOOTING ..... 19
- ERROR MESSAGES AND SOLUTIONS ..... 20
- GENERAL FITNESS TIPS ..... 21
- WARM-UP/STRETCHING EXERCISES ..... 21
  - Neck exercises ..... 21
  - Exercises for the shoulder area ..... 21
  - Arm stretching exercises ..... 22
  - Exercises for the upper thigh ..... 22
  - Inside upper thigh ..... 22

Touch toes .....	22
Exercises for the knees.....	23
Exercises for calf muscles / Achilles tendons .....	23
EXPLODED DRAWING.....	24
PARTS LIST .....	25
TREADMILL MAINTENANCE .....	28
Belt adjustment .....	28
Centering the running belt.....	28
Lubrication.....	29
CLEANING .....	29
STORAGE .....	29
IMPORTANT NOTES .....	29
ENVIRONMENT PROTECTION .....	30
TERMS AND CONDITIONS OF WARRANTY, WARRANTY CLAIMS.....	30

# INTRODUCTION

## Thank You

Thank you for purchasing this product. This product will help you to correctly exercise your muscles and to improve your fitness – and all in familiar environment.

## GENERAL SAFETY INSTRUCTIONS

A great deal of emphasis was placed on safety in the design and manufacture of this fitness device. Still, it is very important that you strictly adhere to the following safety instructions. We cannot be held liable for accidents that were caused by disregarding these instructions. To ensure your safety and to avoid accidents, please read through the operating instructions thoroughly and attentively before you use the machine for the first time.

1. Consult your GP before starting exercising on the device. Should you want to exercise regularly and intensively, the approval of your GP would be advisable. This is especially true for users with health problems.
2. We recommend that handicapped people only use this device when a qualified person is present.
3. When using the fitness device, wear comfortable clothing and preferably sports or aerobic shoes. Avoid wearing loose clothing which could get caught in the moving parts of the device.
4. Stop exercising immediately should you feel unwell or if you feel pain in your joints or muscles. In particular, keep an eye on how is your body responding to the exercise program. Dizziness is a sign that you are exercising too intensively. At the first signs of dizziness, lay down on the ground until you feel better.
5. Ensure there are no children nearby when you are exercising on the treadmill. In addition, the device should be stowed in a place that children or house pets cannot reach.
6. Ensure that only one person at a time uses the fitness device.
7. After the sports device has been set up according to the operating instructions, make sure all screws, bolts and nuts are correctly fitted and tightened. Use only attachments recommended and/or supplied by the importer.
8. Do not use a device that is damaged or unserviceable.
9. Always place the device on a smooth, clean and sturdy surface. Never use near water and make sure there are no pointed objects in the near vicinity of the treadmill. If necessary, place a protective mat /not included in the scope of delivery) to protect the floor underneath the device and for safety reasons keep a free space of at least 0.6 m around the device.
10. Take care not to put your arms and legs near moving parts. Do not place any material in the openings of the device.
11. No adjustable part should be protruding for it could limit the user's range of movement.
12. Use the device only for the purposes described in these operating instructions. Use only attachment s recommended by the manufacturer.
13. If the supply cord is damaged, it must be replaced by the manufacturer, its service agent of similar people in order to avoid hazard.
14. **Category:** HC (EN957 standard) suitable for home use
15. **Weight limit:** 100 kg
16. **WARNING!** The heart rate frequency monitoring may not be completely accurate. Overexertion during training can lead to a serious injury or even death. If you start to feel faint, stop the exercise immediately.

## SPECIAL SAFETY PRECAUTIONS

### Power source

- Choose a place in reach of a socket when placing the treadmill.
- Always connect the appliance to a socket with a grounded circuit and no other appliances connected to it. We do not recommend using extension cords.
- A faulty grounding of the appliance can cause a risk of an electric shock. Ask a qualified electrician to check the socket in case you do not know if the appliance is grounded appropriately. Do not modify the plug provided with the appliance if it is not compatible with your socket. Ask a qualified electrician to install a suitable socket.
- Sudden voltage fluctuations can seriously damage the treadmill. Weather changes or switching on and of other appliances can cause peak voltages, over-voltage or interference voltage. To limit the danger of damage to the treadmill, it should be equipped with an over-voltage protective device (not included).
- Keep power cord away from the carrying roller. Do not leave the power cord below the striding belt. Do not use the treadmill with a damaged or worn out power cord.
- Unplug before cleaning or engaging in maintenance work. Maintenance should only be done by authorized service technicians, unless otherwise stated by the manufacturer. Ignoring these instructions will automatically void the warranty.
- Inspect the treadmill before every use to make sure every part is operational.
- Do not use the treadmill outdoors, in a garage or under any kind of canopy. Do not expose the treadmill to high humidity or direct sunlight.
- Never leave the treadmill unattended.

Make sure the striding belt is always tense. Start the striding belt before stepping on.

**WARNING:** if the power cord is damaged, it must be replaced by the manufacturer, its service agent or similarly qualified person in order to avoid a hazard.

This appliance is not intended for use by people (including children) with reduced physical, sensory or mental capabilities.

Children should be supervised to ensure that they do not play with the appliance.

## ASSEMBLY

- Before attempting to assemble the treadmill, read carefully through the set up steps. We also recommend that prior to the assembly you study the assembly drawing.
- Remove all packaging material and place the individual parts on a free surface. This will provide you with an overview and will simplify assembly.
- Please consider that there is always a risk of injury when using tools and carrying out technical activities. Please proceed with care when assembling the device.
- Make sure you have a hazard-free working environment and do not, for example, leave tools lying around. Deposit the packaging material in such a way that it does not pose a danger. Foil/plastic bags are a potential suffocation risk for children!
- Take your time studying the drawings and then assemble the device according to the series of illustrations.
- The device must be carefully assembled by an adult. If necessary, request aid from another technically proficient person.





### Unpacking & Assembly

**WARNING:** Use extreme caution when assembling the treadmill. Failure to do so could result in injury.



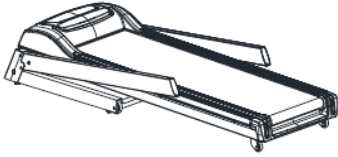
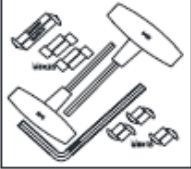

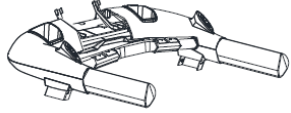

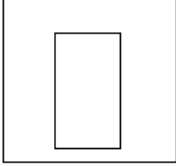

**NOTE:** Each step of the assembly instructions tells you what you will be doing. Read and understand all instructions thoroughly before assembling treadmill.

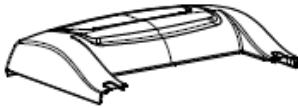
**Unpack and verify the contents of the box**

- Lift up and remove the box that surrounds the treadmill.
- Check if the following items are present. If any of the parts are missing, contact the dealer.

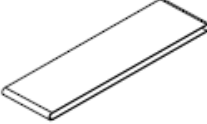

 <p>Main body</p>	 <p>Hardware pack</p>	 <p>Console A</p>	 <p>Console B</p>
 <p>Safety key</p>	 <p>Silicon bottle</p>	 <p>Manual</p>	

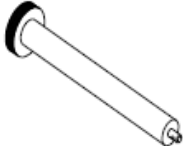
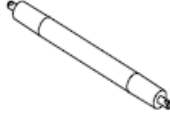
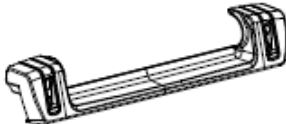
**Main parts**

 <p>Motor cover</p>	 <p>Monitor</p>	 <p>Motor</p>	 <p>Motor belt</p>
 <p>Running belt</p>	 <p>Running deck</p>	 <p>Side rail</p>	 <p>Incline motor</p>
 <p>Front roller</p>	 <p>Rear roller</p>	 <p>Rear cover</p>	

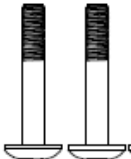
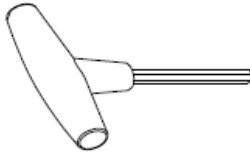
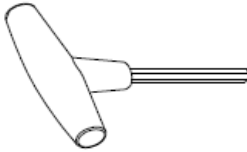
**Hardware bag**

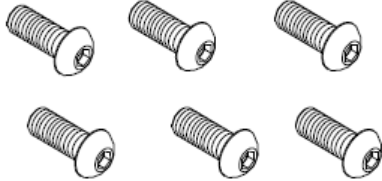
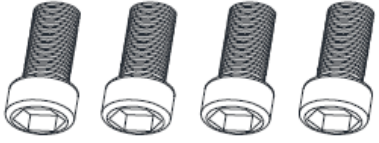
 <p>Allen C.K.S. half thread screw x 2 (M8 x 50 x 20)</p>	 <p>T shaped wrench S6, 1 pc</p>	 <p>T shaped wrench S5, 1 pc</p>
--	---	---

 <p>Allen C.K.S. full thread screw x 6 (M8 x 15)</p>	 <p>Allen socket full thread screw x 4 (M6 x 25)</p>	 <p>L Allen wrench S6, 1 pc</p>
---	--	--

### Treadmill instruction

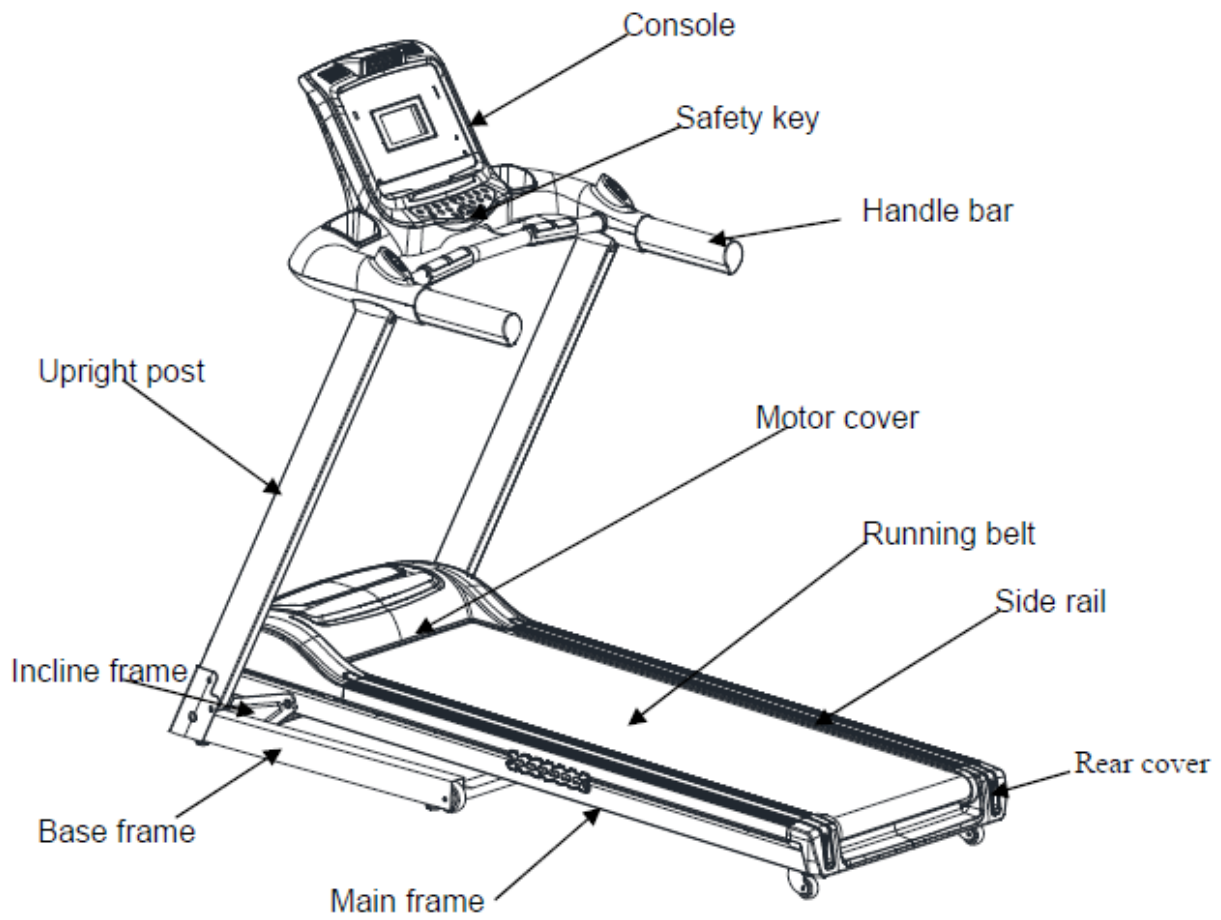

### Technical information

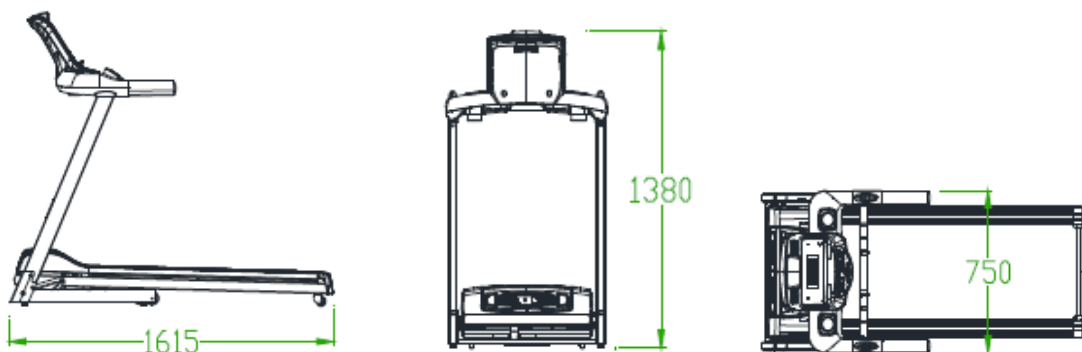

Dimensions	Folded: 1090 x 750 x 1380
	Unfolded: 1615 x 750 x 1380
Effective running surface	1250 x 440
Speed range	1.0 – 16.0 km/h

**We reserve the right to amend the product without prior notice.**

## **ASSEMBLY INSTRUCTIONS**

**Step 1:** Take out the machine from the box and put it on a flat surface (as shown).

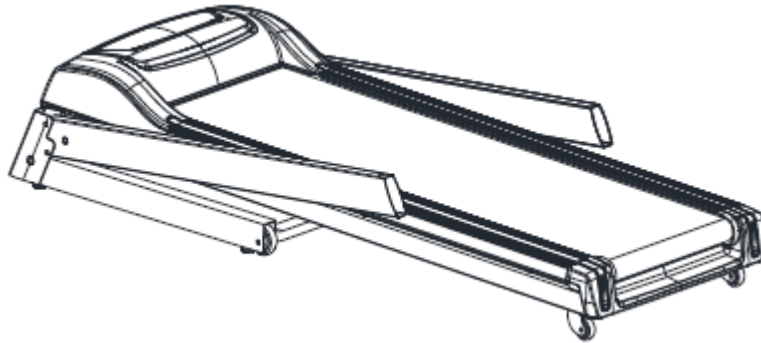

**Step 2:** Insert the upright post into the clamping ring on both sides of the main frame with Allen C.K.S. half head screw M8x50x20 and Allen C.K.S. full thread screw M8x15 (without lock for now).

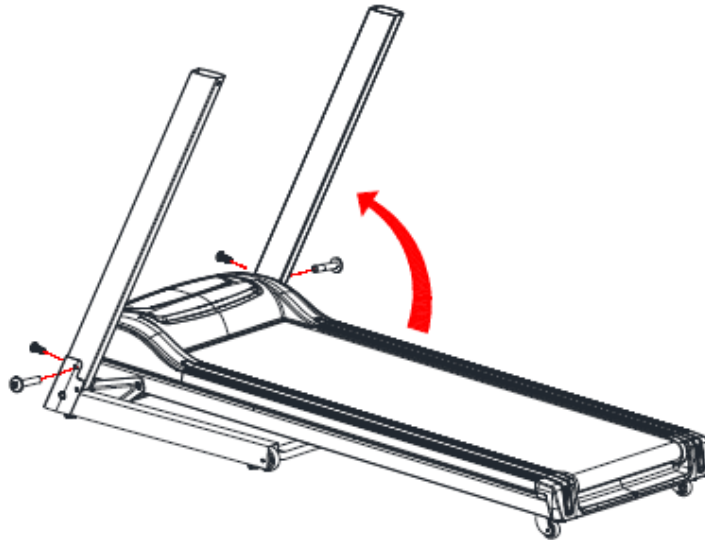



**Step3:** Put the handle bars in a horizontal line (in the direction shown), then connect console B and the upright post with 4 pcs of Allen C.K.S: half head screws M8x15 (lock the bolts).

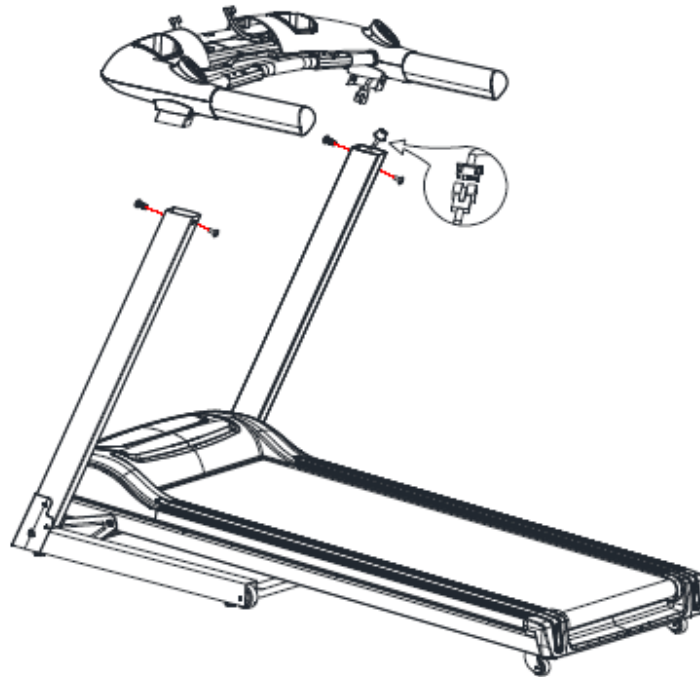

**Step 4:** Put console A on the treadmill and connect the wires well. Use the Allan socket full thread screws M6x25 to tighten the console.

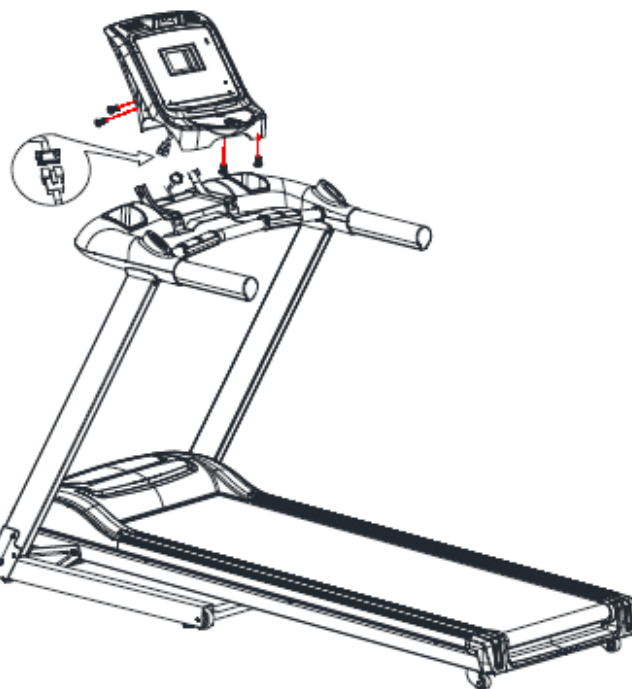

**Step 5:** Fix the screws by tools. Then you're finished.

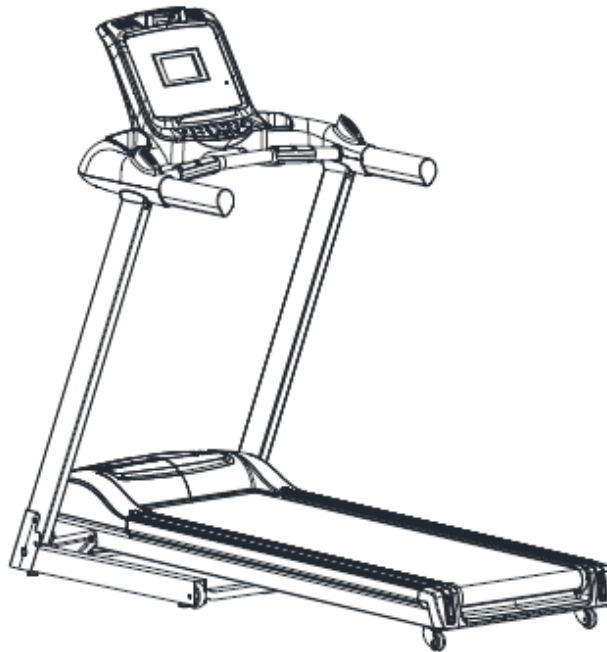

## SETTING UP YOUR TREADMILL

### Placement in your home

To make exercise a desirable activity for you, the treadmill should be placed in a comfortable and convenient setting. This treadmill is designed to use minimal floor space and to fit nicely into your home.

- Do not place the treadmill outdoors.
- Do not place the treadmill near water or in high moisture environment.
- Make sure the power cord is not in the path of heavy traffic.
- If your room is carpeted, check the clearance to make sure there is enough space between the carpet fiber and the treadmill deck. If you are uncertain, it is best to place a mat beneath your treadmill.
- Place the treadmill at least 4 feet from walls or furniture.
- Allow a safety area of at least 0.6 m behind the treadmill so that you can easily get on and off the treadmill without getting trapped during an emergency.

Occasionally, after extended use you will find a fine black dust below your treadmill. This is normal wear and does NOT mean there is anything wrong with your treadmill. This dust can be easily removed with a vacuum cleaner. If you wish to prevent this dust from getting on your floor carpet, place a mat beneath the treadmill.

### Use a dedicated circuit

The selected outlet should be a dedicated circuit. It is particularly important that NO sensitive electrical equipment, such as a computer or TV, share the same circuit.

**CAUTION:** Make sure the running deck is level to the ground. If the deck is positioned on an uneven surface, it will cause premature damage to the electronic system. Read this manual first before operating the treadmill.

## GETTING STARTED

### Turn the power on

Put the power cord into the electrical outlet with 10 A. Flip the switch to the ON position. The screen will turn on with a prompt sound.

### Safety key and clip

The safety key is designed to cut the main power to the treadmill should you fall. Therefore, the safety key is designed to bring the treadmill to immediate stop. At high speeds, this may be uncomfortable and somewhat dangerous. So use the safety key in emergencies only. To bring the treadmill to a complete stop safely and comfortably, use the red stop button.

Your treadmill will not start unless the safety key is properly inserted into the key holder in the middle of the console. The other end of the safety key should be securely clipped to your clothing so that in the case you fall, you will pull the safety key out of the console, which will immediately stop the treadmill and minimize the injury. For your safety, never use the treadmill without securing the safety key to your clothing. Pull on the safety key clip to make sure it will not come off.

### Getting on and off the treadmill

Proceed with care when getting on or off the treadmill. Try to use the handlebars while getting on or off. While you are preparing to use the treadmill, do not stand on the running belt. Place both feet on the side rails. Place your foot on the belt only after the belt has begun to move at a consistent slow speed.

During exercise keep your body and head facing forward at all times. Never attempt to turn around on the treadmill while the running belt is still moving. When you have finished exercising, stop the treadmill by pressing the red stop button. Wait until the treadmill comes to a complete stop before attempting to get off the treadmill.

**WARNING:** Never use the treadmill without first securing the safety clip to your clothing.

**CAUTION:** For your safety, step onto the belt when the speed is no more than 3 km/h.

### Folding the treadmill

1. Restore the incline to flat (0) position.
2. Unplug from power source before folding.
3. Lift deck until it's parallel to the upright post and cylinder locks into position.
4. Caution: Check to ensure cylinder locking device has engaged.

### Unfolding the treadmill

1. Place one hand on the handle bar, then use the other to push the top of the running deck forward.
2. Press one foot on the middle section of the cylinder to disengage the locking mechanism.
3. Allow the deck to begin slowly dropping before releasing your hands.

### Moving the treadmill

The treadmill can be moved around the house safely in its fold-up position by using transport wheel.

Firmly hold onto the handle bars with both hands, pull the treadmill towards you and then drag or push slowly.

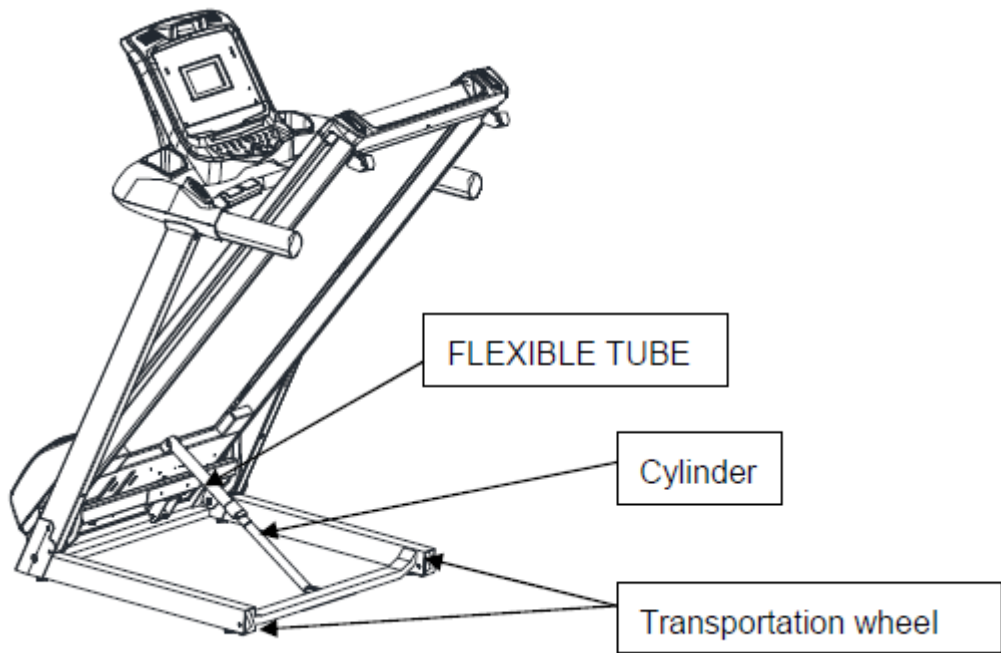

**KEY DEFINITION**

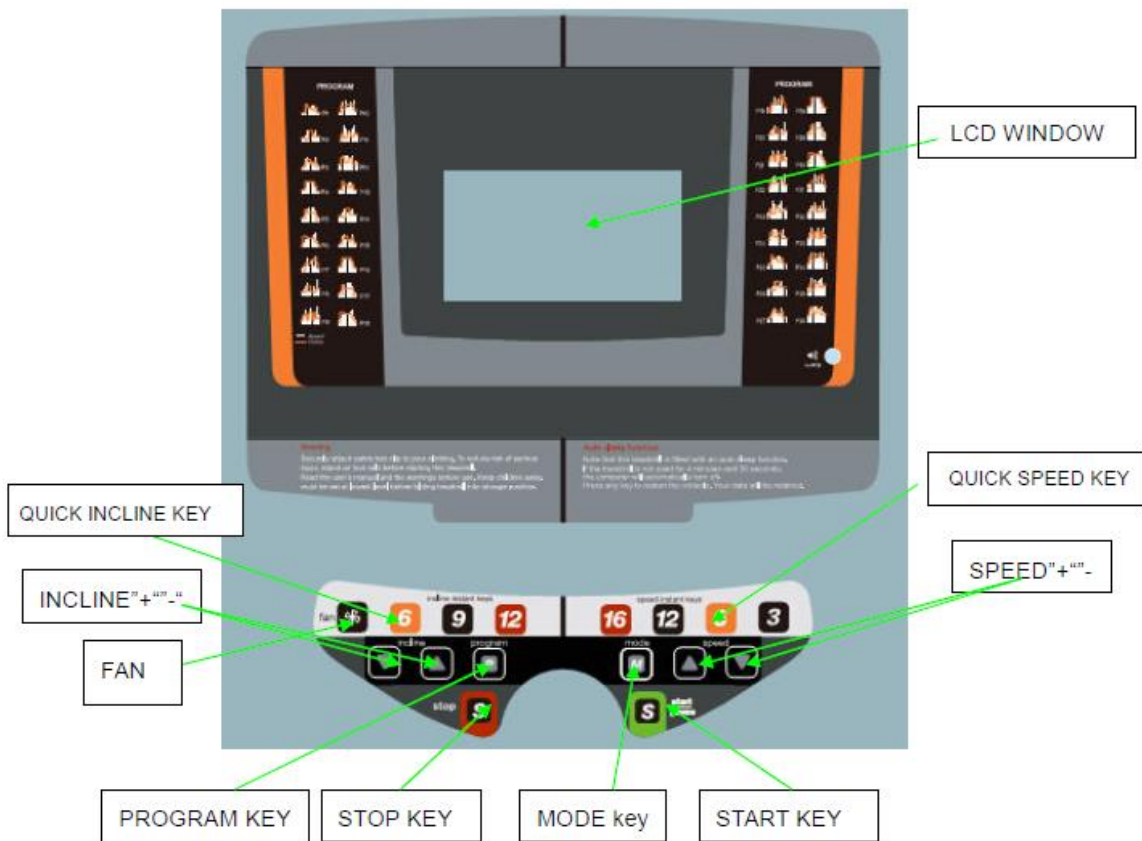

**Computer function instructions**

1. P0: user training program, P1 - P36: preset auto programs, U01 - U03: user-defined programs, FAT: body fat function.

2. 5" LCD display window
3. Speed range: 1.0 – 16.0 km/h
4. Incline range: 0 – 12%
5. Prevents over loading, over voltage, explosion proof, anti-speed and electromagnetic interference.
6. Self-check and warning sound function
7. MP3 (optional)
8. Bluetooth (optional)

## **LCD window instructions**

1. DISTANCE window: Displays the numerical value of distance.
2. CALORIES window: Displays the numerical value of calories.
3. TIME window: Displays the numerical value of time.
4. PULSE window: Displays the numerical value of user's pulse.
5. INCLINE window: Displays the numerical value of incline.

## **The numerical range of each window**

TIME: 0:00 – 99.59 (min)

SPEED: 1.0 – 16.0 (km/h)

INCLINE: 0 – 12%

DISTANCE: 0.00 – 99.9 (km)

CALORIES: 0.0 – 999 (C)

## **Buttons instructions**

1. PROG: Program select key. When the treadmill is stopped, cycle select a program as you prefer, beginning with the manual program and continuing to P1 - P36→U1 - U3→FAT. The pre-set speed of a manual program is 1.0 km/h, maximum speed is 16 km/h.
2. MODE: Mode select key. When the treadmill is stopped, set the mode as you prefer. You can cycle select the time countdown → calories countdown → distance countdown → normal mode.  
  
The reposition of default is 30 minutes when in P1 - P36.  
  
You can't cycle select the FAT item while you are in the FAT mode.
3. START/PAUSE: When the treadmill is stopped, press the START key to turn on the treadmill. If you press START while the treadmill is running, it will pause.
4. STOP: When the treadmill is running, you will slowly stop it by pressing STOP once. If you press STOP twice, the device will stop urgently. When the LCD window shows the ERR message, press the STOP key to erase the message.
5. SPEED+: Will increase the speed while running. Increases the parameters under the FAT mode.
6. SPEED-: Will decrease the speed while running. Decreases the parameters under the FAT mode.
7. QUICK SPEED: When the treadmill is running, speed up directly by pressing the quick speed keys 3, 6, 12, and 16.
8. INCLINE+: Will increase the incline.

9. INCLINE-: Will decrease the incline.
10. QUICK INCLINE: Increases the incline directly by pressing the quick incline keys 6, 9 and 12.

## Safety key function

If the safety key is pulled out at any phase, the display window will show E7 and a buzzer will chime three times. When you put the safety key back in, the display will light for 2 seconds and then go to manual start mode (the equivalent of clearing reset).

## Start instructions

1. Put the power cord into the electrical outlet with 10 A. Flip the switch to the ON position. The screen will light up and a prompt sound will be heard.
2. Put the safety key to the correct position, then turn on the power. The LCD window will light up with a prompt sound. The treadmill will enter the normal mode P0.
3. Press PROG key and cycle select one of the programs (P0 - P36, U01 - U03, FAT).
  - a. P0 is a user program. Use MODE to select one of the four training modes. User can select speed and inclination. Speed default is 1.0 km/h and the inclination default setting is 0%.

Training mode 1: Counting. Counts time, distance and calories during the exercise. The select function is closed.

Training mode 2: Time countdown. While selecting, the time window will flicker. Press + and – to modify the value. The range is 5 – 99 minutes. Default setting is 30:00.

Training mode 3: Distance countdown. While selecting, the distance window will flicker. Press + and – to modify the value. The range is 1.0 – 99 km. The default setting is 1.0 km.

Training mode 4: Calories countdown. While selecting, the calories window will flicker. Press + and – to modify the value. The range is 20 – 990 CAL. The default setting is 50 CAL.
  - b. P1 - P36 are preset programs. They will only work under Time Countdown mode. While selecting, the TIME window will flicker. Press + and - to modify the time. The range is 5 – 99 minutes. The default setting is 30:00. Press MODE to return to defaults.
  - c. FAT is a body fat testing program. Under FAT mode the treadmill has to be stopped.
4. Press START after setting up the training mode. The screen will display 5 second countdown accompanied by chimes. After the countdown is finished, the treadmill will gently start and slowly speed up to the set value. Once the speed is constant the treadmill operates smoothly.
  - a. While running, press +, - or a quick speed button to adjust the speed as you wish.
  - b. For the programs P1 – P36, speed and inclination settings are divided into 10 segments. All the segments last the same amount of time. Manually selected speed will only be available in the current segment. When the current segment ends, you will be reminded by three chimes. When the last segment ends, the motor will stop with a long chime.
  - c. If you press START while running, it will pause the treadmill. If you press START again, the machine will continue where it left off with the recorded data preserved.
5. If you press STOP while running, the treadmill will slowly come to a stop. All settings will return to their default state.
6. Press +, - or quick incline key to adjust the incline you want.
7. If the safety key is pulled out at any phase, the display window will show E7 and a buzzer will chime three times. The treadmill will stop.

8. The controller should always be inspected. If there's anything wrong with it, the treadmill will stop and there will be an error message (ERR) shown on the display window.
9. If the display is showing the ERR message, press STOP and the message will be deleted.
10. Body fat function (optional)

When the treadmill is stopped, press PROG until you select FAT and enter the body fat function. Then press MODE to set the parameters.

- a. F1: Sex – 1(male), 2(female). The default setting is male.
- b. F2: Age – the range is 1 – 99, the default setting is 25.
- c. F3: Height – the range is 100 – 200 cm (39 – 87 inch), the default is 170 cm (67 inch).
- d. F4: Weight – the range is 20 – 150 kg (44 – 330 pounds), the default is 70 kg (154 pounds).
- e. F5: BMI – it will show when you have finished setting the previous items. Put two hands on the handle bar, wait 8 seconds and the window will show your BMI.

BMI under 19 is underweight;

BMI between 19 and 25 is normal weight;

BMI between 26 and 29 is overweight;

BMI over 30 is obesity.

## USER program

The treadmill has three user modes: USER01, USER02 and USER03. They can be adjusted by the user themselves.

Press PROG and cycle select the program U01 – U03. Press MODE and set the parameters. User can set their own exclusive 10 segments of speed and inclination. After setting the parameters, press START and start the treadmill. The user program will be automatically saved and can be used next time.

## HRC (optional)

1. Definition: HRC is a speed mode which can set the heart rate and adjust the speed automatically according to the user's heart rate (either wireless heart rate or heart rate recorded and transferred into the machine).
2. The default HRC is in three groups: HRC1 with speed limit 9 km/h, HRC2 with speed limit 11 km/h and HRC3 with speed limit 13 km/h.
3. HRC can set the range of methods, orders and parameters. When you press the PROG button to display the HRC, press mode to confirm and go to the next setting group. After you press the speed button and set the final parameters, you can start the program.
  - A) Age range: 15 – 80 years old, the default setting is 25 years old.
  - B) Target heart rate:  $(220 - \text{age}) * 0.6$ .
  - C) The correction range of the target heart rate: 80 – 180 bpm.
  - D) The default time setting is 30 minutes. The correction range is 5 – 99 minutes.
4. Speed change
  - A) Changing frequency: HRC will check the heart rate once every 30 seconds and change it accordingly on screen.
  - B) When the user's heart rate is lower than the target heart rate of 360 bpm, the speed will increase by 2.0 km/h.
  - C) When the user's heart rate is lower than the target heart rate of 6 – 29 bpm, the speed will increase by 1.0 km/h.

- D) When the user's heart rate is higher than the target heart rate of 30 bpm, the speed will decrease by 2.0 km/h.
  - E) When the user's heart rate is higher than the target heart rate of 6 – 29 bpm, the speed will decrease by 1.0 km/h.
  - F) If the user's heart rate is higher or lower than the target heart rate of 0 – 5 bpm, the speed won't change.
5. The treadmill will slow down to the lowest speed in 20 seconds and then after 15 seconds stops running if:
    - A) The system can't detect heart rate for one minute.
    - B) The heart rate increases at the lowest speed.
    - C) The heart rate is higher than the value of (220 - age).
  6. You cannot decrease the speed under the speed minimum of 1.0 km/h. For example, if you decrease speed from 1.6 km/h, it will fall to 1.0 km/h, even though the adjustment per one press of the button is 1.0 km/h.
  7. The inclination isn't controlled by the heart rate. It can be adjusted manually.
  8. The initial speed will be 1.0 km/h. It cannot adjust itself according to your heart rate until one minute of running.

## **ERP function**

If the treadmill is turned on, but no operations are running, it will automatically enter a "Sleep mode" after 4 minutes and 30 seconds to save energy.

While in the standby mode, press MODE for 3 seconds and the display will show "2222" to cancel the ERP function. Press MODE again for 3 seconds and the machine will display "1111" to enter the ERP mode.



## Program speed table

PROG	CLS.	SEG.										
			1	2	3	4	5	6	7	8	9	10
P1	SPEED		1.0	3.0	5.0	5.0	5.0	7.0	7.0	5.0	3.0	2.0
	INCLINE		2	2	8	6	6	4	4	6	2	2
P2	SPEED		2.0	3.0	5.0	8.0	5.0	5.0	6.0	8.0	4.0	3.0
	INCLINE		3	3	2	2	8	8	4	4	4	4
P3	SPEED		2.0	3.0	7.0	8.0	5.0	5.0	5.0	8.0	4.0	3.0
	INCLINE		1	2	5	7	7	4	4	6	2	2
P4	SPEED		2.0	2.0	5.0	8.0	8.0	8.0	8.0	5.0	3.0	2.0
	INCLINE		3	3	9	9	9	9	9	6	2	2
P5	SPEED		3.0	4.0	8.0	9.0	10.0	10.0	10.0	7.0	4.0	3.0
	INCLINE		2	2	8	6	6	6	6	6	1	1
P6	SPEED		3.0	4.0	6.0	7.0	7.0	7.0	9.0	10.0	5.0	3.0
	INCLINE		1	8	8	7	7	7	7	5	3	1
P7	SPEED		3.0	4.0	4.0	10.0	4.0	9.0	4.0	11.0	3.0	2.0
	INCLINE		1	1	6	6	6	8	8	10	6	2
P8	SPEED		3.0	5.0	7.0	9.0	3.0	5.0	7.0	5.0	11.0	5.0
	INCLINE		3	3	3	7	7	3	3	3	5	5
P9	SPEED		3.0	7.0	10.0	4.0	7.0	11.0	5.0	4.0	12.0	6.0
	INCLINE		3	6	7	3	8	8	3	8	4	4
P10	SPEED		3.0	5.0	9.0	10.0	6.0	6.0	9.0	6.0	11.0	3.0
	INCLINE		2	7	5	5	8	8	8	8	4	4
P11	SPEED		4.0	5.0	11.0	9.0	6.0	8.0	9.0	11.0	6.0	5.0
	INCLINE		1	6	3	3	7	7	4	4	6	6
P12	SPEED		4.0	6.0	10.0	10.0	10.0	7.0	7.0	10.0	6.0	5.0
	INCLINE		3	8	9	5	5	8	8	4	4	4
P13	SPEED		2.0	4.0	6.0	6.0	6.0	8.0	8.0	6.0	4.0	3.0
	INCLINE		3	3	9	7	7	5	5	7	3	3
P14	SPEED		3.0	4.0	6.0	9.0	6.0	6.0	7.0	9.0	5.0	4.0
	INCLINE		4	4	3	3	9	9	5	5	5	5

P15	SPEED	3.0	4.0	8.0	9.0	6.0	6.0	6.0	9.0	5.0	4.0
	INCLINE	2	3	6	8	8	5	5	7	3	3
P16	SPEED	3.0	3.0	6.0	9.0	9.0	9.0	9.0	6.0	4.0	3.0
	INCLINE	4	4	10	10	10	10	10	7	3	3
P17	SPEED	4.0	5.0	9.0	10.0	11.0	11.0	11.0	8.0	5.0	4.0
	INCLINE	3	3	9	7	7	7	7	7	2	2
P18	SPEED	4.0	5.0	7.0	8.0	8.0	8.0	10.0	11.0	6.0	4.0
	INCLINE	2	9	9	8	8	8	8	6	4	2
P19	SPEED	4.0	5.0	5.0	11.0	5.0	10.0	5.0	12.0	4.0	3.0
	INCLINE	2.0	2	7	7	7	9	9	11	7	3
P20	SPEED	4.0	6.0	8.0	10.0	4.0	6.0	8.0	6.0	12.0	6.0
	INCLINE	4	4	4	8	8	4	4	4	6	6
P21	SPEED	4.0	8.0	11.0	5.0	8.0	12.0	6.0	5.0	12.0	7.0
	INCLINE	4	7	8	4	9	9	4	9	5	5
P22	SPEED	4.0	6.0	10.0	11.0	7.0	7.0	10.0	7.0	12.0	4.0
	INCLINE	3	8	6	6	9	9	9	9	5	5
P23	SPEED	5.0	6.0	12.0	10.0	7.0	9.0	10.0	12.0	7.0	6.0
	INCLINE	2	7	4	4	8	8	5	5	7	7
P24	SPEED	5.0	7.0	11.0	11.0	11.0	8.0	8.0	11.0	7.0	6.0
	INCLINE	4	9	10	6	6	9	9	5	5	5
P25	SPEED	3.0	5.0	7.0	7.0	7.0	9.0	9.0	7.0	5.0	4.0
	INCLINE	4	4	10	8	8	6	6	8	4	4
P26	SPEED	4.0	5.0	7.0	10.0	7.0	7.0	8.0	10.0	6.0	5.0
	INCLINE	5	5	4	4	10	10	6	6	6	6
P27	SPEED	4.0	5.0	9.0	10.0	7.0	7.0	7.0	10.0	6.0	5.0
	INCLINE	3	4	7	9	9	6	6	8	4	4
P28	SPEED	4.0	4.0	7.0	10.0	10.0	10.0	10.0	7.0	5.0	4.0
	INCLINE	5	5	11	11	11	11	11	8	4	4
P29	SPEED	5.0	6.0	10.0	11.0	12.0	12.0	12.0	9.0	6.0	5.0
	INCLINE	4	4	10	8	8	8	8	8	3	3
P30	SPEED	5.0	6.0	8.0	9.0	9.0	9.0	11.0	12.0	7.0	5.0

	INCLINE	3	10	10	9	9	9	9	7	5	3
P31	SPEED	5.0	6.0	6.0	12.0	6.0	11.0	6.0	12.0	5.0	4.0
	INCLINE	3	3	8	8	8	10	10	12	8	4
P32	SPEED	5.0	7.0	9.0	11.0	5.0	7.0	9.0	7.0	12.0	7.0
	INCLINE	5	5	5	9	9	5	5	5	7	7
P33	SPEED	5.0	9.0	12.0	6.0	9.0	12.0	7.0	6.0	12.0	8.0
	INCLINE	5	8	9	5	10	10	5	10	6	6
P34	SPEED	5.0	7.0	11.0	12.0	8.0	8.0	11.0	8.0	12.0	5.0
	INCLINE	4	9	7	7	10	10	10	10	6	6
P35	SPEED	6.0	7.0	12.0	11.0	8.0	10.0	11.0	12.0	8.0	7.0
	INCLINE	3	8	5	5	9	9	6	6	8	8
P36	SPEED	6.0	8.0	12.0	12.0	12.0	9.0	9.0	12.0	8.0	7.0
	INCLINE	5	10	11	7	7	10	10	6	6	6

## TROUBLE SHOOTING

Problem	Possible cause	Corrective action
Treadmill does not work	a. No connection to the power supply	Plug into socket
	b. Safety key not inserted	Insert safety key properly into the monitor
	c. The signal circuit system is cut off	Check the control panel and the signal cable
	d. Treadmill is not switched on	Switch on
	e. Fuse is broken	Replace the fuse
	f. Safety key is not inserted well	Put the safety key in the correct position
	g. Transformer is not well connected or defective	Connect the transformer or replace it
	h. Electric circuit is interrupted	Check the connection wire its terminal and properly connect them
Belt does not run properly	a. Running belt isn't lubricated enough	Lubricate with silicon
	b. Belt is too tight	Adjust running belt
Belt is slipping	a. Belt is too loose	Adjust running belt
	b. Motor belt is too loose	Adjust the motor belt

## ERROR MESSAGES AND SOLUTIONS

Problem	Possible cause	Solution
Treadmill stop suddenly	a. Safety key fell off	Properly insert the safety key
	b. Problem with the electric system	Ask for the after sale service
Key defected	a. Key is damaged	Replace the key
	b. Key cannot work	Replace the key board and the wire. Replace the PCB board. Replace the computer.
E01	a. Connect wire is loose or defective	Properly connect the wire or replace it
	b. Computer is defective	Replace the computer
	c. Transformer is defective	Replace the transformer
	d. Controller is defective	Replace the controller
E02	a. Motor connection wire or the motor itself is defective	Replace the motor wire or the motor
	b. The connection wire between the motor and the controller is loose or the controller is defective	Properly connect the wire or replace the controller
E03	a. Speed sensor not properly put	Properly insert the speed sensor
	b. Speed sensor is defective	Replace the speed sensor
	c. The connection wire between the speed sensor and the controller isn't connected properly	Properly connect the wire
	d. Controller is defective	Replace the controller
E05	a. Controller is defective	Replace the controller
	b. Motor is defective	Replace the motor
E07	Computer cannot test the safety key signal	Check if the safety key is properly inserted
No pulse	a. Handle pulse wire is not well connected or is defective	Properly connect the wire or replace it
	b. Console circuitry is defective	Replace the console
Console short of display	a. A screw on the PCB may be loose	Tighten the loose screw
	b. Console is defective	Replace the console

## GENERAL FITNESS TIPS

Start your exercise program slowly, i.e. one exercise unit every 2 days. Increase your exercise sessions week by week. Begin with short periods per exercise and then increase these continually. Start slowly and don't set yourself impossible targets. In addition to these exercises do other forms of exercise, such as jogging, swimming, dancing and/or cycling.

Always warm up thoroughly before exercising. To do so, carry out at least five minutes of stretching or gymnastic exercises to avoid straining or injuring your muscles.

Check your pulse regularly. If you do not have a pulse measuring instrument, ask your GP about how you can measure your heart rate effectively. Determine your personal exercise frequency range to achieve optimal training success. Take into account both your age and your level of fitness.

Make sure you breathe regularly and calmly while exercising.

Make sure you drink enough during exercising and that your body's liquid requirement is satisfied. Consider that the recommended drinking amount of 2 – 3 liters per day is strongly increased by physical strain. The fluid you drink should be at room temperature.

While exercising on the treadmill, always wear light and comfortable clothing as well as sport shoes. Do not wear loose clothing that could tear or get caught in the device.

This treadmill is only for your personal workout.

## WARM-UP/STRETCHING EXERCISES

A successful exercise session begins with warming up and ends with cooling down and relaxing. These warming up exercises prepare your body for the subsequent demands made upon it. The cooling down/relaxation period after the exercise session ensures that you do not experience any muscular problems. In the following text you'll find stretching exercise instructions for warming up and cooling down your body. Please, pay attention to the following points.

### Neck exercises

Tilt your head to the right and feel the tension in your neck. Slowly drop your head down to your chest in a semi-circle and then turn your head to the left. You will feel a comfortable tension in your neck again. You can repeat this exercise alternately several times.

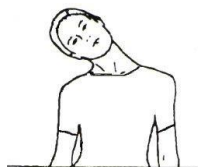

### Exercises for the shoulder area

Lift the left and right shoulder alternately, or lift both shoulders simultaneously.

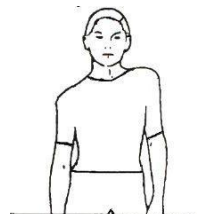

## Arm stretching exercises

Stretch the left and right arms alternately towards the ceiling. Feel the tension in your left and right side. Repeat this exercise several times.

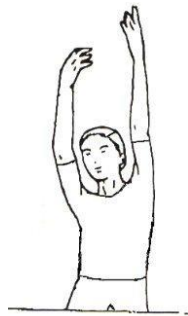

## Exercises for the upper thigh

Support yourself by placing your hand on the wall, then reach down behind you and lift up your right or left foot as close to your buttocks as possible. Feel a comfortable tension in your front upper thigh. Maintain this position for 30 seconds if possible and repeat this exercise 2 times for each leg.



## Inside upper thigh

Sit on the floor and place your feet in such a way that your knees are facing outwards. Pull your feet as close as possible to your groin. Now press your knees carefully downwards. Maintain this position for 30 – 40 seconds if possible.



## Touch toes

Bend your trunk slowly towards and try to touch your feet with your hands. Reach down to your toes as far as possible. Maintain this position for 20 – 30 seconds if possible.

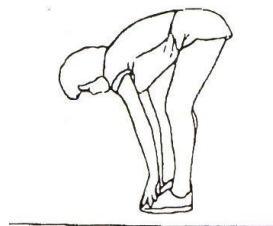

## Exercises for the knees

Sit on the floor and stretch out your right leg. Bend your left leg and place your foot on your upper thigh. Now try to reach your right foot with your right arm. Maintain this position for 30 – 40 seconds if possible.

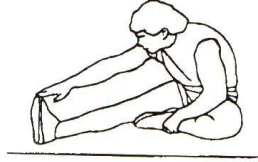

## Exercises for calf muscles / Achilles tendons

Place both hands on the wall and support your full body weight. Then move your left leg backwards and alternate it with your right leg. This stretches the back of the leg. Maintain this position for 30 – 40 seconds if possible.



# EXPLODED DRAWING

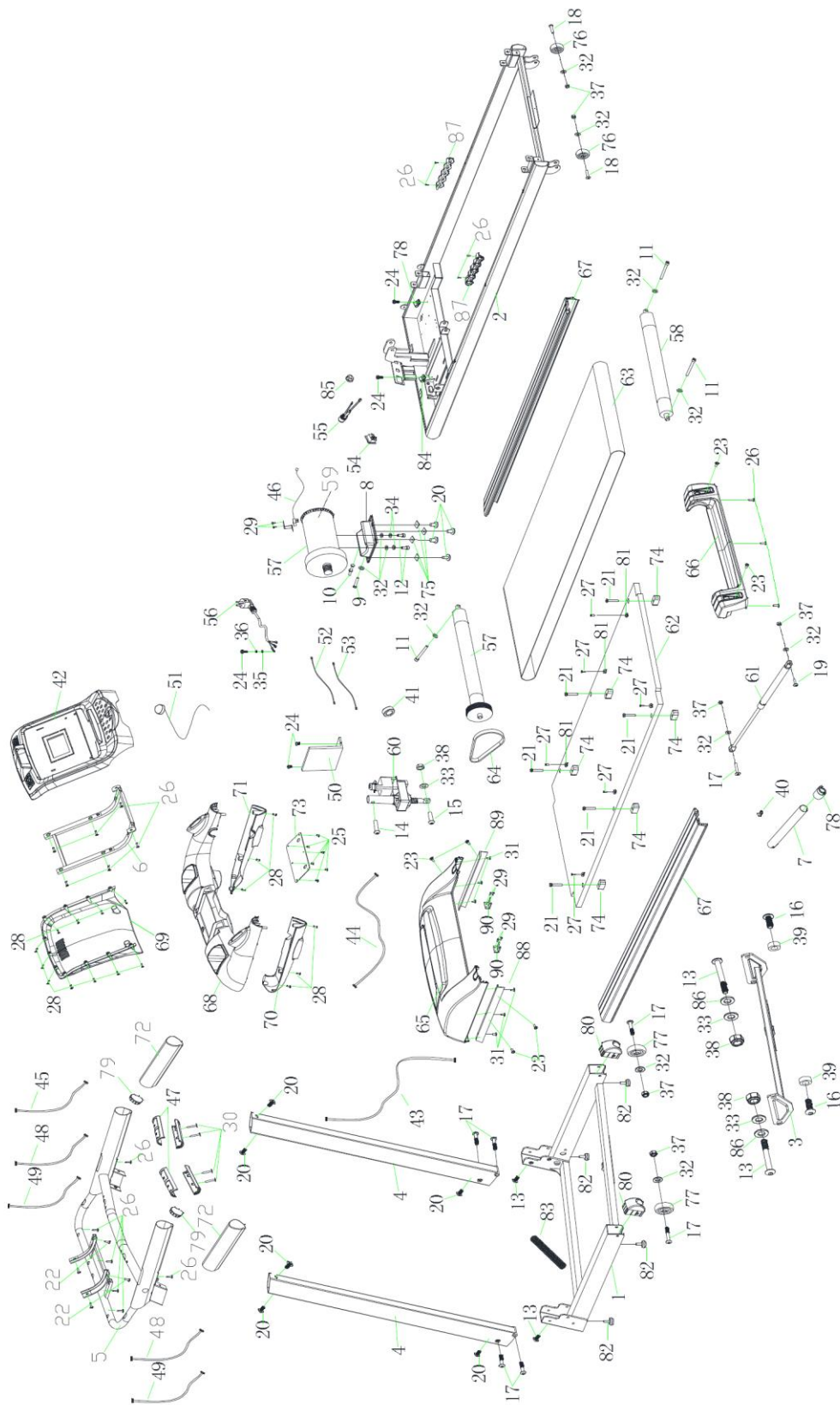



## PARTS LIST

NO	NAME	QUANTITY
1	Base frame	1
2	Platform frame	1
3	Incline frame	1
4	Upright post	2
5	Console frame	1
6	Screen board frame	1
7	Ezfit linking parts	1
8	Motor base frame	1
9	Hex full thread screw M8x75	1
10	Bolt welding M8*65	1
11	Allen socket full thread screw M8x75	3
12	Allen socket full thread screw M8x15	2
13	Allen C.K.S. half thread screw M10*85*20	2
14	Allen C.K.S. half thread screw M10*35*20	1
15	Allen C.K.S. half thread screw M10*60*20	1
16	Allen C.K.S. full thread screw M10x25	2
17	Allen C.K.S. half thread screw M8*50*20	7
18	Allen C.K.S. half thread screw M8*40*20	2
19	Allen C.K.S. half thread screw M8*30*20	1
20	Allen C.K.S. full thread screw M8x15	10
21	Allen countersunk head full thread screw M6x50xΦ16	6
22	Allen socket full thread screw M6x25	4
23	Philips C.K.S: full thread screw M5x10	6
24	Philips C.K.S: full thread screw M4x10	7
25	Philips C.K.S: self-tapping screw ST4x12	6
26	Philips C.K.S: self-tapping screw ST4x16	21
27	Philips countersunk head self-tapping screw ST4x15	6
28	Philips Pan head self-tapping screw ST4x15	17
29	Philips countersunk head self-tapping screw ST3x10	6
30	Philips Pan head self-tapping screw ST3x25	4
31	Philips C.K.S: self-tapping screw ST5,5x15	6
32	Flat washer Φ8	13
33	Flat washer Φ10	3
34	Spring washer Φ8	2
35	Spring washer Φ5	3
36	Lock washer Φ5	3

37	Hex self-locking nut M8	6
38	Hex self-locking nut M10	3
39	Powder metallurgy set $\Phi 17 \times \Phi 10 \times 7$	2
40	Spring	1
41	Magnetic ring	1
42	Console housing	1
43	Communication wire (L-1200 mm)	1
44	Communication wire (L-800 mm)	1
45	Communication wire (L-700 mm)	1
46	Speed sensor L-300	1
47	Handle pulse set	2
48	Handel pulse wire L-800 mm	2
49	Easy handle bar button wire L-800 mm	2
50	Controller	1
51	Safety key	1
52	Power cord	1
53	Power cord	1
54	Switch	1
55	Fuse (with wire)	1
56	Power cord	1
57	Front roller	1
58	Rear roller	1
59	Motor	1
60	Incline motor	1
61	Cylinder	1
62	Running deck	1
63	Running belt	1
64	Motor belt	1
65	Motor cover	1
66	Rear cover	1
67	Side rail	2
68	Console	1
69	Console back cover	1
70	Handel bar cover left	1
71	Handle bar cover right	1
72	Foam grip	2
73	Console bottom cover	1
74	Square cushion	6

75	Square cushion	4
76	Wheel $\Phi 46$	2
77	Wheel $\Phi 62$	2
78	Tube plug	1
79	Droplets pipe plug	2
80	Curved pipe plug	2
81	Side rail guider	6
82	Feet pad	4
83	Wire protector	1
84	Clip	2
85	Power cord buckle	1
86	Plastic flat washer	2
87	Cushion	2
88	Motor cover fixed piece left	1
89	Motor cover fixed piece right	1
90	Motor cover limit piece	2

## TREADMILL MAINTENANCE

Proper maintenance is very important to ensure a faultless and operational condition of the treadmill. Improper maintenance can cause damage to the treadmill or shorten the life of the product.

All parts of the treadmill must be checked and tightened regularly. Worn out parts must be replaced immediately.

### Belt adjustment

You may need to adjust the running belt during the first few weeks of use. All running belts are properly set at the factory. It may stretch and become off center after use. Stretching is normal during the break-in period.

#### Adjusting the belt tension

If the running belt feels as though it is slipping or hesitating when you plant your foot during a run, the tension on the running belt may have to be increased.

1. Place 8mm wrench on the left belt tension bolt. Turn the wrench clockwise by a  $\frac{1}{4}$  turn to draw the rear roller and increase the belt tension.
2. Repeat this step with the right tension bolt. You must be sure to turn both bolts the same number of turns, so the rear roller will stay square relative to the frame.
3. Repeat the two previous steps until the slipping is eliminated.
4. Be careful not to tighten the running belt tension too much as you can create excessive pressure on the front and rear roller bearings. An excessively tightened running belt may damage the roller bearings that would result in bearing noise from the front and rear rollers.

**TO DECREASE THE TENSION OF THE RUNNING BELT, TURN BOTH BOLTS COUNTER-CLOCKWISE THE SAME NUMBER OF TURNS.**

### Centering the running belt

When you run, you may push off harder with one foot than with the other. The severity of the deflection depends on the amount of force that one foot exerts in the relation to the other. This deflection is normal and the running belt will center when nobody is on the running belt. If the running belt remains consistently off-center, you will need to center the running belt manually.

1. Start the treadmill without anyone on the running belt and adjust the speed to 6 km/h.
2. Observe whether the running belt is lopsided towards the right or left side of the deck.
  - If it's lopsided towards the left side of the deck, use a wrench and turn the left adjustment bolt clockwise by a  $\frac{1}{4}$  turn and the right adjustment bolt counter clockwise by the same amount.
  - If it's lopsided towards right side of the deck, turn the right adjustment bolt clockwise by a  $\frac{1}{4}$  turn and the right adjustment bolt counter clockwise by the same amount.
  - If the belt is still not centered, repeat the above step until the running belt is off center.
3. After the belt is centered, increase the speed to 16 km/h and verify that it is running smoothly. Repeat the above steps if necessary.

If the above procedure is unsuccessful in resolving the issue, you may need to increase the belt tension.

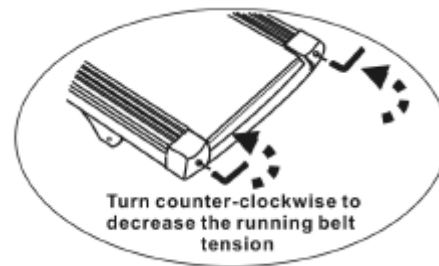
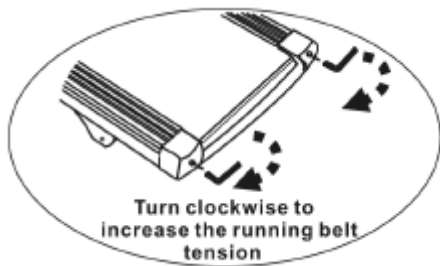

## Lubrication

The treadmill is factory-lubricated. However, it is recommended to check the lubrication of the treadmill regularly, to ensure an optimal operation of the treadmill.

### Frequency:

- During home use lubricate the treadmill 1x per 3 months. During club use check the oil level every week.
- Always use silicon oil inSPORTline

### Application of the lubricant on the belt:

- Position the belt so that the seam is located in the middle of the plate.
- Insert the spray valve in the spray head of the lubricant container.
- Lift the belt at one side and hold the spray valve in a distance to the front end of the striding belt and plate. Start at the front end of the belt. Lead the spray valve in the direction of the back end. Repeat the process on the other side of the belt. Spray each side for about 4 seconds.
- Wait one minute to let the silicon spray spread before starting the machine.

## CLEANING

Regular cleaning of the striding belt ensures a long product life.

**WARNING:** The treadmill must be turned off to avoid electrical shock. Before cleaning or maintenance, the power cord must be pulled out of the socket.

After each training wipe the console and other surfaces with a clean, soft and damp cloth to remove sweat residues.

**CAUTION:** Do not use any abrasives or solvents. To avoid damage to the computer, keep any liquids away. Do not expose the computer to direct sunlight.

To make the cleaning easier it is recommended to use a mat for the treadmill. Shoes can leave dirt on the striding belt that can fall beneath the treadmill. Clean the mat under the treadmill once a week.

## STORAGE

Store your treadmill in a clean and dry environment. Ensure the master power switch is off and is unplugged from the electrical wall outlet.

## IMPORTANT NOTES

- The device corresponds to current safety standards. The device is only suitable for home use. Any other use is impermissible and possibly even dangerous. We cannot be held liable for damages that were caused by improper usage.
- Please consult your GP before starting your exercise session to clarify whether you are in suitable physical health for exercising with this device. The doctor's diagnosis should be the

basis for the structure of your exercise program. Incorrect or excessive training could be harmful to your health.

- Carefully read through the following general fitness tips and the exercise instructions. If you have pain, shortness of breath, feel unwell or have other physical complaints, break off the exercise immediately. Consult a doctor immediately if you have prolonged pain.
- This fitness device is not suitable for professional or medical use, nor may it be used for therapeutic purposes.
- The pulse sensor is not a medical device. It is meant for informational purposes only and is designed to give an average pulse rate. It is not intended to offer medical advice, nor will it measure pulse accurately every time, due to differing environmental and human conditioning factors.

## **ENVIRONMENT PROTECTION**

After the product lifespan expired or if the possible repairing is uneconomic, dispose it according to the local laws and environmentally friendly in the nearest scrapyards.

By proper disposal you will protect the environment and natural sources. Moreover, you can help protect human health. If you are not sure in correct disposing, ask local authorities to avoid law violation or sanctions.

Don't put the batteries among house waste but hand them in to the recycling place.

## **TERMS AND CONDITIONS OF WARRANTY, WARRANTY CLAIMS**

### **General Conditions of Warranty and Definition of Terms**

All Warranty Conditions stated hereunder determine Warranty Coverage and Warranty Claim Procedure. Conditions of Warranty and Warranty Claims are governed by Act No. 89/2012 Coll. Civil Code, and Act No. 634/1992 Coll., Consumer Protection, as amended, also in cases that are not specified by these Warranty rules.

The seller is SEVEN SPORT s.r.o. with its registered office in Borivojova Street 35/878, Prague 13000, Company Registration Number: 26847264, registered in the Trade Register at Regional Court in Prague, Section C, Insert No. 116888.

According to valid legal regulations it depends whether the Buyer is the End Customer or not.

"The Buyer who is the End Customer" or simply the "End Customer" is the legal entity that does not conclude and execute the Contract in order to run or promote his own trade or business activities.

"The Buyer who is not the End Customer" is a Businessman that buys Goods or uses services for the purpose of using the Goods or services for his own business activities. The Buyer conforms to the General Purchase Agreement and business conditions.

These Conditions of Warranty and Warranty Claims are an integral part of every Purchase Agreement made between the Seller and the Buyer. All Warranty Conditions are valid and binding, unless otherwise specified in the Purchase Agreement, in the Amendment to this Contract or in another written agreement.

### **Warranty Conditions**

#### **Warranty Period**

The Seller provides the Buyer a 24 months Warranty for Goods Quality, unless otherwise specified in the Certificate of Warranty, Invoice, Bill of Delivery or other documents related to the Goods. The legal warranty period provided to the Consumer is not affected.

By the Warranty for Goods Quality, the Seller guarantees that the delivered Goods shall be, for a certain period of time, suitable for regular or contracted use, and that the Goods shall maintain its regular or contracted features.

**The Warranty does not cover defects resulting from (if applicable):**

- User's fault, i.e. product damage caused by unqualified repair work, improper assembly, insufficient insertion of seat post into frame, insufficient tightening of pedals and cranks
- Improper maintenance
- Mechanical damages
- Regular use (e.g. wearing out of rubber and plastic parts, moving mechanisms, joints etc.)
- Unavoidable event, natural disaster
- Adjustments made by unqualified person
- Improper maintenance, improper placement, damages caused by low or high temperature, water, inappropriate pressure, shocks, intentional changes in design or construction etc.

### **Warranty Claim Procedure**

The Buyer is obliged to check the Goods delivered by the Seller immediately after taking the responsibility for the Goods and its damages, i.e. immediately after its delivery. The Buyer must check the Goods so that he discovers all the defects that can be discovered by such check.

When making a Warranty Claim the Buyer is obliged, on request of the Seller, to prove the purchase and validity of the claim by the Invoice or Bill of Delivery that includes the product's serial number, or eventually by the documents without the serial number. If the Buyer does not prove the validity of the Warranty Claim by these documents, the Seller has the right to reject the Warranty Claim.

If the Buyer gives notice of a defect that is not covered by the Warranty (e.g. in the case that the Warranty Conditions were not fulfilled or in the case of reporting the defect by mistake etc.), the Seller is eligible to require a compensation for all the costs arising from the repair. The cost shall be calculated according to the valid price list of services and transport costs.

If the Seller finds out (by testing) that the product is not damaged, the Warranty Claim is not accepted. The Seller reserves the right to claim a compensation for costs arising from the false Warranty Claim.

In case the Buyer makes a claim about the Goods that is legally covered by the Warranty provided by the Seller, the Seller shall fix the reported defects by means of repair or by the exchange of the damaged part or product for a new one. Based on the agreement of the Buyer, the Seller has the right to exchange the defected Goods for a fully compatible Goods of the same or better technical characteristics. The Seller is entitled to choose the form of the Warranty Claim Procedures described in this paragraph.

The Seller shall settle the Warranty Claim within 30 days after the delivery of the defective Goods, unless a longer period has been agreed upon. The day when the repaired or exchanged Goods is handed over to the Buyer is considered to be the day of the Warranty Claim settlement. When the Seller is not able to settle the Warranty Claim within the agreed period due to the specific nature of the Goods defect, he and the Buyer shall make an agreement about an alternative solution. In case such agreement is not made, the Seller is obliged to provide the Buyer with a financial compensation in the form of a refund.



**SEVEN SPORT s.r.o.**

Registered Office: Borivojova 35/878, 130 00 Praha 3, Czech Republic  
Headquarters: Delnicka 957, 749 01 Vitkov, Czech Republic  
Warranty & Service Centre: Cermenska 486, 749 01 Vitkov, Czech Republic  
CRN: 26847264  
VAT ID: CZ26847264  
Phone: +420 556 300 970  
E-mail: eshop@insportline.cz  
reklamace@insportline.cz  
servis@insportline.cz  
Web: www.insportline.cz

---

**SK**

**INSPORTLINÉ s.r.o.**

Headquarters, Warranty & Service centre: Elektrická 6471, 911 01 Trenčín, Slovakia  
CRN: 36311723  
VAT ID: SK2020177082  
Phone: +421(0)326 526 701  
E-mail: objednavky@insportline.sk  
reklamacie@insportline.sk  
servis@insportline.sk  
Web: www.insportline.sk

Date of Sale:

Stamp and Signature of Seller: