



USER MANUAL – EN

IN 1227 Multi-Purpose Bench inSPORTline Profi Sit Up Bench



CONTENTS

SAFETY INSTRUCTIONS..... 3
DIAGRAM..... 4
PARTS LIST 5
ASSEMBLY 5
MAINTENANCE 5
EXERCISE INSTRUCTIONS 5
ENVIRONMENT PROTECTION 7
TERMS AND CONDITIONS OF WARRANTY, WARRANTY CLAIMS..... 7

SAFETY INSTRUCTIONS

- Before use and assembly, read the manual and keep the manual for future reference.
- Keep out of reach of children and pets.
- Only for one person at a time.
- If you experience nausea, chest pain or any other abnormal physical symptoms, stop exercising immediately.
- Keep limbs away from moving parts.
- Place the machine on a flat, firm, and clean surface.
- Always wear suitable sports clothing and shoes, do not wear loose clothing or jewelry.
- Use only for the purposes for which the machine was assembled.
- Do not make unauthorized modifications.
- Remove all sharp objects around the device during use.
- For safety keep at least 0.6 m free space around the device.
- People with limited mental or physical abilities must not use the machine.
- Always warm up your muscles before training.
- If sharp edges appear on the machine, stop using the machine immediately.
- Do not put sharp items on the device. Adjustable parts should not interfere with user's movement.
- Inspect the machine before each use; make sure all connections are tightly secured.
- **Maximum weight limit:** 250 kg
- **Category:** S suitable for home, club and hotel gyms
- **WARNING:** Before beginning any exercise program, consult your physician. This is especially important for persons with pre-existing health problems. The seller assumes no responsibility for personal injury or property damage sustained by or through the use of this product.

DIAGRAM

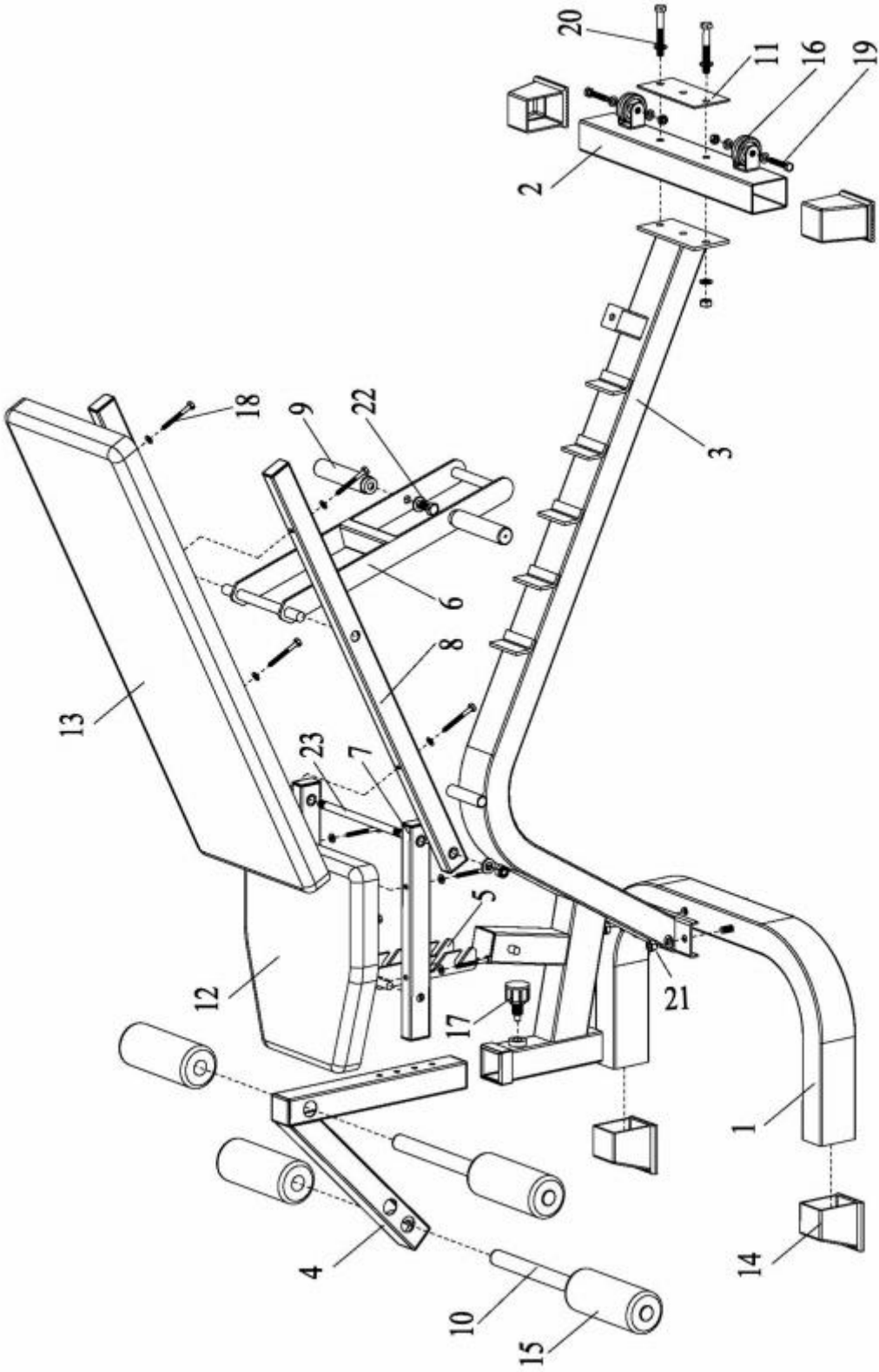

PARTS LIST

No.	Name	Qty.	No.	Name	Qty.
1.	Front stabilizer	1	13.	Backrest	1
2.	Rear stabilizer	1	14.	Plastic end cap	4
3.	Main frame	1	15.	Foam roller	4
4.	Leg rest frame	1	16.	Wheels	2
5.	Seat post	1	17.	Hand knob	1
6.	Adjustable backrest frame	1	18.	Bolt M8x60 + washer	8
7.	Seat holder	2	19.	Bolt M8x45 + 2x washers + nut	2
8.	Backrest holder	2	20.	Bolt M10x75 + 2x washers + nut	2
9.	Grips	2	21.	Washer + nut	2
10.	Foam roller holder	1	22.	Bolt M10x20 + washer	2
11.	Connection plate	1	23.	Bolt M12x212 + 2x washers + 2 nut	1
12.	Seat	1			

ASSEMBLY

1. Insert 4x plastic end caps (14) on the front and rear stabilizers (1 and 2). Then attach 2x wheels (16) to the rear stabilizer (2) using 2x M8x45 screws + 4x washers + 2x nuts (19).
2. Attach the front stabilizer (1) to the main frame (3) with 2x washers + 2x nuts (21).
3. Attach the seat holder (7) to the seat post (5) and then attach the seat (12) to the seat holder (7).
4. Attach the backrest holder (8) to the adjustable backrest frame (6) with 4x M8x60 bolts + 4x washers (18) and then attach the assembled construction to the main frame (3) with M12x212 bolts + 2x washers + 2x nuts (23).
5. Attach backrest (13) to the Adjustable backrest frame (6) with 4x M6x60 bolts + 4x washers (18).
6. Attach the leg rest frame (4) to the main frame (3) and secure with hand knob (17).
7. Insert the foam roller holder (10) into the frame (4) and then attach the foam rollers (15) to the holders.

MAINTENANCE

- Regularly lubricate all moving parts.
- Check and tighten all connections.
- Clean the device with damp cloth and non-aggressive cleaning detergent.
- Regularly check the device for sign of wear or damage.
- Immediately replace worn or damaged parts.

EXERCISE INSTRUCTIONS

Exercise is beneficial to your health, improves physical condition, shapes muscles and, in combination with a calorie-balanced diet, leads to weight loss.

1. WARM UP

This phase serves to improve the blood circulation of the whole body and to warm up the muscles, to reduce the risk of convulsions and muscle injury. We recommend performing the stretching exercises below. When dragging, stay in the end position for approximately 30 seconds, do not make sudden movements and do not vibrate.

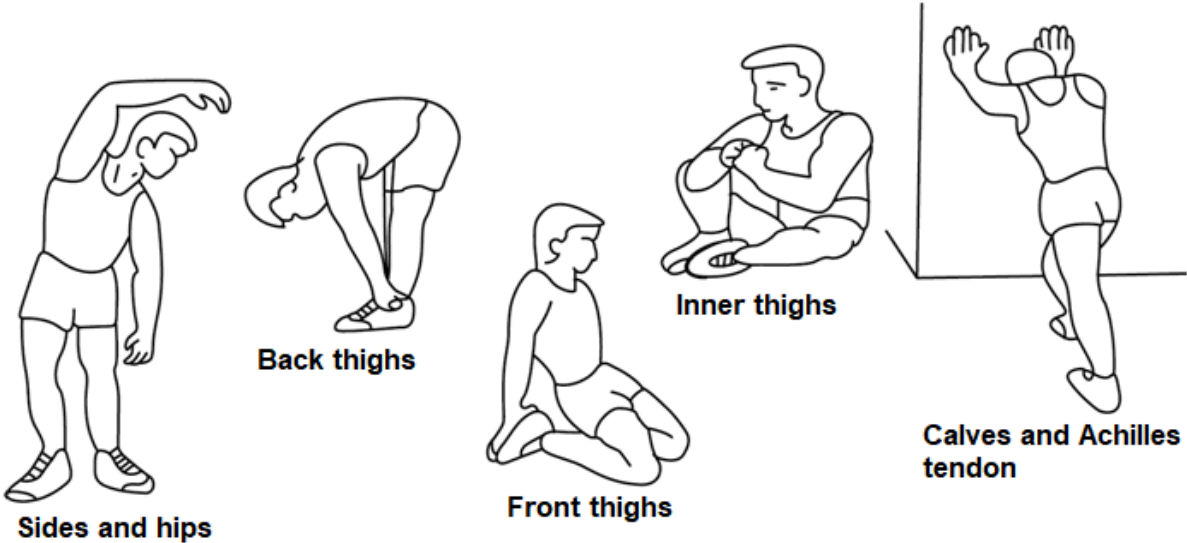

2. EXERCISING

This phase is the most physically demanding part. Regular exercise strengthens the muscles. You can determine the tempo yourself, but it is very important that it is the same throughout the exercise. Heart rate should be within the target zone (see figure below).

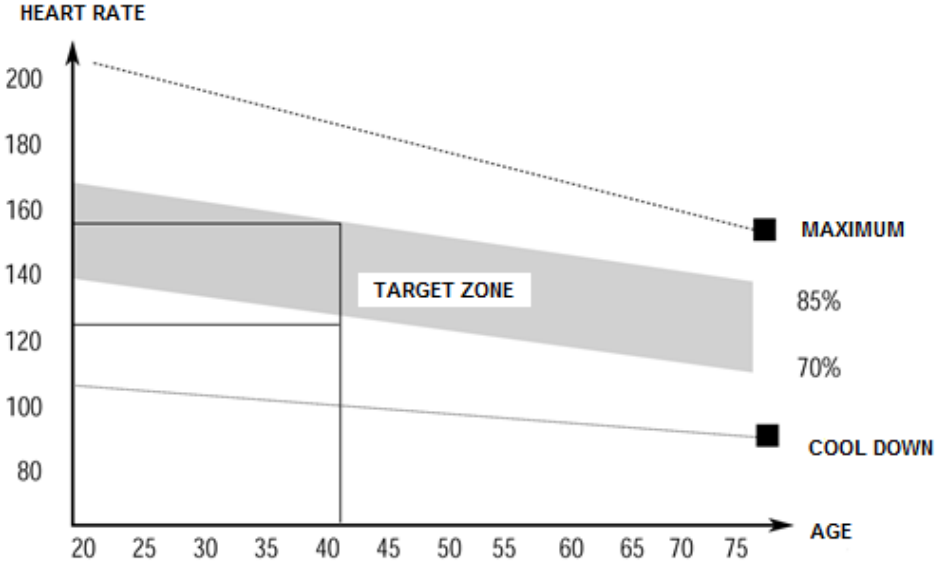

This phase should last at least 12 minutes. Most people exercise for 15-20 minutes.

3. COOLDOWN

This phase serves to soothe the cardiovascular system and relax the muscles. It should take approximately 5 minutes. You can repeat warming up exercises or continue exercising at slower pace. Stretching your muscles after exercise is extremely important - you need to avoid sudden movements and vibrations.

With improved fitness, you can lengthen and increase exercise intensity. Train regularly, at least three times a week.

SHAPING MUSCLES

For muscle shaping, it is important to set a high load. The muscles will be more stressed, which may cause that you will not be able to exercise as long as usual. If you are trying to improve your condition at the same time, you need to adjust your training. Exercise in the usual way during the warm-up and final stages of training but increase the resistance of the device at the end of the exercise. You may need to slow down the speed to keep the heart rate in the target area.

WEIGHT LOSS

The number of calories burned depends on the length and intensity of the exercise. The essence is the same as in fitness exercise, but the goal is different.

ENVIRONMENT PROTECTION

After the product lifespan expired or if the possible repairing is uneconomic, dispose it according to the local laws and environmentally friendly in the nearest scrapyard.

By proper disposal you will protect the environment and natural sources. Moreover, you can help protect human health. If you are not sure in correct disposing, ask local authorities to avoid law violation or sanctions.

Don't put the batteries among house waste but hand them in to the recycling place.

TERMS AND CONDITIONS OF WARRANTY, WARRANTY CLAIMS

General Conditions of Warranty and Definition of Terms

All Warranty Conditions stated here under determine Warranty Coverage and Warranty Claim Procedure. Conditions of Warranty and Warranty Claims are governed by Act No. 89/2012 Coll. Civil Code, and Act No. 634/1992 Coll., Consumer Protection, as amended, also in cases that are not specified by these Warranty rules.

The seller is SEVEN SPORT s.r.o. with its registered office in Strakonická street 1151/2c, Prague 150 00, Company Registration Number: 26847264, registered in the Trade Register at Regional Court in Prague, Section C, Insert No. 116888.

According to valid legal regulations it depends whether the Buyer is the End Customer or not.

“The Buyer who is the End Customer” or simply the “End Customer” is the legal entity that does not conclude and execute the Contract in order to run or promote his own trade or business activities.

“The Buyer who is not the End Customer” is a Businessman that buys Goods or uses services for the purpose of using the Goods or services for his own business activities. The Buyer conforms to the General Purchase Agreement and business conditions.

These Conditions of Warranty and Warranty Claims are an integral part of every Purchase Agreement made between the Seller and the Buyer. All Warranty Conditions are valid and binding, unless otherwise specified in the Purchase Agreement, in the Amendment to this Contract or in another written agreement.

Warranty Conditions

Warranty Period

The Seller provides the Buyer a 24 months Warranty for Goods Quality, unless otherwise specified in the Certificate of Warranty, Invoice, Bill of Delivery or other documents related to the Goods. The legal warranty period provided to the Consumer is not affected.

By the Warranty for Goods Quality, the Seller guarantees that the delivered Goods shall be, for a certain period of time, suitable for regular or contracted use, and that the Goods shall maintain its regular or contracted features.

The Warranty does not cover defects resulting from (if applicable):

- User's fault, i.e. product damage caused by unqualified repair work, improper assembly, insufficient insertion of seat post into frame, insufficient tightening of pedals and cranks

- Improper maintenance
- Mechanical damages
- Regular use (e.g. wearing out of rubber and plastic parts, moving mechanisms, joints, wear of brake pads/blocks, chain, tires, cassette/multi wheel etc.)
- Unavoidable event, natural disaster
- Adjustments made by unqualified person
- Improper maintenance, improper placement, damages caused by low or high temperature, water, inappropriate pressure, shocks, intentional changes in design or construction etc.

Warranty Claim Procedure

The Buyer is obliged to check the Goods delivered by the Seller immediately after taking the responsibility for the Goods and its damages, i.e. immediately after its delivery. The Buyer must check the Goods so that he discovers all the defects that can be discovered by such check.

When making a Warranty Claim the Buyer is obliged, on request of the Seller, to prove the purchase and validity of the claim by the Invoice or Bill of Delivery that includes the product's serial number, or eventually by the documents without the serial number. If the Buyer does not prove the validity of the Warranty Claim by these documents, the Seller has the right to reject the Warranty Claim.

If the Buyer gives notice of a defect that is not covered by the Warranty (e.g. in the case that the Warranty Conditions were not fulfilled or in the case of reporting the defect by mistake etc.), the Seller is eligible to require a compensation for all the costs arising from the repair. The cost shall be calculated according to the valid price list of services and transport costs.

If the Seller finds out (by testing) that the product is not damaged, the Warranty Claim is not accepted. The Seller reserves the right to claim a compensation for costs arising from the false Warranty Claim.

In case the Buyer makes a claim about the Goods that is legally covered by the Warranty provided by the Seller, the Seller shall fix the reported defects by means of repair or by the exchange of the damaged part or product for a new one. Based on the agreement of the Buyer, the Seller has the right to exchange the defected Goods for a fully compatible Goods of the same or better technical characteristics. The Seller is entitled to choose the form of the Warranty Claim Procedures described in this paragraph.

The Seller shall settle the Warranty Claim within 30 days after the delivery of the defective Goods, unless a longer period has been agreed upon. The day when the repaired or exchanged Goods is handed over to the Buyer is considered to be the day of the Warranty Claim settlement. When the Seller is not able to settle the Warranty Claim within the agreed period due to the specific nature of the Goods defect, he and the Buyer shall make an agreement about an alternative solution. In case such agreement is not made, the Seller is obliged to provide the Buyer with a financial compensation in the form of a refund.

CZ SEVEN SPORT s.r.o.

Registered Office: Strakonická 1151/2c, Praha 5, 150 00, ČR
Headquarters: Dělnická 957, Vítkov, 749 01
Warranty & Service: Čermenská 486, Vítkov 749 01

CRN: 26847264
VAT ID: CZ26847264

Phone: +420 556 300 970
E-mail: eshop@insportline.cz
reklamace@insportline.cz
servis@insportline.cz

Web: www.inSPORTline.cz

SK inSPORTline s.r.o.

Headquarters, warranty & service center: Električná 6471, Trenčín 911 01, SK

CRN: 36311723
VAT ID: SK2020177082
Phone: +421(0)326 526 701
E-mail: objednavky@insportline.sk
reklamacie@insportline.sk
servis@insportline.sk
Web: www.inSPORTline.sk